

बिड दस्तावेज़ / Bid Document

बिड विवरण/Bid Details	
बिड बंद होने की तारीख/समय /Bid End Date/Time	28-08-2025 13:00:00
बिड खुलने की तारीख/समय /Bid Opening Date/Time	28-08-2025 13:30:00
बिड पेशकश वैधता (बंद होने की तारीख से)/Bid Offer Validity (From End Date)	120 (Days)
मंत्रालय/राज्य का नाम/Ministry/State Name	Ministry Of Petroleum And Natural Gas
विभाग का नाम/Department Name	Oil India Limited
संगठन का नाम/Organisation Name	Oil India Limited
कार्यालय का नाम/Office Name	Oil India Limited
कुल मात्रा/Total Quantity	6
वस्तु श्रेणी /Item Category	Supply, Installation and Commissioning, Training of Electronic Burner Management System
GeMARPTS में खोजी गई स्ट्रिंग्स / Searched Strings used in GeMARPTS	Electronic Burner Management System
GeMARPTS में खोजा गया परिणाम / Searched Result generated in GeMARPTS	electronic physiogrowth monitoring system, Online UPS (V2), Grievance Management System Software, Video Management System Software, Database Management System Software (V2), Enterprise Management System Software, WEB GIS Based Project Management Software, File And Leave Management System Software, Access Control System, Accounts and Bill Monitoring Management System Software
अधिसूचना के लिए चयनित प्रासंगिक श्रेणियाँ / Relevant Categories selected for notification	<ul style="list-style-type: none">• Single Burner Gas Range (for Deep Fryer)• Gas burners• Spirit Burner-IS:323
एमएसएमई के लिए अनुभव के वर्षों और टर्नओवर से छूट प्रदान की गई है/MSE Exemption for Years of Experience and Turnover	No
स्टार्टअप के लिए अनुभव के वर्षों और टर्नओवर से छूट प्रदान की गई है /Startup Exemption for Years of Experience and Turnover	No

बिड विवरण/Bid Details	
विक्रेता से मांगे गए दस्तावेज़/Document required from seller	Experience Criteria,Bidder Turnover,Certificate (Requested in ATC),OEM Authorization Certificate,OEM Annual Turnover,Additional Doc 1 (Requested in ATC),Additional Doc 2 (Requested in ATC),Additional Doc 3 (Requested in ATC),Additional Doc 4 (Requested in ATC) *In case any bidder is seeking exemption from Experience / Turnover Criteria, the supporting documents to prove his eligibility for exemption must be uploaded for evaluation by the buyer
क्या आप निविदाकारों द्वारा अपलोड किए गए दस्तावेज़ों को निविदा में भाग लेने वाले सभी निविदाकारों को दिखाना चाहते हैं? संदर्भ मेन् है/Do you want to show documents uploaded by bidders to all bidders participated in bid?	No
बिड लगाने की समय-सीमा बढ़ाने के लिए आवश्यक न्यूनतम सहभागी विक्रेताओं की संख्या। / Minimum number of bids required to disable automatic bid extension	2
दिनों की संख्या, जिनके लिए बिड लगाने की समय-सीमा बढ़ाई जाएगी। / Number of days for which Bid would be auto-extended	7
बिड से रिवर्स नीलामी सक्रिय किया/Bid to RA enabled	No
बिड का प्रकार/Type of Bid	Two Packet Bid
तकनीकी मूल्यांकन के दौरान तकनीकी स्पष्टीकरण हेतु अनुमत समय /Time allowed for Technical Clarifications during technical evaluation	5 Days
निरीक्षण आवश्यक (सूचीबद्ध निरीक्षण प्राधिकरण /जेम के साथ पूर्व पंजीकृत एजेंसियों द्वारा)/Inspection Required (By Empanelled Inspection Authority / Agencies pre-registered with GeM)	No
Payment Timelines	Payments shall be made to the Seller within 21 days of issue of consignee receipt-cum-acceptance certificate (CRAC) and on-line submission of bills (This is in supersession of 10 days time as provided in clause 12 of GeM GTC)
मूल्यांकन पद्धति/Evaluation Method	Total value wise evaluation
मध्यस्थता खंड/Arbitration Clause	No
सुलह खंड/Mediation Clause	No

ईएमडी विवरण/EMD Detail

एडवाइजरी बैंक/Advisory Bank	ICICI
ईएमडी राशि/EMD Amount	316108

ईपीबीजी विवरण /ePBG Detail

एडवाइजरी बैंक/Advisory Bank	ICICI
ईपीबीजी प्रतिशत (%) /ePBG Percentage(%)	5.00
ईपीबीजी की आवश्यक अवधि (माह) /Duration of ePBG required (Months).	25

(a). जेम की शर्तों के अनुसार ईएमडी छूट के इच्छुक बिडर को संबंधित कैटेगरी के लिए बिड के साथ वैध समर्थित दस्तावेज़ प्रस्तुत करने है। एमएसई कैटेगरी के अंतर्गत केवल वस्तुओं के लिए विनिर्माता तथा सेवाओं के लिए सेवा प्रदाता ईएमडी से छूट के पात्र हैं। व्यापारियों को इस नीति के दायरे से बाहर रखा गया है।/EMD EXEMPTION: The bidder seeking EMD exemption, must submit the valid supporting document for the relevant category as per GeM GTC with the bid. Under MSE category, only manufacturers for goods and Service Providers for Services are eligible for exemption from EMD. Traders are excluded from the purview of this Policy.

(b). ईएमडी और संपादन जमानत राशि, जहां यह लागू होती है, लाभार्थी के पक्ष में होनी चाहिए। / EMD & Performance security should be in favour of Beneficiary, wherever it is applicable.

लाभार्थी /Beneficiary :

GENERAL MANAGER -MATERIALS (HOD)

Mr. Sathiyaraj.F, Senior Manager-Materials (F.D.), Foreign Purchase Section, Materials Department, Oil India Limited, Field Head Quarters, Duliajan P.O., Dibrugarh District, Assam, India - 786602 Tel: +91-374-2808741 (PR No.: 1427543 / Table: FP-08)

(General Manager-materials Hod)

विभाजन/Splitting

बोली विभाजन लागू नहीं किया गया/ Bid splitting not applied.

एमआईआई खरीद वरीयता/MII Purchase Preference

एमआईआई खरीद वरीयता/MII Purchase Preference	Yes
--	-----

एमएसई खरीद वरीयता/MSE Purchase Preference

एमएसई खरीद वरीयता/MSE Purchase Preference	Yes
---	-----

1. Preference to Make In India products (For bids < 200 Crore): Preference shall be given to Class 1 local supplier as defined in public procurement (Preference to Make in India), Order 2017 as amended from time to time and its subsequent Orders/Notifications issued by concerned Nodal Ministry for specific Goods/Products. The minimum local content to qualify as a Class 1 local supplier is denoted in the bid document. If the bidder wants to avail the Purchase preference, the bidder must upload a certificate from the OEM regarding the percentage of the local content and the details of locations at which the local value addition is made along with their bid, failing which no purchase preference shall be granted. In case the bid value is more than Rs 10 Crore, the declaration relating to percentage of local content shall be certified by the statutory auditor or cost auditor, if the OEM is a company and by a practicing cost accountant or a chartered accountant for OEMs other than companies as per the Public Procurement (preference to Make-in -India) order 2017 dated 04.06.2020. Only Class-I and Class-II Local suppliers as per MII order dated 4.6.2020 will be eligible to bid. Non - Local suppliers as per MII order dated 04.06.2020 are not eligible to participate. However, eligible micro and small enterprises will be allowed to participate .The

buyers are advised to refer the OM No.F.1/4/2021-PPD dated 18.05.2023.

[OM No.1 4 2021 PPD dated 18.05.2023](#) for compliance of Concurrent application of Public Procurement Policy for Micro and Small Enterprises Order, 2012 and Public Procurement (Preference to Make in India) Order, 2017.

2. Purchase preference will be given to MSEs having valid Udyam Registration and whose credentials are validated online through Udyam Registration portal as defined in Public Procurement Policy for Micro and Small Enterprises (MSEs) Order, 2012 dated 23.03.2012 issued by Ministry of Micro, Small and Medium Enterprises and its subsequent Orders/Notifications issued by concerned Ministry. If the bidder wants to avail themselves of the Purchase preference, the bidder must be the manufacturer / OEM of the offered product on GeM. Traders are excluded from the purview of Public Procurement Policy for Micro and Small Enterprises and hence resellers offering products manufactured by some other OEM are not eligible for any purchase preference. In respect of bid for Services, the bidder must be the Service provider of the offered Service. Relevant documentary evidence in this regard shall be uploaded along with the bid in respect of the offered product or service and Buyer will decide eligibility for purchase preference based on documentary evidence submitted, while evaluating the bid. If L-1 is not an MSE and MSE Seller (s) has / have quoted price within L-1+ 15% (Selected by Buyer) of margin of purchase preference /price band defined in relevant policy, such MSE Seller shall be given opportunity to match L-1 price and contract will be awarded for 100% (selected by Buyer) percentage of total quantity. The buyers are advised to refer the OM No. F.1/4/2021-PPD dated 18.05.2023 [OM No.1 4 2021 PPD dated 18.05.2023](#) for compliance of Concurrent application of Public Procurement Policy for Micro and Small Enterprises Order, 2012 and Public Procurement (Preference to Make in India) Order, 2017. Benefits of MSE will be allowed only if seller is validated on-line in GeM profile as well as validated and approved by Buyer after evaluation of documents submitted.

3. Estimated Bid Value indicated above is being declared solely for the purpose of guidance on EMD amount and for determining the Eligibility Criteria related to Turn Over, Past Performance and Project / Past Experience etc. This has no relevance or bearing on the price to be quoted by the bidders and is also not going to have any impact on bid participation. Also this is not going to be used as a criteria in determining reasonableness of quoted prices which would be determined by the buyer based on its own assessment of reasonableness and based on competitive prices received in Bid / RA process.

Supply, Installation And Commissioning, Training Of Electronic Burner Management System (6 pieces)

(क्रमशः श्रेणी 1 और श्रेणी 2 के स्थानीय आपूर्तिकर्ता के रूप में अर्हता प्राप्त करने के लिए आवश्यक/Minimum 50% and 20% Local Content required for qualifying as Class 1 and Class 2 Local Supplier respectively)

तकनीकी विशिष्टियाँ /Technical Specifications

क्रेता विशिष्टि दस्तावेज़ /Buyer Specification Document	Download
---	--------------------------

उपरोक्त मद के लिए इंस्टॉलेशन कमीशनिंग एंड टेस्टिंग (आईसीटी) का विवरण / Installation Commissioning and Testing (ICT) details for the above item:

% of Product Cost Payable on Product Delivery	80%
Min Cost Allocation for ICT as a % of product cost	12%
Number of days allowed for ICT after site readiness communication to seller	60 Days

परेषिती/रिपोर्टिंग अधिकारी तथा मात्रा/Consignees/Reporting Officer and Quantity

क्र.सं./S.N o.	परेषिती/रिपोर्टिंग अधिकारी /Consignee Reporting/Officer	पता/Address	मात्रा /Quantity	डिलीवरी के दिन/Delivery Days
1	Ratandeep Gogoi	786602,Oil India Limited, Duliajan, Assam	6	196

Buyer added Bid Specific Additional Scope of Work

क्र.सं./S.N o.	Document Title	Description	रिवर्स प्रभार के अनुसार जीएसटी/Applicable i.r.o. Items
1	SCOPE OF SUPPLY, ADDITIONAL TERMS AND CONDITIONS, TECHNICAL SPECIFICATION View	The bidder shall carefully read this document and submit bid as per NIT requirements along with all supporting documents (As applicable). Note- The attached document is deemed to be part of the tendered item specification. Bidder is advised to check the delivery location and delivery period which varies itemwise and bid shall be submitted accordingly.	Supply, Installation And Commissioning, Training Of Electronic Burner Management System(6)

The uploaded document only contains Buyer specific Additional Scope of Work and / or Drawings for the bid items added with due approval of Buyer's competent authority. Buyer has certified that these additional scope and drawings are generalized and would not lead to any restrictive bidding.

क्रेता द्वारा जोड़ी गई बिड की विशेष शर्तें/Buyer Added Bid Specific Terms and Conditions

1. Generic

OPTION CLAUSE: The Purchaser reserves the right to increase or decrease the quantity to be ordered up to 25 percent of bid quantity at the time of placement of contract. The purchaser also reserves the right to increase the ordered quantity up to 25% of the contracted quantity during the currency of the contract at the contracted rates. The delivery period of quantity shall commence from the last date of original delivery order and in cases where option clause is exercised during the extended delivery period the additional time shall commence from the last date of extended delivery period. The additional delivery time shall be $(\text{Increased quantity} \div \text{Original quantity}) \times \text{Original delivery period (in days)}$, subject to minimum of 30 days. If the original delivery period is less than 30 days, the additional time equals the original delivery period. The Purchaser may extend this calculated delivery duration up to the original delivery period while exercising the option clause. Bidders must comply with these terms.

2. Generic

Bidder financial standing: The bidder should not be under liquidation, court receivership or similar proceedings, should not be bankrupt. Bidder to upload undertaking to this effect with bid.

3. Generic

Bidders shall quote only those products (Part of Service delivery) in the bid which are not obsolete in the market and has at least 5 years residual market life i.e. the offered product shall not be declared end-of-life by the OEM before this period.

4. Generic

Bidders are advised to check applicable GST on their own before quoting. Buyer will not take any responsibility in this regards. GST reimbursement will be as per actuals or as per applicable rates (whichever is lower), subject to the maximum of quoted GST %.

5. **Generic**

Buyer Organization specific Integrity Pact shall have to be complied by all bidders. Bidders shall have to upload scanned copy of signed integrity pact as per Buyer organizations policy along with bid. [Click here to view the file](#)

6. **Generic**

Bidder shall submit the following documents along with their bid for Vendor Code Creation:

- a. Copy of PAN Card.
- b. Copy of GSTIN.
- c. Copy of Cancelled Cheque.
- d. Copy of EFT Mandate duly certified by Bank.

7. **Generic**

Manufacturer Authorization:Wherever Authorised Distributors/service providers are submitting the bid, Authorisation Form /Certificate with OEM/Original Service Provider details such as name, designation, address, e-mail Id and Phone No. required to be furnished along with the bid

8. **Generic**

Products supplied shall be nontoxic and harmless to health. In the case of toxic materials, Material Safety Data Sheet may be furnished along with the material.

9. **Generic**

Scope of supply includes Training: Number of employees to be trained

6
, Place for Training
OIL Duliajan
and Duration of training
2
days.

10. **Generic**

Supplier shall ensure that the Invoice is raised in the name of Consignee with GSTIN of Consignee only.

11. **Generic**

The buyer organization is an institution eligible for concessional rates of GST as notified by the Government of India. The goods for which bids have been invited fall under classification of GST concession and the conditions for eligibility of concession are met by the institution. A certificate to this effect will be issued by Buyer to the Seller after award of the Contract. Sellers are requested to submit their bids after accounting for the Concessional rate of GST.
Applicable Concessional rate of GST :

12
%
Notification No.and date :
08/2022
dated
13/07/2022

12. **Generic**

1. The Seller shall not assign the Contract in whole or part without obtaining the prior written consent of

buyer.

2. The Seller shall not sub-contract the Contract in whole or part to any entity without obtaining the prior written consent of buyer.

3. The Seller shall, notwithstanding the consent and assignment/sub-contract, remain jointly and severally liable and responsible to buyer together with the assignee/ sub-contractor, for and in respect of the due performance of the Contract and the Sellers obligations there under.

13. **Generic**

Without prejudice to Buyer's right to price adjustment by way of discount or any other right or remedy available to Buyer, Buyer may terminate the Contract or any part thereof by a written notice to the Seller, if:

i) The Seller fails to comply with any material term of the Contract.

ii) The Seller informs Buyer of its inability to deliver the Material(s) or any part thereof within the stipulated Delivery Period or such inability otherwise becomes apparent.

iii) The Seller fails to deliver the Material(s) or any part thereof within the stipulated Delivery Period and/or to replace/rectify any rejected or defective Material(s) promptly.

iv) The Seller becomes bankrupt or goes into liquidation.

v) The Seller makes a general assignment for the benefit of creditors.

vi) A receiver is appointed for any substantial property owned by the Seller.

vii) The Seller has misrepresented to Buyer, acting on which misrepresentation Buyer has placed the Purchase Order on the Seller.

14. **Generic**

While generating invoice in GeM portal, the seller must upload scanned copy of GST invoice and the screenshot of GST portal confirming payment of GST.

15. **Generic**

Wherever Essentiality Certificate is applicable (PEL/ML), successful bidder should provide Proforma Invoice for processing for EC application and material should be dispatched after receiving of EC from DGH. In view of the same, an ATC may be incorporated in GeM, viz, "BIDDER/OEM must provide Proforma Invoice for processing for EC application within

136

days from date of issue of GeM Contract and material should be dispatched after receiving of EC from DGH."

16. **Scope of Supply**

Scope of supply (Bid price to include all cost components) : Supply Installation Testing Commissioning of Goods and Training of operators and providing Statutory Clearances required (if any)

17. **Purchase Preference (Centre)**

Purchase preference to Micro and Small Enterprises (MSEs): Purchase preference will be given to MSEs as defined in Public Procurement Policy for Micro and Small Enterprises (MSEs) Order, 2012 dated 23.03.2012 issued by Ministry of Micro, Small and Medium Enterprises and its subsequent Orders/Notifications issued by concerned Ministry. If the bidder wants to avail the Purchase preference, the bidder must be the manufacturer of the offered product in case of bid for supply of goods. Traders are excluded from the purview of Public Procurement Policy for Micro and Small Enterprises. In respect of bid for Services, the bidder must be the Service provider of the offered Service. Relevant documentary evidence in this regard shall be uploaded along with the bid in respect of the offered product or service. If L-1 is not an MSE and MSE Seller (s) has/have quoted price within L-1+ 15% of margin of purchase preference /price band defined in relevant policy, such Seller shall be given opportunity to match L-1 price and contract will be awarded for percentage of 100% of total value.

18. **Certificates**

Bidder's offer is liable to be rejected if they don't upload any of the certificates / documents sought in the Bid document, ATC and Corrigendum if any.

19. **Certificates**

Material Test Certificate Should Be Sent Along with The Supply. The Material Will Be Checked by Buyer's Lab & the Results of the Lab will be the Sole Criteria for Acceptance of the Item.

20. **Certificates**

The bidder is required to upload, along with the bid, all relevant certificates such as BIS licence, type test certificate, approval certificates and other certificates as prescribed in the Product Specification given in the bid document.

21. **Warranty**

Warranty period of the supplied products shall be as given in specifications from the date of final acceptance of goods or after completion of installation, commissioning & testing of goods (if included in the scope of supply), at consignee location. OEM Warranty certificates must be submitted by Successful Bidder at the time of delivery of Goods. The seller should guarantee the rectification of goods in case of any break down during the guarantee period. Seller should have well established Installation, Commissioning, Training, Troubleshooting and Maintenance Service group in INDIA for attending the after sales service. Details of Service Centres near consignee destinations are to be uploaded along with the bid.

22. **Warranty**

Timely Servicing / rectification of defects during warranty period: After having been notified of the defects / service requirement during warranty period, Seller has to complete the required Service / Rectification within 15 days time limit. If the Seller fails to complete service / rectification with defined time limit, a penalty of 0.5% of Unit Price of the product shall be charged as penalty for each week of delay from the seller. Seller can deposit the penalty with the Buyer directly else the Buyer shall have a right to recover all such penalty amount from the Performance Security (PBG). Cumulative Penalty cannot exceed more than 10% of the total contract value after which the Buyer shall have the right to get the service / rectification done from alternate sources at the risk and cost of the Seller besides forfeiture of PBG. Seller shall be liable to re-imburse the cost of such service / rectification to the Buyer.

23. **Forms of EMD and PBG**

Bidders can also submit the EMD with Payment online through RTGS / internet banking in Beneficiary name

Oil India Limited
Account No.
10494832599
IFSC Code
SBIN0002053
Bank Name
State Bank of India
Branch address
SBI, Duliajan, Dibrugarh District, Assam-786602

Bidder to indicate bid number and name of bidding entity in the transaction details field at the time of on-line transfer. Bidder has to upload scanned copy / proof of the Online Payment Transfer along with bid.

24. **Forms of EMD and PBG**

Successful Bidder can submit the Performance Security in the form of Payment online through RTGS / internet banking also (besides PBG which is allowed as per GeM GTC). On-line payment shall be in Beneficiary name

Oil India Limited
Account No.
10494832599
IFSC Code
SBIN0002053
Bank Name
State Bank of India
Branch address

SBI, Duliajan, Dibrugarh District, Assam-786602

. Successful Bidder to indicate Contract number and name of Seller entity in the transaction details field at the time of on-line transfer. Bidder has to upload scanned copy / proof of the Online Payment Transfer in place of PBG within 15 days of award of contract.

25. Buyer Added Bid Specific ATC

Buyer uploaded ATC document [Click here to view the file.](#)

अस्वीकरण/Disclaimer

The additional terms and conditions have been incorporated by the Buyer after approval of the Competent Authority in Buyer Organization, whereby Buyer organization is solely responsible for the impact of these clauses on the bidding process, its outcome, and consequences thereof including any eccentricity / restriction arising in the bidding process due to these ATCs and due to modification of technical specifications and / or terms and conditions governing the bid. If any clause(s) is / are incorporated by the Buyer regarding following, the bid and resultant contracts shall be treated as null and void and such bids may be cancelled by GeM at any stage of bidding process without any notice:-

1. Definition of Class I and Class II suppliers in the bid not in line with the extant Order / Office Memorandum issued by DPIIT in this regard.
2. Seeking EMD submission from bidder(s), including via Additional Terms & Conditions, in contravention to exemption provided to such sellers under GeM GTC.
3. Publishing Custom / BOQ bids for items for which regular GeM categories are available without any Category item bunched with it.
4. Creating BoQ bid for single item.
5. Mentioning specific Brand or Make or Model or Manufacturer or Dealer name.
6. Mandating submission of documents in physical form as a pre-requisite to qualify bidders.
7. Floating / creation of work contracts as Custom Bids in Services.
8. Seeking sample with bid or approval of samples during bid evaluation process. (However, in bids for [attached categories](#), trials are allowed as per approved procurement policy of the buyer nodal Ministries)
9. Mandating foreign / international certifications even in case of existence of Indian Standards without specifying equivalent Indian Certification / standards.
10. Seeking experience from specific organization / department / institute only or from foreign / export experience.
11. Creating bid for items from irrelevant categories.
12. Incorporating any clause against the MSME policy and Preference to Make in India Policy.
13. Reference of conditions published on any external site or reference to external documents/clauses.
14. Asking for any Tender fee / Bid Participation fee / Auction fee in case of Bids / Forward Auction, as the case may be.
15. Buyer added ATC Clauses which are in contravention of clauses defined by buyer in system generated bid template as indicated above in the Bid Details section, EMD Detail, ePBG Detail and MII and MSE Purchase Preference sections of the bid, unless otherwise allowed by GeM GTC.
16. In a category based bid, adding additional items, through buyer added additional scope of work/ additional terms and conditions/or any other document. If buyer needs more items along with the main item, the same must be added through bunching category based items or by bunching custom catalogs or bunching a BoQ with the main category based item, the same must not be done through ATC or Scope of Work.

Further, if any seller has any objection/grievance against these additional clauses or otherwise on any aspect of this bid, they can raise their representation against the same by using the Representation window provided in the bid details field in Seller dashboard after logging in as a seller within 4 days of bid publication on GeM. Buyer is duty bound to reply to all such representations and would not be allowed to open bids if he fails to reply to such representations.

All GeM Sellers / Service Providers are mandated to ensure compliance with all the applicable laws / acts / rules including but not limited to all Labour Laws such as The Minimum Wages Act, 1948, The

Payment of Wages Act, 1936, The Payment of Bonus Act, 1965, The Equal Remuneration Act, 1976, The Payment of Gratuity Act, 1972 etc. Any non-compliance will be treated as breach of contract and Buyer may take suitable actions as per GeM Contract.

[यह बिड सामान्य शर्तों के अंतर्गत भी शासित है /This Bid is also governed by the General Terms and Conditions](#)

जेम की सामान्य शर्तों के खंड 26 के संदर्भ में भारत के साथ भूमि सीमा साझा करने वाले देश के बिडर से खरीद पर प्रतिबंध के संबंध में भारत के साथ भूमि सीमा साझा करने वाले देश का कोई भी बिडर इस निविदा में बिड देने के लिए तभी पात्र होगा जब वह बिड देने वाला सक्षम प्राधिकारी के पास पंजीकृत हो। बिड में भाग लेते समय बिडर को इसका अनुपालन करना होगा और कोई भी गलत घोषणा किए जाने व इसका अनुपालन न करने पर अनुबंध को तत्काल समाप्त करने और कानून के अनुसार आगे की कानूनी कार्यवाई का आधार होगा।/In terms of GeM GTC clause 26 regarding Restrictions on procurement from a bidder of a country which shares a land border with India, any bidder from a country which shares a land border with India will be eligible to bid in this tender only if the bidder is registered with the Competent Authority. While participating in bid, Bidder has to undertake compliance of this and any false declaration and non-compliance of this would be a ground for immediate termination of the contract and further legal action in accordance with the laws.

---धन्यवाद/Thank You---



OIL INDIA LIMITED
MATERIALS DEPARTMENT - FIELD HEAD QUARTERS,
P.O., DULIAJAN, DIBRUGARH DISTRICT, ASSAM – 786602
TEL: (+91) 374 2808741
EMAIL: materials@oilindia.in | f_sathiyaraj@oilindia.in

**FORWARDING LETTER, INSTRUCTION TO BIDDERS (ITB) AND
STANDARD BIDDING DOCUMENTS (SBDS)**

OIL INDIA LIMITED (OIL) is a premier National Oil Maharatna Company engaged in the business of Exploration, Production and Transportation of Crude Oil and Natural gas. A Maharatna Company under the Ministry of Petroleum and Natural gas, Government of India (GOI), with its Headquarters at Duliajan, Assam. Duliajan is connected by Air with nearest Airport at Dibrugarh, 45 km away.

In connection to its operations, OIL invites **DOMESTIC COMPETITIVE BIDS** from competent and experienced bidders through **GEM portal** for the items mentioned below. You are invited to submit your most competitive bid on or before the scheduled bid closing date and time through **GEM portal**. For your ready reference, few salient points of the Tender are highlighted below.

The tender documents & other corrigendum / addendum / amendments, etc. is available in **Government E-Market (GeM) portal (visit www.gem.gov.in)** for participation of prospective bidders and tender information will be available in Oil India Limited's website (**www.oil-india.com**) for reference. Bidders will have to download the tender document before the due date of submission and use the same for participating in the tender.



TENDER INFORMATION SUMMARY

(1)	Type of Bidding	: Single Stage – Two Bid System
(2)	Bid Security	: Applicable (As per Proforma – G(A) for BG). NOTE: Original Bank Guarantee (If Applicable) will have to be submitted directly to Oil India Limited on or before the Bid closing date and time, failing which the bid may be rejected. <i>(Exempted bidder shall submit bid security declaration as per prescribed format in Proforma-G(B))</i>
(3)	Bid Security Amount	: Rs. 3,16,108.00 (Indian Rupees Three Lakhs Sixteen Thousand One Hundred and Eight Only)
(4)	Bid Security Validity	: Bid Security (if applicable & if submitted) in the form of BG/e-PBG must be valid atleast for a period of 6 months from the date of original bid closing date of the tender.
(5)	Bid Submission Mode	: Bid shall be submitted only through Government E-Marketplace (GeM) portal (Visit www.gem.gov.in) Note: Bid in any other form / mode of submission other than through Government E-Market (GeM) portal will not be considered as valid for evaluation purpose.
(6)	Bid Opening Place	: Office of Head of Department (HoD), Materials Department, Field Head Quarters (FHQ), Oil India Limited, Duliajan P.O., Dibrugarh District, Assam, India - 786602
(7)	Bid Validity	: Bid should be valid for minimum 120 days from the actual bid closing date.
(8)	Performance Guarantee	: Applicable @ 5 % of Order value (As per Proforma – F for BG) Performance Security (if applicable) is to be furnished within 30 days after notification of the award and it should remain valid for a period of 03 (three) months beyond the date of completion of all contractual obligations of the supplier, including warranty / guarantee / defect liability period, etc. (if any).
(9)	Integrity Pact	: Applicable
(10)	Restrictions on procurement from a bidder of a country which shares land border with India	: Applicable
(11)	PPP-MII Purchase Preference	: Applicable
(12)	MSE Purchase Preference	: Applicable (100% of tender / order quantity)
(13)	Price Variation Clause	: Not Applicable



OIL INDIA LIMITED
MATERIALS DEPARTMENT - FIELD HEAD QUARTERS,
P.O., DULIAJAN, DIBRUGARH DISTRICT, ASSAM – 786602
TEL: (+91) 374 2808741
EMAIL: materials@oilindia.in | f_sathiyaraj@oilindia.in

(14)	Third Party Document Verification	: Not Applicable
(15)	Sustainable Development (SD) and Environment Social and Governance (ESG) policy post order Questionnaire	: Applicable in case of tender / order value exceeds Indian Rupees Twenty Crores (₹ 20,00,00,000.00)
(16)	Evaluation Method	: All the tendered item(s) shall be evaluated as per total value-wise evaluation method ; hence bidder(s) are requested to quote accordingly.
(17)	Inspection Method	: Consignee Inspection at Consignee's site (Default)
	Pre-Dispatch Inspection (PDI)	: Not Applicable
	Third Party Inspection (TPI)	: Not Applicable
(18)	Installation & Commissioning (I&C)	: Applicable
(19)	Pre-Bid Conference	: Not Applicable
(20)	Training	: Applicable
(21)	Annual Maintenance Contract (AMC)	: Not Applicable
(22)	Contact Details	: Mr. F. Sathiyaraj Senior Manager - Materials (F.P.) E-Mail: f_sathiyaraj@oilindia.in materials@oilindia.in Phone: +91-374-2808741
(23)	Technical Support regarding GeM Portal	: Email: helpdesk-gem[at]gov[dot]in Toll Free Numbers (Inbound): Call: 1800-419-3436 / 1800-102-3436 (9:00 am - 10:00 pm Mon to Sat)
(24)	Bids to be addressed to	: The Head of Department, Materials Department, Oil India Limited, Field Head Quarters, Duliajan P.O., Dibrugarh District, Assam, India -786602
(25)	Consignee address	: The General Manager – Materials, Receiving Section, Materials Department, Oil India Limited, Field Head Quarters, Duliajan P.O., Dibrugarh District, Assam, India -786602 Email : receiving_materials@oilindia.in
(26)	Payment term (Applicable for Domestic bidder)	: (i) Payments shall be made to the seller within 21 days of issue of Consignee Receipt-Cum-Acceptance Certificate (CRAC) and on-line submission of bills. (ii) Payment terms where installation and commissioning & Training is involved: Wherever installation and commissioning is involved, 80% payment shall be made against supply of materials and balance 20% after satisfactory commissioning at site along with the installation & commissioning charges. Payment towards training shall be released after successful completion of training.



OIL INDIA LIMITED
MATERIALS DEPARTMENT - FIELD HEAD QUARTERS,
P.O., DULIAJAN, DIBRUGARH DISTRICT, ASSAM – 786602
TEL: (+91) 374 2808741
EMAIL: materials@oilindia.in | f_sathiyaraj@oilindia.in

(27)	Payment currency	:	All payment against the order (if awarded) will be in Indian Rupees only unless or otherwise specified in tender.
(28)	Concessional GST benefit for supply of tendered good(s)	:	Applicable (Concessional GST @ 12% will be applicable only if total material value is more than Rs.1,00,000 (i.e. 1 Lakh & above). Otherwise, GST at actuals / merit rate will be reimbursed against submission of documentary evidence. Bidder is advised to take note of above and accordingly submit price bid).
(29)	Variance in quantity at the time of order placement	:	This tender has a provision for variation of quantity at the time of placement of order up to +/- 25%. The bids, however, will be evaluated based on the tendered quantity to decide the interse ranking of the bidder.
(30)	Variation of quantities during execution	:	The purchaser reserves right to increase or decrease the quantity of the required goods upto plus / minus 20 (twenty) per cent without any change in the terms and conditions and prices quoted by the bidders.
(31)	Clarification of tender documents / Amendment of tender documents	:	<p>(i) The prospective bidder requiring clarification on the tender documents may notify to the company in writing well before the due date of submission of bid to enable purchaser to give response in writing to the clarification sought by such bidder.</p> <p>(ii) The prospective bidder is advised to submit their queries in relation to the tender document atleast 5 (five) working days before the scheduled date of bid closing date.</p> <p>(iii) At any time prior to the deadline for submission of bids, the Company may, for any reason, whether at its own initiative or in response to a clarification requested by a prospective Bidder, modify the Bid Documents through issuance of an Addendum(s) / Corrigendum(s) / Amendment(s) and such Addendum(s) / Corrigendum(s)/ Amendment(s) will be published in the tender portal and hosted on OIL website only. No separate intimation shall be sent to the Bidders. Prospective bidders are requested to visit the website regularly to keep themselves updated. Bidders are expected to take the Addendum(s)/Corrigendum(s)/ Amendment(s) into account in preparation and submission of their bid.</p>
(32)	The tendered / ordered (if) goods shall be delivered to	:	<p>The General Manager – Materials, Receiving Section, Materials Department, Oil India Limited, Field Head Quarters, Duliajan P.O., Dibrugarh District, Assam, India -786602 (or) Any other Oil India Limited’s installation / operational site located in Assam / Arunachal Pradesh.</p> <p><i>The bidder is advised to consider appropriate freight & insurance charges (as applicable) in their quotation/ bid.</i></p>

Disclaimer: Refer all tender terms and conditions governing this tender for more information.



KEY CONTACT DETAILS				
Sl. No.	Subject	:	Contact details	
(1)	Tender and purchase order related correspondences	:	Name	Mr. F. Sathiyaraj
			Designation	Senior Manager - Materials (F.P.)
			Email Address	f_sathiyaraj@oilindia.in materials@oilindia.in
			Postal Address	Oil India Limited, Field Head Quarters, Materials Department, Foreign Purchase Section, Duliajan P.O., Dibrugarh District, Assam, India. Postal Code : 786602
			Telephone No.	+91-374-2808741
(2)	Consignment delivery / Gate Pass / Goods Receipt Note (GRN) / Consignee Receipt-Cum-Acceptance Certificate (CRAC) related correspondences	:	Name	-
			Designation	General Manager - Materials (Receiving)
			Email Address	receiving_materials@oilindia.in
			Postal Address	Oil India Limited, Field Head Quarters, Materials Department, Receiving Section, Duliajan P.O., Dibrugarh District, Assam, India. Postal Code : 786602
			Telephone No.	+91-374-2808706 / 2808739 /
(3)	Performance Security / Bank Guarantee related correspondences	:	Name	-
			Designation	General Manager (Finance & Accounts)
			Email Address	f&a_bg@oilindia.in
			Postal Address	Oil India Limited, Field Head Quarters, Finance & Accounts Department, Accounts Payable Section, Duliajan P.O., Dibrugarh District, Assam, India. Postal Code : 786602
			Telephone No.	+91-374-2806177 / 2806183
(4)	Bills / payment related queries	:	Name	-
			Designation	General Manager (Finance & Accounts)
			Email Address	f&a_ap@oilindia.in
			Postal Address	Oil India Limited, Field Head Quarters, Finance & Accounts Department, Accounts Payable Section, Duliajan P.O., Dibrugarh District, Assam, India. Postal Code : 786602
			Telephone No.	+91-374-2808581 / 2808572 / 2806182
IMPORTANT NOTES				
(1)	From the time of bid opening to the time of contract award, no bidder shall contact Oil India Limited on any matter related to the bid, except on request and prior written permission.			
(2)	Any effort by the bidder to influence Oil India Limited in bid evaluation, bid comparison or contract award decisions will vitiate the process and will result in the rejection of the bidder's bid and action shall be initiated as per the Oil India Limited's procedure for action in case Corrupt / Fraudulent / Collusive / Coercive practices in this regard apart from forfeiture of EMD/ Bid Security, if any.			



DISCLAIMER	
(1)	The firm(s) to whom no further business is to be given or dealings with whom have been banned / suspended are not eligible to participate in the tender and any bid received from such firm(s) shall not be considered.
(2)	<i>“If a firm quotes NIL charges / consideration, the bid shall be treated as unresponsive and will not be considered”</i>
(3)	<i>At any time prior to the deadline for submission of bids, the Company may, for any reason, whether at its own initiative or in response to a clarification requested by a prospective Bidder, modify the Bid Documents through issuance of an Addendum(s)/ Corrigendum(s)/ Amendment(s) and such Addendum(s)/ Corrigendum(s)/ Amendment(s) will be published in the tender portal and hosted on OIL website only. No separate intimation shall be sent to the Bidders. Prospective bidders are requested to visit the website regularly to keep themselves updated. Bidders are expected to take the Addendum(s)/ Corrigendum(s)/ Amendment(s) into account in preparation and submission of their bid.</i>
(4)	<i>The resultant contract / order will be interpreted under Indian laws.</i>
(5)	<p>(i) The prospective bidder requiring clarification on the tender documents may notify to the company in writing well before the due date of submission of bid to enable purchaser to give response in writing to the clarification sought by such bidder.</p> <p>(ii) The prospective bidder is advised to submit their queries in relation to the tender document atleast 5 (five) working days before the scheduled date of bid closing date.</p> <p>(iii) At any time prior to the deadline for submission of bids, the Company may, for any reason, whether at its own initiative or in response to a clarification requested by a prospective Bidder, modify the Bid Documents through issuance of an Addendum(s) / Corrigendum(s) / Amendment(s) and such Addendum(s) / Corrigendum(s) / Amendment(s) will be published in the tender portal and hosted on OIL website only. No separate intimation shall be sent to the Bidders. Prospective bidders are requested to visit the website regularly to keep themselves updated. Bidders are expected to take the Addendum(s)/Corrigendum(s)/ Amendment(s) into account in preparation and submission of their bid.</p>
(6)	This tender has a provision for variation of quantity at the time of placement of order up to +/- 25%. The bids, however, will be evaluated based on the tendered quantity to decide the interse ranking of the bidder.
(7)	Authorization to participate in the tender does not guarantee placement of order. Requests received from interested vendors after 10 days of publication of tender shall be considered for future tenders only, subject to meeting the above evaluation criteria.
(8)	<p>The bidder, after submitting its tender, is permitted to withdraw / alter / modify its tender up to the date & time of receipt of tender (bid closing date & time). Government E-Market (GeM) portal / OIL's e-procurement portal (As applicable) will not allow the withdrawal / alteration / modification of bids after the bid closing date & time has been reached and bids have been opened.</p> <p>Any withdrawal / amendment / modification received after the prescribed date & time of receipt of tenders are not to be considered and action will be taken as per Company's Banning Policy.</p>
(9)	Oil India Limited ('Buyer') reserves the right to share, communicate, quote, the information / documents / drawings submitted by bidder / seller with any external agency / organization for purpose of verification, validation, and investigation in the interest of the buyer organization. The bidder / seller by virtue of submitting bid against this tender abide by the buyer organization's right in this regard.



DISCLAIMER	
(10)	<p>Deviation to the following criteria mentioned in the tender document shall make the bid liable for rejection:</p> <ul style="list-style-type: none">(i) Firm price(ii) EMD / Bid Bond / Bid Security Declaration(iii) Scope of work(iv) Specifications(v) Price Schedule(vi) Delivery / Completion Schedule(vii) Period of Validity of Bid(viii) Liquidated Damages(ix) Performance Bank Guarantee / Security deposit(x) Guarantee of material / work(xi) Arbitration / Resolution of Dispute(xii) Force Majeure(xiii) Applicable Laws(xiv) Integrity Pact, if applicable(xv) Any other condition specifically mentioned in the tender documents elsewhere that non-compliance of the clause lead to rejection of the bid. <p>However, OIL reserves the sole right to decide on acceptance / rejection of any deviation to tendered requirements by bidder.</p>
(11)	<p>Regarding Annual Maintenance Contracts, the purchaser reserves its right to terminate the maintenance contract at any time after giving due notice without assigning any reason. The contractor will not be entitled to claim any compensation against such termination. However, while terminating the contract, if any payment is due to the contractor for maintenance services already performed in terms of the contract, these would be paid to it/him as per the contract terms</p>
(12)	<p>If any bidder refuses to sign the Integrity Pact (IP) or refuses to accept the provisions of Integrity Pact (IP), their offers will be rejected.</p>
(13)	<p>A suitable provision has been made this tender for enabling a bidder to submit a representation against the bidding conditions, bidding process and / or rejection of its bid. These provisions have a specific time frame mentioned in the tender document / E-Procurement portal in which buyer will address the bidder's questions. However, Oil India Limited (Buyer) reserves the sole right to decide on acceptance / rejection of any representation / questions by bidder against the tender.</p>
(14)	<p>The provisions in the Special Conditions of Contract (SCC) will supersede the corresponding provisions in the General Conditions of Contract (GCC).</p>
(15)	<p>Wherever installation and commissioning is applicable, OIL reserves the right to seek price break-up of quoted price by respective bidder after price bid opening against the tender.</p> <p>The total quoted price by respective bidder shall have the following price break-up:</p> <ul style="list-style-type: none">1) Price for Goods: 80% to 99% of total quoted price2) Price for Installation and Commissioning: 1% to 20% of total quoted price.

All other terms and conditions are as per General Terms and Conditions (Ref.: MM/GLOBAL/01/2005) available in Oil India Limited's official website (www.oil-india.com), General Terms and Conditions available in Government E-Marketplace (GeM) portal and various public procurement guidelines / policy issued by Oil India Limited / Government of India from time-to-time.



LIST OF ANNEXURES

ANNEXURES	
Annexure - I	: Price Break up
Annexure - II	: Technical & Commercial Checklist
Annexure - III	: General Conditions of Contract (GCC) & (Part-A) of Special Conditions of Contract (SCC)
Annexure - IV	: Policy for providing preference to Domestically Manufactured Iron & Steel Products (DMI & SP)
Annexure - V	: General Conditions of Contract (<i>For all services to be rendered including AMC</i>)
Annexure - VI	: Technical Specification, Scope of Work
Annexure - VII	: (Part-B) of Special terms & Conditions & Matrix
Annexure - VIII	: Bid Evaluation Criteria / Bid Rejection Criteria (BEC/BRC) & Matrix



LIST OF PROFORMAS

PROFORMAS	
Proforma - A	: Format for undertaking towards compliance of Financial Criteria
Proforma - B	: Format for Annual Turn Over and Net Worth Certificate
Proforma - C	: Format for Corporate Guarantee towards Financial Standing
Proforma - D	: Format for Integrity Pact
Proforma – E(I), E(II), E(III)	: Formats for undertaking towards compliance of restriction on procurement from a bidder of a country which shares a land border with India
Proforma – F (A)	: Format for Performance Security
Proforma – F (B)	: Format for "Insurance Surety Bond" For "Performance Security"
Proforma – G (A)	: Format for Bid Security
Proforma – G (B)	: Format for Bid Security Declaration
Proforma – G (C)	: Format for "Insurance Surety Bond" For "Bid Security"
Proforma - H	: Format for undertaking towards submission of authentic information/ documents
Proforma - I	: Format for Authorization letter For attending Tender Opening
Proforma – J	: Format for Exception / Deviation
Proforma – K	: Format for Undertaking for Local Content
Proforma - L	: Format for Power of Attorney / Authorization letter (Regarding authority for submission of bid)
Proforma – M	: Format for Bidders financial standing
Proforma – N	: Format for declaration of Blacklisting / Holiday Listing/ NCLT / NCLAT /DRT /DRAT/ Court Receivership/ Liquidation
Proforma – O	: Format for bidder’s information
Proforma – P	: Format for pre-bid queries from prospective bidder
Proforma – Q	: Format of Authorization & Backup Warranty by Manufacturers to Sole Selling Agent / Dealer / Distributer
Proforma – R (A,B,C)	: Proforma For Pre-Qualification Criteria (PQC) Document Details
Proforma – S	: Proforma for Sustainable Development (SD) and Environment Social and Governance (ESG) policy post order Questionnaire to vendors & suppliers
Proforma – T	: Proforma for undertaking on acceptance of OIL’s ‘Banning Policy’
Proforma – U	: Proforma For Undertaking from Third Party Inspection Agency



OIL INDIA LIMITED
MATERIALS DEPARTMENT - FIELD HEAD QUARTERS,
P.O., DULIAJAN, DIBRUGARH DISTRICT, ASSAM - 786602
TEL: (+91) 374 2808741
EMAIL: materials@oilindia.in | f_sathiyaraj@oilindia.in

PROFORMAS



OIL INDIA LIMITED
MATERIALS DEPARTMENT - FIELD HEAD QUARTERS,
P.O., DULIAJAN, DIBRUGARH DISTRICT, ASSAM - 786602
TEL: (+91) 374 2808741
EMAIL: materials@oilindia.in | f_sathiyaraj@oilindia.in

PROFORMA - A

FORMAT FOR CERTIFICATE OF COMPLIANCE OF FINANCIAL CRITERIA

(ON THE OFFICIAL PAD OF THE BIDDER TO BE EXECUTED BY THE AUTHORIZED SIGNATORY OF THE BIDDER)

Ref : Clause No. A.2 (3.0) - Financial Criteria of the BEC

Tender No. : _____

I the authorized signatory(s) of.....(Company or firm name of address) do hereby affirm and declare as under:-

The balance sheet/Financial Statements for the financial year _____ (as the case may be) has actually not been audited as on the Original Bid closing Date.

Place :.....

Date :.....

Signature of the authorized signatory

Note:

This certificate is to be issued only considering the time required for preparation of Financial Statements i.e. if the last date of preceding financial / accounting year falls within the preceding six months reckoned from the original bid closing date.



PROFORMA – B

CERTIFICATE OF ANNUAL TURNOVER & NETWORTH

TO BE ISSUED BY PRACTISING **CHARTERED ACCOUNTANTS' FIRM** ON THEIR LETTER HEAD

TO WHOM IT MAY CONCERN

This is to certify that the following financial positions extracted from the audited financial statements of M/s..... (Name of the Bidder) for the last three (3) completed accounting years up to **(as the case may be)** are correct.

YEAR	TURN OVER In INR (Rs.) Crores	NET WORTH In INR (Rs.) Crores

Annual Financial Turnover of the bidder from operations shall mean: "Aggregate value of the realization of amount made from the sale, supply or distribution of goods or on account of services rendered, or both, by the company (bidder) during a financial year" as per the Companies Act, 2013 Section 2 (91).

Net worth shall mean: "Share capital + Reserves created out of profits and securities Premium – Aggregate value of accumulated losses (excluding revaluation reserves) – deferred expenditure – Miscellaneous Expenditure to the extent not written off and carried forward Loss - Reserves created out of write back of depreciation and amalgamation"

Place:
Date:
UDIN:
Seal:

Membership Code & Registration No.:
Signature



PROFORMA – C

PARENT/ ULTIMATE PARENT/ HOLDING COMPANY'S CORPORATE GUARANTEE TOWARDS FINANCIAL STANDING (Delete whichever not applicable)

(TO BE EXECUTED ON COMPANY'S LETTER HEAD)

DEED OF GUARANTEE

THIS DEED OF GUARANTEE executed at this day of by M/s(mention complete name) a company duly organized and existing under the laws of (insert jurisdiction/country), having its Registered Office at.....herein after called "the Guarantor" which expression shall, unless excluded by or repugnant to the subject or context thereof, be deemed to include its successors and permitted assigns.

WHEREAS M/s. Oil India Limited (hereinafter referred to as OIL) has invited offers vide their Tender No..... for.....and M/s.....(Bidder) intends to bid against the said tender and desires to have Financial support of M/s..... [Parent / Ultimate Parent/Holding Company(Delete whichever not applicable)] and whereas Parent/Ultimate Parent/Holding Company(Delete whichever not applicable) represents that they have gone through and understood the requirements of subject tender and are capable and committed to provide the Financial support as required by the bidder for qualifying and successful execution of the contract, if awarded to the bidder.

Now, it is hereby agreed by the Guarantor to give this Guarantee and undertakes as follows:

1. The Guarantor confirms that the Bidder is a 100% subsidiary of the Guarantor.
2. The Guarantor agrees and confirms to provide the Audited Annual Reports of any of the preceding 03(three) financial/accounting years reckoned from the original bid closing date.
3. The Guarantor have an annual financial turnover of minimum INR..... Cr or USD during any of the preceding 03(three) financial/ accounting years reckoned from the original bid closing date.
4. Net worth of the Guarantor is positive for preceding financial/ accounting year.
5. The Guarantor undertakes to provide financial support to the Bidder for executing the project/job, in case the same is awarded to the Bidder.
6. The Guarantor represents that:
 - (a) this Guarantee herein contained shall remain valid and enforceable till the satisfactory execution and completion of the work (including discharge of the warranty obligations) awarded to the Bidder.
 - (b) the liability of the Guarantor, under the Guarantee, is limited to the 100% of the order value between the Bidder and OIL. This will, however, be in addition to the forfeiture of the Performance Guarantee furnished by the Bidder.
 - (c) this Guarantee has been issued after due observance of the appropriate laws in force in India.
 - (d) this Guarantee shall be governed and construed in accordance with the laws in force in India and subject to the exclusive jurisdiction of the courts of New Delhi, India.
 - (e) this Guarantee has been given without any undue influence or coercion, and that the Guarantor has fully understood the implications of the same.
 - (f) the Guarantor has the legal capacity, power and authority to issue this Guarantee and that giving of this Guarantee and the performance and observations of the obligations hereunder do not contravene any existing laws.

For and on behalf of (Parent/Ultimate Parent/ Holding Company) (Delete whichever not applicable) <u>Witness:</u> 1. 2.	For and on behalf of (Bidder) <u>Witness:</u> 1. 2.
---	--



PROFORMA – D

INTEGRITY PACT

Between

Oil India Limited (OIL) hereinafter referred to as "The Principal"

And

(Name of the bidder).....hereinafter referred to as "The Bidder"

Preamble:

The Principal intends to award, under laid down organizational procedures, contract/s for -----
------. The Principal values full compliance with all relevant laws and regulations, and the principles of economic use of resources, and of fairness and transparency in its relations with its Bidder/s.

In order to achieve these goals, the Principal cooperates with the renowned international Non-Governmental Organization "Transparency International" (TI). Following TI's national and international experience, the Principal will appoint an external independent Monitor who will monitor the tender process for compliance with the principles mentioned above.

Section: 1 -Commitments of the Principal

(1) The Principal commits itself to take all measures necessary to prevent corruption and to observe the following principles:

- (i)** No employee of the Principal, personally or through family members, will in connection with the tender for, or during execution of a contract, demand, take a promise for or accept, for him/herself or third person, any material or immaterial benefit which he/she is not legally entitled to.
- (ii)** The Principal will, during the tender process treat all Bidders with equity and reason. The Principal will in particular, before and during the tender process, provide to all Bidders the same information and will not provide to any Bidder confidential/additional information through which the Bidder could obtain an advantage in relation to the tender process.
- (iii)** The Principal will exclude from the process all known prejudiced persons.

(2) If the Principal obtains information on the conduct of any of its employees which is a criminal offence under the relevant Anti-Corruption Laws of India, or if there be a substantive suspicion in this regard, the Principal will inform the Chief Vigilance Officers and in addition can initiate disciplinary actions.

Section: 2 -Commitments of the Bidder/Contractor

(1) The Bidder commits itself to take all measures necessary to prevent corruption. During his participation in the tender process, the Bidder commits himself to observe the following principles:

- (i)** The Bidder will not, directly or through any other person or firm, offer, promise or give to any of the Principal's employees involved in the tender process or the execution of the contract or to any third person any material or immaterial benefit which he/she is not legally entitled to, in order to obtain in exchange any advantage of any kind whatsoever during the tender process or during subsequent contract execution, if awarded.



OIL INDIA LIMITED
MATERIALS DEPARTMENT - FIELD HEAD QUARTERS,
P.O., DULIAJAN, DIBRUGARH DISTRICT, ASSAM – 786602

TEL: (+91) 374 2808741

EMAIL: materials@oilindia.in | f_sathiyaraj@oilindia.in

- (ii) The Bidder will not enter with other Bidders into any undisclosed agreement or understanding, whether formal or informal. This applies in particular to prices, specifications, certifications, Subsidiary contracts, submission or non-submission of bids or any other actions to restrict competitiveness or to introduce cartelization in the bidding process.
 - (iii) The Bidder (s) will not commit any offence under the relevant Anticorruption Laws of India, further, the Bidder (s) will not use improperly, for purposes of competition or personal gain, or pass on to others, any information or document provided by the Principal as part of the business relationship, regarding plans, technical proposals and business details, including information contained or transmitted electronically.
 - (iv) The Bidder will, when presenting his bid, disclose any and all payments he has made, is committed to or intends to make to agents, brokers or any other intermediaries in connection with the award of the contract.
 - (v) Bidders to disclose any transgressions with any other public/government organization that may impinge on the anti-corruption principle. The date of such transgression, for the purpose of disclosure by the bidders in this regard, would be the date on which cognizance of the said transgression was taken by the competent authority. The period for which such transgressions (s) is/are to be reported by the bidders shall be the last **three years** to be reckoned from date of bid submission. The transgression (s), for which cognizance was taken even before the said period of three years, but are pending conclusion, shall also be reported by the bidders.
 - (vi) The Bidder (s) of foreign origin shall disclose the name and address of the Agents/ representatives in India, if any. Similarly, the Bidder (s) of Indian Nationality shall furnish the name and address of the foreign principals, if any. Further, all the payments made to the Indian agent/ representative have to be in India Rupees only.
 - (vii) Bidders not to pass any information provided by Principal as part of business relationship to others and not to commit any offence under PC/ IPC Act;
- (2) The Bidder will not instigate third persons to commit offences outlined above or be an accessory to such offences.
- (3) The Bidder signing Integrity Pact shall not approach the Courts while representing the matters to IEMs and he/she will await their decision in the matter.

Section 3 -Disqualification from tender process and exclusion from future Contracts

If the Bidder, before contract award has committed a transgression through a violation of Section 2 or in any other form such as to put his reliability or risibility as Bidder into question, the Principal is entitled to disqualify the Bidder from the tender process for such reason.

1. If the Bidder has committed a transgression through a violation of Section 2 such as to put his reliability or credibility into question, the Principal is entitled also to exclude the Bidder from future contract award processes. The imposition and duration of the exclusion will be determined by the severity of the transgression. The severity will be determined by the circumstances of the case, in particular the number of transgressions, the position of the transgressions within the company hierarchy of the Bidder and the amount of the damage. The exclusion will be imposed for a minimum of 6 months and maximum of 2 years.

2. The Bidder accepts and undertakes to respect and uphold the Principal's Absolute right to resort to and impose such exclusion and further accepts and undertakes not to challenge or question such exclusion on any ground, including the lack of any hearing before the decision to resort to such exclusion is taken. This undertaking is given freely and after obtaining independent legal advice.



3. If the Bidder can prove that he has restored/recouped the Damage caused by him and has installed a suitable corruption prevention system, the Principal may revoke the exclusion prematurely.
4. A transgression is considered to have occurred if in light of available evidence no reasonable doubt is possible.
5. Integrity Pact, in respect of a particular contract, shall be operative from the date Integrity Pact is signed by both the parties or as mentioned in Section 9- Pact Duration whichever is later. Any violation of the same would entail disqualification of the bidders and exclusion from future business dealings.

Section 4 -Compensation for Damages

- (1) If the Principal has disqualified the Bidder from the tender process prior to the award according to Section 3, the Principal is entitled to demand and recover from the Bidder liquidated damages equivalent to Earnest Money Deposit / Bid Security.
- (2) The bidder agrees and undertakes to pay the said amounts without protest or demur subject only to condition that if the Bidder can prove and establish that the exclusion of the Bidder from the tender process has caused no damage or less damage than the amount or the liquidated damages, the Bidder shall compensate the Principal only to the extent of the damage in the amount proved.

Section 5 -Previous transgression

- (1) The Bidder declares that no previous transgression occurred in the last 3 years with any other company in any country conforming to the TI approach or with any other Public Sector Enterprise in India that could justify his exclusion from the tender process.
- (2) If the Bidder makes incorrect statement on this subject, he can be disqualified from the tender process for such reason.

Section: 6 -Equal treatment of all Bidders/Contractor/Subcontractors

- (1) The Principal will enter into Pacts on identical terms with all bidders and contractors.
- (2) The Bidder undertake(s) to procure from all subcontractors a commitment in conformity with this Integrity Pact. The Bidder shall be responsible for any violation(s) of the provisions laid down in this agreement/Pact by any of its sub-contractors/sub-vendors.
- (3) The Principal will disqualify from the tender process all bidders who do not sign this Pact or violate its provisions.

Section: 7 -Criminal charges against violating Bidders/Contractors/ Subcontractors

If the Principal obtains knowledge of conduct of a Bidder, Contractor or Subcontractor, or of an employee or a representative or an associate of a Bidder, Contractor or Subcontractor, which constitutes corruption, or if the Principal has substantive suspicion in this regard, the Principal will inform the Vigilance Office.

Section: 8 -External Independent Monitor/Monitors

- (1) The Principal appoints competent and credible Independent External Monitor (IEM) for this Pact.



- (2) The Monitor is not subject to instructions by the representatives of the parties and performs his functions neutrally and independently. He reports to the Chairperson of the Board of the Principal.
- (3) The Bidder accepts that the Monitor has the right to access without restriction to all Project documentation of the Principal including that provided by the Bidder. The Bidder will also grant the Monitor, upon his request and demonstration of a valid interest, unrestricted and unconditional access to his project documentation. The same is applicable to Subcontractors. The Monitor is under contractual obligation to treat the information and documents of the Bidder/Contractor/Subcontractor with confidentiality.
- (4) The Principal will provide to the Monitor sufficient information about all meetings among the parties related to the Project provided such meetings could have an impact on the contractual relations between the Principal and the Bidder. The parties offer the Monitor the option to participate in such meetings.
- (5) As soon as the Monitor notices, or believes to notice, a violation of this agreement, he will so inform the Management of the Principal and request the Management to discontinue or heal the violation, or to take other relevant action. The monitor can in this regard submit non-binding recommendations. Beyond this, the Monitor has no right to demand from the parties that they act in a specific manner, refrain from action or tolerate action. However, the Independent External Monitor shall give an opportunity to the bidder to present its case before making its recommendations to the Principal.
- (6) The Monitor will submit a written report to the Chairperson of the Board of the Principal within 8 to 10 weeks from the date of reference or intimation to him by the 'Principal' and, should the occasion arise, submit proposals for correcting problematic situations.
- (7) If the Monitor has reported to the Chairperson of the Board a Substantiated suspicion of an offence under relevant Anti-Corruption Laws of India, and the Chairperson has not, within reasonable time, taken visible action to proceed against such offence or reported it to the Vigilance Office, the Monitor may also transmit this information directly to the Central Vigilance Commissioner, Government of India.
- (8) The word 'Monitor' would include both singular and plural.
- (9) In case of any complaints referred under IP Program, the role of IEMs is advisory and the advice of IEM is non-binding on the Organization. However, as IEMs are invariably persons with rich experience who have retired as senior functionaries of the government, their advice would help in proper implementation of the IP.

Section:9 -Pact Duration

This Pact begins when both parties have legally signed it. It expires for the Contractor 12 months after the last payment under the respective contract, and for all other Bidders 6 months after the contract has been awarded.

If any claim is made/ lodged during this time, the same shall be binding and continue to be valid despite the lapse of this pact as specified above, unless it is discharged/determined by Chairperson of the Principal.

Section:10 -Other provisions

(1) This agreement is subject to Indian Law. Place of performance and jurisdiction is the Registered Office of the Principal. The Arbitration clause provided in the main tender document / contract shall not be applicable for any issue / dispute arising under Integrity Pact.

(2) Changes and supplements as well as termination notices need to be made in writing. Side agreements have not been made.



(3) In case of a joint venture, all the partners of the joint venture should sign the Integrity Pact. **In case of sub-contracting, the principal contractor shall be solely responsible for the adherence to the provisions of IP by the sub-contractor (s).**

(4) Should one or several provisions of this agreement turn out to be invalid, the remainder of this agreement remains valid. In this case, the parties will strive to come to an agreement to their original intentions.

<p>..... For the Principal</p> <p>Date :</p> <p>Place :</p>	<p>..... For the Bidder/Contractor</p> <p>Witness 1:</p> <p>Witness 2:</p>
--	---



OIL INDIA LIMITED
MATERIALS DEPARTMENT - FIELD HEAD QUARTERS,
P.O., DULIAJAN, DIBRUGARH DISTRICT, ASSAM - 786602
TEL: (+91) 374 2808741
EMAIL: materials@oilindia.in | f_sathiyaraj@oilindia.in

PROFORMA - E (I)

**UNDERTAKING TOWARDS COMPLIANCE OF PROVISIONS FOR RESTRICTIONS ON
PROCUREMENT FROM A BIDDER OF A COUNTRY WHICH SHARES LAND BORDER WITH
INDIA**

(To be typed on the letter head of the bidder)

Ref. No : _____

Date : _____

Tender No. _____ Date: _____

**M/s. OIL INDIA LIMITED
MATERIALS DEPARTMENT,
DULIAJAN, ASSAM, INDIA**

Dear Sirs,

We, M/s _____, have read the clause regarding restrictions on procurement from a bidder of a country which shares a land border with India; we certify that we are not from such a country/or if from such a country, have been registered with the Competent Authority. We hereby certify that we fulfil all requirements in this regard and are eligible to be considered. *[wherever applicable, evidence of valid registration by the Competent Authority shall be attached]*

Yours faithfully,

For (type name of the firm here)

Signature of Authorised Signatory

Name:

Designation:

Phone No.

Place:

Date:

(Affix Seal of the Organization here, if applicable)



OIL INDIA LIMITED
MATERIALS DEPARTMENT - FIELD HEAD QUARTERS,
P.O., DULIAJAN, DIBRUGARH DISTRICT, ASSAM – 786602
TEL: (+91) 374 2808741
EMAIL: materials@oilindia.in | f_sathiyaraj@oilindia.in

PROFORMA – E (II)

UNDERTAKING FOR WORKS INVOLVING POSSIBILITY OF SUB-CONTRACTING

(To be typed on the letter head of the bidder)

Ref. No. : _____

Date : _____

Tender No. : _____

Date: _____

M/s. OIL INDIA LIMITED
MATERIALS DEPARTMENT,
DULIAJAN, ASSAM, INDIA

Dear Sirs,

We, M/s _____, have read the clause regarding restrictions on procurement from a bidder of a country which shares a land border with India and on sub-contracting to contractors from such-countries, we certify that we are not from such a country/or if from such a country, have been registered with the Competent Authority and will not sub-contract any work to a contractor from such countries unless such contractor is registered with the Competent Authority. We hereby certify that we fulfil all requirements in this regard and is eligible to be considered. *[wherever applicable, evidence of valid registration by the Competent Authority shall be attached]*

Yours faithfully,

For (type name of the firm here)

Signature of Authorized Signatory

Name:

Designation:

Phone No.

Place:

Date:

(Affix Seal of the Organization here, if applicable)



OIL INDIA LIMITED
MATERIALS DEPARTMENT - FIELD HEAD QUARTERS,
P.O., DULIAJAN, DIBRUGARH DISTRICT, ASSAM – 786602
TEL: (+91) 374 2808741
EMAIL: materials@oilindia.in | f_sathiyaraj@oilindia.in

PROFORMA – E (III)

ADDITIONAL UNDERTAKING BY BIDDER IN CASES OF SPECIFIED TRANSFER OF TECHNOLOGY

(To be typed on the letter head of the bidder)

Ref. No. : _____

Date : _____

Tender No. : _____

Date: _____

M/s. OIL INDIA LIMITED
MATERIALS DEPARTMENT,
DULIAJAN, ASSAM, INDIA

Dear Sir,

We, M/s _____, have read the clause regarding restrictions on procurement from a bidder having Transfer of Technology (ToT) arrangement. We certify that we do not have any ToT arrangement requiring registration with the competent authority.

OR

We, M/s _____, have read the clause regarding restrictions on procurement from a bidder having Transfer of Technology (ToT) arrangement. We certify that we have valid registration to participate in this procurement. *[Evidence of valid registration by the Competent Authority shall be attached]*

Yours faithfully,

For (type name of the firm here)

Signature of Authorised Signatory

Name:

Designation:

Phone No.

Place:

Date:

(Affix Seal of the Organization here, if applicable)



PROFORMA – F (A)

FORMAT FOR PERFORMANCE BANK GUARANTEE

To,
THE GENERAL MANAGER – MATERIALS (HOD)
OIL INDIA LIMITED, MATERIALS DEPARTMENT,
DULIAJAN, ASSAM, INDIA, PIN – 786602

WHEREAS.....(Name and address of Contractor) (hereinafter called “Contractor”) had undertaken, in pursuance of Contact No..... to execute (Name of Contract and Brief Description of the Work) (hereinafter called “the Contract”).

AND WHEREAS it has been stipulated by you in the said Contract that the Contractor shall furnish you with a Bank Guarantee as security for compliance with Contractor’s obligations in accordance with the Contract.

AND WHEREAS we (May incorporate the Bank Name) have agreed to give the Contractor such a Bank Guarantee; NOW THEREFORE we hereby affirm that we are Guarantors on behalf of the Contractor, up to a total of (Amount of Guarantee in figures)..... (in words), such amount being payable in the types and proportions of currencies in which the Contract price is payable, and we undertake to pay you, upon your first written demand and without cavil or arguments, any sum or sums within the limits of guarantee sum as aforesaid without your needing to prove or to show grounds or reasons for your demand for the sum specified therein. We hereby waive the necessity of your demanding the said debt from the Contractor before presenting us with the demand.

We further agree that no change or addition to or other modification of the terms of the Contract or the work to be performed thereunder or of any of the Contract documents which may be made between you and the Contractor shall in any way cease us from any liability under this guarantee, and we hereby waive notice of such change, addition or modification.

This guarantee is valid until the day of.....



The details of the Issuing Bank and Controlling Bank are as under:

A. Issuing Bank:

- BANK FAX NO:
- BANK EMAIL ID:
- BANK TELEPHONE NO:
- IFSC CODE OF THE BANK:

B. Controlling Office:

- Address of the Controlling Office of the BG issuing Bank:
- Name of the Contract Person at the Controlling Office with Mobile No. and e-mail address:

Notwithstanding anything contained herein:

- (a) Our liability under this Bank Guarantee shall be restricted up to Rs.....
- (b) This guarantee shall be valid till
- (c) We are liable to pay the guarantee amount or any part thereof under this Bank Guarantee only and only if you serve upon us a written claim or demand on or before(Date of Expiry of BG PLUS one year claim period).
- (d) At the end of the claim period that is on or after.....(Date of expiry of.....the Bank Guarantee Plus Minimum of 1 year claim period shall be stipulated) all your rights under this Guarantee shall stand extinguished and we shall be discharged from all our liabilities under this Guarantee irrespective of receipt of original Bank Guarantee duly discharged, by Bank.

Name of the Contact Person at the Controlling Office with Mobile No. and e-mail address:

SIGNATURE AND SEAL OF THE GUARANTORS

Designation :

Name of the Bank :

Address :

.....

.....



PROFORMA – F (A)

UNDERTAKING BY VENDOR ON SUBMISSION OF BANK GUARANTEE

To,
Oil India Limited,
Materials Department,
Duliajan, Assam - 786602

We, M/s..... are submitting the Bid Security/Performance Security (strike out whichever not applicable) in favour of Oil India Limited, Duliajan in the form of bank guarantee bearing Reference No..... for an amount of INR.....valid up to as per terms and conditions of Tender / Contract No.....

BG issuing bank details:

Bank:	
Branch:	
IFS Code:	
Contact Details	
E-mail Addresses:	Mobile No.:
	Telephone No.: Fax
	No.:
Correspondence Address	
H No/Street/City:	State:
	Country: Pin
	Code:

Declaration

We have arranged to send the confirmation of issuance of the bank guarantee via SFMS portal through our bank using the details mentioned in the tender and hereby confirming the correctness of the details mentioned.

Authorized Signature : _____
Name : _____
Vendor Code : _____
Email ID : _____
Mobile No. : _____

Enclosure : **Original bank guarantee**



PROFORMA – F (B)

PROFORMA OF "INSURANCE SURETY BOND" FOR "PERFORMANCE SECURITY"

(To be stamped in accordance with the Stamp Act)

To The General Manager, Materials Department, M/s Oil India Limited, Field Head Quarters, Duliajan P.O., Dibrugarh District, Assam, India – 786602.	Insurance Surety Bond (ISB) No.	
	Date of ISB	
	ISB Valid up to (Expiry date)	
	Claim period up to (indicate date of expiry of claim period which includes minimum three months from the expiry date)	
	Stamp Sl. No./e-Stamp Certificate No.	

WHEREAS, (Name and address of Contractor) _____ (hereinafter called "Contractor") had undertaken, in pursuance of Contact No. _____ to execute (Name of Contract and Brief Description of the Work) _____ (hereinafter called "the Contract").

AND WHEREAS it has been stipulated by you in the said Contract that the Contractor shall furnish you with an Insurance Surety Bond (ISB) as security for compliance with Contractor's obligations in accordance with the Contract.

AND WHEREAS we (May incorporate the Insurer) have agreed to give the Contractor such an Insurance Surety Bond; NOW THEREFORE we hereby affirm that we are Insurer on behalf of the Contractor, up to a total of (Amount of ISB in figures) _____ (in words _____), such amount being payable in the types and proportions of currencies in which the Contract price is payable, and we, undertake to pay you, upon your first written demand stating the default/breach committed by the Contractor without cavil or arguments, any sum or sums within the limits of guarantee sum as aforesaid without your needing to prove or to show grounds or reasons for your demand for the sum specified therein. We hereby waive the necessity of your demanding the said debt from the Contractor before presenting us with the demand.

We further agree that no change or addition to or other modification of the terms of the Contract or the work to be performed thereunder or of any of the Contract documents which may be made between you and the Contractor shall in any way cease us from any liability under this ISB, and we hereby waive notice of such change, addition or modification.



NOW, THEREFORE, the Surety Insurer hereby, unconditionally and irrevocably, guarantees and affirms as follows:

1. The Surety Bond shall not be affected by any change in the constitution or winding up of the Contractor or the Surety Insurer or any absorption, merger or amalgamation of the Contractor or the Surety Insurer with any other person.
2. In order to give full effect to this Surety Bond, the Company shall be entitled to treat the Surety Insurer as the principal debtor.
3. The Surety Insurer declares that it has the power to issue this Surety Bond and discharge the obligations contemplated herein, the undersigned is duly authorised and has full power to execute this Surety Bond for and on behalf of the Surety Insurer.
4. Notwithstanding anything contained herein:
 - a) The Insurer’s liability under this Insurance Surety Bond shall not exceed (currency in figures) (currency in words only)
 - b) This Insurance Surety Bond shall remain in force upto ___ and any extension(s) thereof; and
 - c) The Surety insurer shall be released and discharged from all liability under this Insurance Surety Bond unless a written claim or demand is issued to the insurer on or before the midnight of(indicate date of expiry of claim period which includes minimum **three months** from the expiry of this Insurance Surety Bond) and any extension(s) thereof. If a claim has been received by us within the said date, all the rights of Company under this Insurance Surety Bond shall be valid and shall not cease until we have satisfied that claim.

In witness whereof the insurer, through its authorized officer, has set its hand and stamp on this _____ day of _____ 20__ at _____.

Witness:

Issuing Authority:

.....
(Signature)

.....
(Signature of the Authorised Signatory)

.....
(Name)

.....
(Name)

.....
(Designation & official address)

.....
(Designation with Insurer Stamp)

Authorised Vide
 Power of Attorney No.....
 Date.....



INSTRUCTIONS FOR FURNISHING "PERFORMANCE SECURITY DEPOSIT" BY "INSURANCE SURETY BOND"

- a) The Insurance Surety Bond shall be from an Insurer as per guidelines issued by Insurance Regulatory and Development Authority of India (IRDAI).
- b) The Company shall be the Creditor, the Contractor shall be the Principal debtor and the Insurance company/Insurer shall be the Surety in respect of the Insurance Surety Bond to be issued by the Insurer.
- c) The Insurance Surety Bond should be on Non-Judicial stamp paper/e-stamp paper of appropriate value as per Stamp Act prevailing in the state(s) where the Insurance Surety Bond is submitted or is to be acted upon or the rate prevailing in State where the Insurance Surety Bond is executed, whichever is higher. The Stamp Paper/e-stamp paper shall be purchased in the name of Contractor /Insurer issuing the Insurance Surety Bond.
- d) The expiry date and values should be arrived at in accordance with instructions provided in the "Forwarding Letter" of the Tender.
- e) The Insurance Surety Bond by Contractors will be given from Insurer as specified in the Tender.
- f) A letter from the issuing insurer of the requisite Insurance Surety Bond confirming that the said Insurance Surety Bond / all future communication relating to the Insurance Surety Bond shall be forwarded to the Purchaser at its address as mentioned at "ITB".
- g) Contractor must indicate the full postal address of the Insurer along with the Insurer 's E-mail / Phone from where the Insurance Surety Bond has been issued.
- h) Contractor must indicate Name, Address, Contact number and official Email ID of the Controlling Office of the Surety Issuing Branch or any web portal link, from whom / where the Surety Bond can be got confirmed by the Company.



PROFORMA – G (A)

BID SECURITY FORM

To:

M/s. OIL INDIA LIMITED,
MATERIALS DEPARTMENT

Whereas.....(hereinafter called 'the Bidder') has submitted their Bid No. dated..... against OIL INDIA LIMITED, DULIAJAN, ASSAM, INDIA (hereinafter called the Purchaser) 's Tender No. for the supply of (hereinafter called 'the Bid') KNOW ALL MEN by these presents.

That we of having our registered office at (hereinafter called 'the Bank') are bound unto the Purchaser, in the sum of for which payment well and truly to be made to the said Purchaser, the Bank binds itself, its successors and assigns by these presents.

Sealed with the said Bank thisday of

THE CONDITIONS of this obligation are:

1. If the Bidder withdraws their Bid during the period of Bid validity specified by the Bidder,
or
2. If the Bidder, having been notified of the acceptance of their bid by the Purchaser during the period of bid validity:
 - a) fails or refuses to accept the order; or
 - b) fails or refuses to furnish the performance securityor
3. If the Bidder furnishes fraudulent document/information in their bid.

We undertake to pay to the Purchaser up to the above amount upon receipt of their first written demand (by way of letter /fax/Email) without the Purchaser having to substantiate their demand, provided that in their demand the Purchaser will note that the amount claimed by it is due to it owing to the occurrence of any of the conditions, specifying the occurred condition or conditions.



This guarantee will remain in force up to and including
 (Bidder to indicate specific date as mentioned in the tender), and any demand in respect thereof should reach the Bank not later than the above date.

The details of the Issuing Bank and Controlling Bank are as under:

- A.** Issuing Bank :
 BANK FAX NO :
 BANK EMAIL ID :
 BANK TELEPHONE NO. :
 IFSC CODE OF THE BANK :

- B.** Controlling Office :
 Address of the Controlling Office of the BG issuing Bank :

Name of the Contact Person at the Controlling Office with Mobile No. and e-mail address:

Notwithstanding anything contained herein:

- a)** Our liability under this Bank Guarantee shall is restricted up to Rs
- b)** This guarantee shall be valid till
- c)** We are liable to pay the guarantee amount or any part thereof under this Bank Guarantee only and only if you serve upon us a written claim or demand on or before **(Date of Expiry of BG PLUS one year claim period).**
- d)** At the end of the claim period that is on or after **(Date of expiry of the Bank Guarantee Plus Minimum of 1 year claim period shall be stipulated)** all your rights under this Guarantee shall stand extinguished and we shall be discharged from all our liabilities under this Guarantee irrespective of receipt of original Bank Guarantee duly discharged, by Bank.

Name of the Contact Person at the Controlling Office with Mobile No. and e-mail address:

SIGNATURE AND SEAL OF THE GUARANTORS _____

Designation : _____
Name of Bank : _____
Address : _____

Date : _____
Place : _____



PROFORMA – G (B)

BID SECURITY DECLARATION

To,

M/s. Oil India Limited

.....

Sub:

Tender No:

Dear Sir,

After examining/reviewing provisions of above referred tender documents (including all corrigendum/ Addendum), we M/s. (Name of Bidder) have submitted our offer/bid no.....

We, M/s. (Name of Bidder) hereby understand that, according to your conditions, we are submitting this Declaration for Bid Security.

We understand that we will be put on watch list/holiday/banning list (as per policies of OIL INDIA in this regard), if we are in breach of our obligation(s) as per following:

- (a)** have withdrawn/modified/amended, impairs or derogates from the tender, my/our Bid during the period of bid validity specified in the form of Bid; or
- (b)** having been notified of the acceptance of our Bid by the OIL INDIALIMITED during the period of bid validity:
 - (i)** fail or refuse to execute the Contract, if required, or
 - (ii)** fail or refuse to furnish the Contract Performance Security, in accordance provisions of tender document.
 - (iii)** Fail or refuse to accept ‘arithmetical corrections’ as per provision of tender document.
- (c)** having indulged in corrupt/fraudulent/collusive/coercive practice as per procedure.

Place: **[Signature of Authorized Signatory of Bidder]**

Date: **Name:**

Designation:

Seal:



PROFORMA – G (C)

PROFORMA OF "INSURANCE SURETY BOND" FOR "BID SECURITY"

(To be stamped in accordance with the Stamp Act)

To The General Manager, Materials Department, M/s Oil India Limited, Field Head Quarters, Duliajan P.O., Dibrugarh District, Assam, India – 786602.	Insurance Surety Bond (ISB) No.	
	Date of ISB	
	ISB Valid up to (Expiry date)	
	Claim period up to (indicate date of expiry of claim period which includes minimum three months from the expiry date)	
	Stamp Sl. No./e-Stamp Certificate No.	

WHEREAS, (Name of Bidder) _____
 (hereinafter called "the Bidder") has submitted their
 offer Dated _____ for the provision of certain services (hereinafter called
 "the Bid") against OIL INDIA LIMITED, Duliajan, Assam, India (hereinafter called the
 Company's) Tender No. _____ **KNOW**
ALL MEN BY these presents that we (Name & address of the "Insurer")

_____ having our registered office at _____

_____ (hereinafter called " Insurer "), its successors and assignees, unconditionally and irrevocably undertake to pay forthwith to the Company an amount of Rs.....
 (Rupees
 only) (hereinafter referred to as the "Surety Bond") as our primary obligation without any demur, reservation, recourse, contest or protest and without reference to the Bidder, if the Bidder shall fail to fulfil or comply with all or any of the conditions mentioned below or referred in the Tender document in this regards.

Any such written demand made by the Company stating that the Bidder is in default of the due and faithful fulfilment and compliance with the aforesaid conditions shall be final, conclusive and binding on the Surety Insurer.

SEALED with the said Insurer this ___ day of _____ 20_____

THE CONDITIONS of these obligations are:

1. If the Bidder withdraws their Bid within its original/extended validity; or
2. The Bidder modifies/revises their bid suomoto; or
3. The Bidder does not accept the contract; or
4. The Bidder does not furnish Performance Security Deposit within the stipulated time as per tender/contract; or
5. If it is established that the Bidder has submitted fraudulent documents or has indulged into corrupt and fraudulent practice.



NOW, THEREFORE, the Surety Insurer hereby, unconditionally and irrevocably, guarantees and affirms as follows:

1. The Surety Bond shall not be affected by any change in the constitution or winding up of the Contractor or the Surety Insurer or any absorption, merger or amalgamation of the Contractor or the Surety Insurer with any other person.
2. In order to give full effect to this Surety Bond, the Company shall be entitled to treat the Surety Insurer as the principal debtor.
3. The Surety Insurer declares that it has the power to issue this Surety Bond and discharge the obligations contemplated herein, the undersigned is duly authorised and has full power to execute this Surety Bond for and on behalf of the Surety Insurer.
4. Notwithstanding anything contained herein:
 - a) The Insurer’s liability under this Insurance Surety Bond shall not exceed (currency in figures) (currency in words only)
 - b) This Insurance Surety Bond shall remain in force upto ____ and any extension(s) thereof; and
 - c) The Surety insurer shall be released and discharged from all liability under this Insurance Surety Bond unless a written claim or demand is issued to the insurer on or before the midnight of(indicate date of expiry of claim period which includes minimum **three months** from the expiry of this Insurance Surety Bond) and any extension(s) thereof. If a claim has been received by us within the said date, all the rights of Company under this Insurance Surety Bond shall be valid and shall not cease until we have satisfied that claim.

In witness whereof the insurer, through its authorized officer, has set its hand and stamp on this _____ day of _____ 20__ at _____.

Witness:	Issuing Authority:
..... (Signature) (Signature of the Authorised Signatory)
..... (Name) (Name)
..... (Designation & official address) (Designation with Insurer Stamp)

Authorised Vide
 Power of Attorney No.....
 Date.....



INSTRUCTIONS FOR FURNISHING "BID SECURITY DEPOSIT" BY "INSURANCE SURETY BOND"

- a) The Insurance Surety Bond shall be from an Insurer as per guidelines issued by Insurance Regulatory and Development Authority of India (IRDAI).
- b) The Company shall be the Creditor, the Contractor shall be the Principal debtor and the Insurance company/Insurer shall be the Surety in respect of the Insurance Surety Bond to be issued by the Insurer.
- c) The Insurance Surety Bond should be on Non-Judicial stamp paper/e-stamp paper of appropriate value as per Stamp Act prevailing in the state(s) where the Insurance Surety Bond is submitted or is to be acted upon or the rate prevailing in State where the Insurance Surety Bond is executed, whichever is higher. The Stamp Paper/e-stamp paper shall be purchased in the name of Contractor /Insurer issuing the Insurance Surety Bond.
- d) The expiry date and values should be arrived at in accordance with instructions provided in the “Forwarding Letter” of the Tender.
- e) The Insurance Surety Bond by Contractors will be given from Insurer as specified in the Tender.
- f) A letter from the issuing insurer of the requisite Insurance Surety Bond confirming that the said Insurance Surety Bond / all future communication relating to the Insurance Surety Bond shall be forwarded to the Purchaser at its address as mentioned at "ITB".
- g) Contractor must indicate the full postal address of the Insurer along with the Insurer 's E-mail / Phone from where the Insurance Surety Bond has been issued.
- h) Contractor must indicate Name, Address, Contact number and official Email ID of the Controlling Office of the Surety Issuing Branch or any web portal link, from whom / where the Surety Bond can be got confirmed by the Company.



OIL INDIA LIMITED
MATERIALS DEPARTMENT - FIELD HEAD QUARTERS,
P.O., DULIAJAN, DIBRUGARH DISTRICT, ASSAM – 786602
TEL: (+91) 374 2808741
EMAIL: materials@oilindia.in | f_sathiyaraj@oilindia.in

PROFORMA – H

**FORMAT OF UNDERTAKING BY BIDDERS TOWARDS SUBMISSION OF AUTHENTIC
INFORMATION / DOCUMENTS**

(To be typed on the letter head of the bidder)

Ref. No : _____

Date: _____

To,

The General Manager (Materials)
Materials Department
Oil India Limited, Duliajan

Sub : Undertaking of authenticity of information/documents submitted

Ref : Your tender No.: _____ **Date:** _____

Sir,

With reference to our quotation no. dated..... against your above-referred tender, we hereby undertake that no fraudulent information/documents have been submitted by us.

We take full responsibility for the submission of authentic information/documents against the above cited bid.

We also agree that, during any stage of the tender/contract agreement, in case any of the information/documents submitted by us are found to be false/forged/fraudulent, OIL has right to reject our bid at any stage including forfeiture of our EMD and/or PBG and/or cancel the award of contract and/or carry out any other penal action on us, as deemed fit.

Yours faithfully,

For (type name of the firm here)

Signature of Authorised Signatory

Name :

Designation :

Phone No. :

Place :

Date :

(Affix Seal of the Organization here, if applicable)



PROFORMA - I

PROFORMA OF AUTHORISATION LETTER FOR ATTENDING TENDER OPENING

Ref No.:

Date :

To,
 The General Manager - Materials (HoD)
 Materials Department
 Oil India Limited,
 P.O. Duliajan, Dist. Dibrugarh,
 Assam, India, PIN-786602

Dear Sir,

Sub: OIL's Tender No. _____

For _____
 Mr/Ms./Mrs. _____ has
 been authorized to be present at the time of opening of above tender due on
 at on my / our behalf.

Yours faithfully,

Signature of Bidder

Name :
Designation :
For & on behalf of :

Copy to:

Mr _____ for information and
 for production before The General Manager-Materials (HoD) during the opening of bids.



PROFORMA – J

EXCEPTION / DEVIATION PROFORMA
(To be submitted in the letter head of the bidder)

OIL expects the bidders to fully accept the terms and conditions of the bidding documents. However, should the bidder experience some exception and deviations to the terms of the bidding documents, the same should be indicated here and put in unpriced bid. In order to be considered responsive, Bidder's offer must specifically include the following statement:

- (a) We certify that the rate(s) quoted by bidder against the tender is/are the same and not higher than those quoted with other Government, public sector or private organisations (Fall Clause).
- (b) We certify that our offer complies with all NIT requirements and specifications without any deviations.
- Or
- (c) We certify that our offer complies with all NIT requirements and specifications with the following deviations:

Clause No. of Bidding Document	Full compliance/ not agreed	Exception/ deviations taken by the Bidders	Remarks

Signature of Bidder

Name :
Designation :
For & on behalf of :

Seal of the company



OIL INDIA LIMITED
MATERIALS DEPARTMENT - FIELD HEAD QUARTERS,
P.O., DULIAJAN, DIBRUGARH DISTRICT, ASSAM – 786602
TEL: (+91) 374 2808741
EMAIL: materials@oilindia.in | f_sathiyaraj@oilindia.in

PROFORMA – K

UNDERTAKING FOR LOCAL CONTENT

(To be submitted in the letter head of the bidder)

Tender No.: _____

We, M/s. _____

(Name of the bidder) have submitted Bid against Tender No. _____

dated _____ for supply of _____.

We hereby undertake that we meet the mandatory minimum local content requirement as mandated by Public Procurement (Preference to Make in India) Order, 2017 of Department for Promotion of Industry and Internal Trade (DPIIT), Govt. of India as revised vide Order No. P-45021/ 2 / 2017-PP (BE-II) dated 16th September 2020 (and as amended time to time) with modifications as notified vide MoPNG Order No. FP-20013/2/2017-FP-PNG-Part (4) (E-41432) dated 26th April 2022 (including subsequent amendments thereof, if any). **The percentage of Local Content is _____ %.**

We further declare that the percentage of Local content for the tendered Goods/Services has been calculated in conjunction with the directive issued by Ministry of Petroleum and Natural Gas vide notification no. **FP-20013/2/2017-FP- PNG-Part (4) (E-41432) dated 26.03.2024.**

For and behalf of M/s. _____ **(type name of the firm here)**

Signature of Authorised Signatory

Name :

Designation :

Phone No. :

Place :

Date :

(Affix Seal of the Organization here, if applicable)



PROFORMA - L

LETTER OF AUTHORITY

Note:

This letter of authority shall be on printed letter head of the Bidder and shall be signed by a person competent and having the power of attorney (power of attorney shall be annexed) to bind such Bidder.

To,
The General Manager - Materials (HoD)
Materials Department
Oil India Limited,
P.O. Duliajan, Dist. Dibrugarh,
Assam, India, PIN-786602

Dear Sir,

Sub: OIL's Tender No. _____

We _____ of _____ confirm that Mr./Ms./Mrs. _____ (Name and address) is authorised to represent us to bid, negotiate and conclude the agreement on our behalf with you against OIL's Tender No. _____ for any commercial /Legal purpose etc.

We confirm that we shall be bound by all and whatsoever our said representative shall commit.

Authorised Person's Signature :
Name :
Designation :

Yours faithfully,

Signature :
Name & Designation :
For & on behalf of M/s. :



OIL INDIA LIMITED
MATERIALS DEPARTMENT - FIELD HEAD QUARTERS,
P.O., DULIAJAN, DIBRUGARH DISTRICT, ASSAM – 786602
TEL: (+91) 374 2808741
EMAIL: materials@oilindia.in | f_sathiyaraj@oilindia.in

PROFORMA – M

UNDERTAKING FOR BIDDERS FINANCIAL STANDING

(To be submitted in the letter head of the bidder)

To,
The General Manager - Materials (HoD)
Materials Department
Oil India Limited,
P.O. Duliajan, Dist. Dibrugarh,
Assam, India, PIN-786602

Dear Sir,

Sub: OIL's Tender No. _____

We, _____ (Name of the bidder)
have submitted Bid against Tender No. _____ dated
_____. We hereby undertake that we are not under liquidation, court receivership
or similar proceedings, we are not bankrupt.

Authorised Signatory

Name :

Designation :

Contact Address :

Contact Email :

Contact Telephone Number :

Seal of the company



PROFORMA – N

**PROFORMA OF DECLARATION THAT BIDDER IS NOT UNDER HOLIDAY LIST/ DELISTED/
BLACKLISTED/ DEBARRED**

(To be submitted in the letter head of the bidder)

To,
The Head of the Department,
Materials Department, Field Head Quarters,
Oil India Limited, Duliajan, Dibrugarh District,
Assam, India, Postal Code – 786602

Tender No. : _____

Tender Description : _____

Sub: Undertaking/Declaration regarding Holiday List, debarment etc.

Ref: Tender No. _____

- a) We, M/s. _____ (Name of the bidder) solemnly affirm that we have read and understood OIL's Banning Policy as available at OIL's website <https://www.oil-india.com/banning-policy> and accept the Banning Policy in toto without any demur, protest, reservations and agree to be bound by the said Policy.
- b) We, hereby declare that neither our company nor any of its allied concerns, partners or associates or directors or proprietors involved in any capacity, are currently put on holiday list/banning list by OIL debaring us/them from carrying on business dealings with OIL.
- c) We, also hereby declare that neither our company nor any of its allied concerns, partners or associates or directors or proprietors involved in any capacity, have not been involved in any previous transgressions in the last 3 years with any other company in any country conforming to the TI (Transparency International) approach or with any other Public Sector Enterprise in India that could justify his exclusion from the tender process.
- d) We, disclose the following allied concerns, partners or associates or directors or proprietors involved in any capacity in terms of the definition of Allied firms given in the "Banning Policy" of Oil India Limited:

Sl. No.	Name	Address	PAN No.	GST No.	OIL Vendor Code

Place: _____

Date: _____

(Name & Signature of the authorised
signatory of the bidder)



PROFORMA – O

BIDDER INFORMATION

(To be submitted as part of technical bid)

(On Company Letter-head)

(Along with supporting documents, if any)

Bidder's Name _____

[Address and Contact Details]

Bidder's Reference No. : _____ **Date:**

Tender Document No. : _____ **Date:**

Tender Title:

Note: Bidder shall fill in this Form following the instructions indicated below. No alterations to its format shall be permitted, and no substitutions shall be accepted. Bidder shall enclose certified copies of the documentary proof/ evidence to substantiate the corresponding statement wherever necessary and applicable. Bidder's wrong or misleading information shall be treated as a violation of the Code of Integrity. Such Bids shall be liable to be rejected as nonresponsive, in addition to other punitive actions provided for such misdemeanours in the Tender Document.

(Please tick appropriate boxes or strike out sentences/ phrases not applicable to you)

1) Bidder/ Contractor particulars:

- (a) Name of the Company:
- (b) Corporate Identity No. (CIN):
- (c) Registration, if any, with Oil India Limited:
- (d) GeM Supplier ID (if registered with GeM, it is mandatory at the time of placement of Contract)
- (e) Place of Registration/ Principal place of business / manufacture
- (f) Complete Postal Address:

- (g) Pin code/ ZIP code:
- (h) Telephone nos. (with country/ area codes):
- (i) Mobile Nos.: (with country/ area codes):
- (j) Contact persons/ Designation:
- (k) Email IDs:

2) Taxation Registrations:

- (a) PAN number:
- (b) Type of GST Registration as per the Act (Normal Taxpayer, Composition, Casual Taxable Person, SEZ, etc.):
- (c) GSTIN number: in Consignor and Consignee States
- (d) Registered/ Certified Works/ Factory where the Goods would be mainly manufactured and Place of Consignor for GST Purpose:
- (e) Contact Names, Nos. & email IDs for GST matters (Please mention primary and secondary contacts):

We solemnly declare that our GST rating on the GST portal/ Govt. official website is not negative/ blacklisted.

Documents to be submitted: Self-attested Copies of PAN card and GSTIN Registration.



3) Authorization of Person(s) signing the bid on behalf of the Bidder

- (a) Full Name: _____
(b) Designation: _____
(c) Signing as:

- A sole proprietorship firm. The person signing the bid is the sole proprietor/
constituted attorney of the sole proprietor,
 A partnership firm. The person signing the bid is duly authorised being a partner
to do so, under the partnership agreement or the general power of attorney,
 A company. The person signing the bid is the constituted attorney by a resolution
passed by the Board of Directors or in pursuance of the Authority conferred by
Memorandum of Association.

***Documents to be submitted: Registration Certificate/ Memorandum of Association/
Partnership Agreement/ Power of Attorney/ Board Resolution***

4) Bidder's Authorized Representative Information

- (a) Name:
(b) Address:
(c) Telephone/ Mobile numbers:
(d) Email Address:

(Signature with date)

.....

(Name and designation)

**Duly authorized to sign bid for and on behalf of
[name & address of Bidder and seal of company]**

DA: As above



OIL INDIA LIMITED
MATERIALS DEPARTMENT - FIELD HEAD QUARTERS,
P.O., DULIAJAN, DIBRUGARH DISTRICT, ASSAM - 786602
TEL: (+91) 374 2808741
EMAIL: materials@oilindia.in | f_sathiyaraj@oilindia.in

PROFORMA - P

FORMAT FOR PRE-BID QUERIES FROM PROSPECTIVE BIDDER

TENDER NO. :
ITEM :
BIDDER NAME : M/s.

Sl. No.	Tender Clause / Reference	As per tender	Query from prospective bidder
1)			
2)			
3)			

(Signature)

Name :
Designation :
Contact Email :
Contact Mobile Number :

Seal of the company

PROFORMA – Q

**FORMAT OF AUTHORIZATION & BACKUP WARRANTY BY MANUFACTURERS TO SOLE
SELLING AGENT / DEALER / DISTRIBUTOR**

(TO BE TYPED ON THE LETTER HEAD OF THE MANUFACTURER)

Ref. No.: _____

Date: _____

Sub: Authorization & Backup Warranty

Ref: Your tender No.: _____

Date: _____

To,
**The Head of Department,
Materials Department - Field Head Quarters (FHQ),
Oil India Limited, Duliajan P.O.,
Dibrugarh District, Assam, India - 786602**

Sir,

We, M/s (Name & address of the Manufacturer) hereby authorize M/s..... (Name & address of the Bidder) to submit their Bid against Tender No..... floated by M/s. OIL INDIA LIMITED (OIL) for supply tendered goods, which will be manufactured by us. As we do not participate directly against such tendering process, we authorize M/s. (name of the Bidder) to participate as our only Sole Selling Agent/Dealer/Distributor (strike out whichever is not applicable) against the tender.

We hereby guarantee the supply through M/s..... (name of the Bidder) in the event of placement of purchase order by OIL and shall provide all back-up supports as may be necessary including for the quality & workmanship of supplied materials.

This authorization and back-up warrantee/guaranty shall remain valid throughout the execution by M/s. (Name of the Bidder) including the defect liability and AMC period, in the event of an order by OIL on them.

Yours faithfully,
For (Name of the manufacturer)

Name & Signature of Authorized signatory :
Designation :
Phone No. :
Place :
Date :
Seal of the Manufacturer :

PROFORMA / SPECIMEN TEMPLATE FOR PRE-QUALIFICATION CRITERIA (PQC) DOCUMENT DETAILS (IF APPLICABLE)

TECHNICAL – PRE-QUALIFICATION CRITERIA (PQC)

Important Instructions:

Oil India Limited reserves the right to complete the evaluation w.r.t. "Pre-Qualification Criteria", based on the documents mentioned below only without taking cognizance of any other documents submitted towards "PQC", which is not mentioned below. In case required details are not mentioned in the relevant cells and merely enclosed/attached etc. is mentioned, Oil India Limited may not take cognizance of such documents during evaluation. Please submit details of only those complete documents for relevant orders etc., which you consider are meeting Oil India Limited's tender PQC requirements in toto. Oil India Limited ('Buyer')'s decision is final and binding by bidder/seller.

Sl. No.	Purchase Order No./Document name	PO. Dt.	PO ISSUED BY (client name) M/s.	Full address of the client and contact person (Name & Details i.e. Mail ID, Mobile No. etc)	Short description of Items under PO	Order Value (On FOR despatch point / FCA / FOB Port of exit basis)	Order execution /completion dt.	Documentary evidence as proof of execution/completion as mentioned in Tender PQC requirement

(SIGNATURE OF BIDDER WITH COMPANY SEAL)

PROFORMA / SPECIMEN TEMPLATE FOR PRE-QUALIFICATION CRITERIA (PQC) DOCUMENT DETAILS (IF APPLICABLE)

COMMERCIAL – PRE-QUALIFICATION CRITERIA (PQC)

Important Instructions:

Oil India Limited reserves the right to complete the evaluation w.r.t. "Pre-Qualification Criteria", based on the documents mentioned below only without taking cognizance of any other documents submitted towards "PQC", which is not mentioned below. In case required details are not mentioned in the relevant cells and merely enclosed/attached etc. is mentioned, Oil India Limited may not take cognizance of such documents during evaluation. Please submit details of only those complete documents for relevant orders etc., which you consider are meeting Oil India Limited's tender PQC requirements in toto. Oil India Limited ('Buyer')'s decision is final and binding by bidder/seller.

Sl. No.	Purchase Order No./Document name	PO. Dt.	PO ISSUED BY (client name) M/s.	Full address of the client and contact person (Name & Details i.e. Mail ID, Mobile No. etc)	Short description of Items under PO	Order Value (On FOR despatch point / FCA / FOB Port of exit basis)	Order execution /completion dt.	Documentary evidence as proof of execution/completion as mentioned in Tender PQC requirement

(SIGNATURE OF BIDDER WITH COMPANY SEAL)

PROFORMA / SPECIMEN TEMPLATE FOR PRE-QUALIFICATION CRITERIA (PQC) DOCUMENT DETAILS (IF APPLICABLE)

FINANCIAL – PRE-QUALIFICATION CRITERIA (PQC)

Important Instructions:

Oil India Limited reserves the right to complete the evaluation w.r.t. "Pre-Qualification Criteria", based on the documents mentioned below only without taking cognizance of any other documents submitted towards "PQC", which is not mentioned below. In case required details are not mentioned in the relevant cells and merely enclosed/attached etc. is mentioned, Oil India Limited may not take cognizance of such documents during evaluation. Please submit details of only those complete documents for relevant orders etc., which you consider are meeting Oil India Limited's tender PQC requirements in toto. Oil India Limited ('Buyer')'s decision is final and binding by bidder/seller.

Sl. No.	Financial Year	Details of Documentary evidence (i.e. audited balance sheet/ profit and loss statement of audited balance sheet / published annual report / balance sheet in public domain etc.)	Turnover (Rs.)	Remarks if any

(SIGNATURE OF BIDDER WITH COMPANY SEAL)

PROFORMA – S

SUSTAINABLE DEVELOPMENT (SD) AND ENVIRONMENT, SOCIAL AND GOVERNANCE (ESG) POLICY (IF APPLICABLE)

POST AWARD OF ORDER ESG QUESTIONNAIRE FOR SELLER / SUPPLIER
(To be typed and submitted in company letterhead of seller / supplier)

The successful bidder shall be required to submit a duly filled ESG Questionnaire in the prescribed format **within fifteen (15) calendar days** from the date of award of contract or issue of purchase order.

Failure to submit the completed ESG Questionnaire within the stipulated timeline may be treated as non-compliance with contractual obligations and dealt with accordingly.

Suppliers and vendors may refer to the Explanatory Note for any questions or clarifications pertaining to any of the questions below:

Questionnaire for vendors and suppliers	
Question	Response
1.0 Emissions	
1.1 What was the GHG emission for the last financial year (FY _____)?	
(a) Scope 1 GHG emissions (kg CO ₂ e)	
(b) Scope 2 GHG emissions (kg CO ₂ e)	
1.2 What was the GHG emission per unit of revenue for the last financial year (FY _____)?	
(a) Scope 1 GHG emissions (kg CO ₂ e)	
(b) Scope 2 GHG emissions (kg CO ₂ e)	

(SIGNATURE OF SELLER WITH COMPANY SEAL / STAMP)

Explanatory Note - ESG Questionnaire for Suppliers and Vendors

1 Emissions Reporting

What are Greenhouse Gas (GHG) Emissions?

Greenhouse gas (GHG) emissions refer to gases that trap heat in the Earth's atmosphere, contributing to global warming and climate change. These include carbon dioxide (CO₂), methane (CH₄), and nitrous oxide (N₂O), among others. GHG emissions are generated from various sources, such as burning fossil fuels, industrial activities, and deforestation.

What are Scope 1 and Scope 2 Emissions?

- **Scope 1 Emissions:** Direct emissions from sources owned or controlled by your company (e.g., fuel combustion in company-owned vehicles, boilers, and generators).
- **Scope 2 Emissions:** Indirect emissions from purchased electricity, steam, heating, and cooling consumed by your company. These emissions occur at the power generation source but are attributed to your business due to electricity consumption.

How to Calculate GHG Emissions?

Emissions are typically calculated using the following formula:

GHG Emissions (kg CO₂e) = Consumption data × Emission Factor

- **Consumption Data:** Fuel consumption (liters), electricity use (kWh), etc.
- **Emission Factor:** Standard values published by organizations like the IPCC

Examples:

1. **Fuel Consumption-Based Calculation (Scope 1):**
 - If you use 1,000 liters of diesel in company vehicles, and the emission factor for diesel is 2.68 kg CO₂e per liter, your emissions are:
 $1,000 \times 2.68 = 2,680 \text{ kg CO}_2\text{e}$
2. **Electricity Consumption-Based Calculation (Scope 2):**
 - If your facility consumes 5,000 kWh of electricity, and the emission factor for your electricity provider is 0.4 kg CO₂e per kWh, your emissions are:
 $5,000 \times 0.4 = 2,000 \text{ kg CO}_2\text{e}$

Sample Responses:

Question	Sample Response
What was the GHG emission for FY24?	a) Scope 1: 10,500 kg CO ₂ e
	b) Scope 2: 8,200 kg CO ₂ e
What was the GHG emission per unit revenue for FY24?	a) Scope 1: 2.5 kg CO ₂ e per INR 1,000 revenue
	b) Scope 2: 1.8 kg CO ₂ e per INR 1,000 revenue

PROFORMA – S

SUSTAINABLE DEVELOPMENT (SD) AND ENVIRONMENT, SOCIAL AND GOVERNANCE (ESG) POLICY

POST AWARD OF ORDER ESG QUESTIONNAIRE FOR SELLER / SUPPLIER
(To be typed and submitted in company letterhead of seller / supplier)

Questionnaire for vendors and suppliers	
Question	Response
2.0 Decarbonization strategies and targets	
2.1 Do you have a net zero target? If yes, please state the year.	
2.2 Do you have an emission reduction target? If yes, are the targets absolute emissions based or intensity based?	
2.3 Please state the target for reduction in next financial year (FY _____)?	
(a) Scope 1 GHG emissions / emissions intensity	
(b) Scope 2 GHG emissions / emissions intensity	
2.4 Please provide information on a few decarbonization initiatives undertaken (describe the initiatives and their respective impact).	

(SIGNATURE OF SELLER WITH COMPANY SEAL / STAMP)

Explanatory Note - ESG Questionnaire for Suppliers and Vendors

2 Decarbonization Strategy & Targets

Net Zero and Emission Reduction Targets

- **Net Zero Target:** A Net Zero target refers to a commitment to reducing emissions to as close to zero as possible, with residual emissions offset by carbon capture or other means. OIL would like to know if your organization has set any targets of becoming net zero, and if so, what is the targeted year.
- **There are 2 types of defining the target:**

Absolute Reduction: A fixed percentage decrease in emissions over a period (e.g., 10% reduction by 2030).

Intensity-Based Reduction: Reduction in emissions per unit of production or revenue (e.g., 15% reduction per product by 2025).

Sample Responses:

Question	Sample Response
Do you have a Net Zero target? If yes, please state the year	Yes, by 2040
Do you have an emissions reduction target? If yes, are the targets absolute emissions based, or intensity based?	Yes, we aim for an absolute 40% reduction by 2030, and 100% by 2040
Please state the target for reduction in FY24.	a) Scope 1: 10% absolute reduction
	b) Scope 2: 10% absolute reduction
Please provide information on a few initiatives undertaken (describe the initiatives)	Afforestation EV inclusion Electrification of gas-based equipment Renewable energy setup
How much of the reduction targets have been achieved till date? (eg: more than 80% achieved, less than 20% etc)	~5 % reduction has been achieved

PROFORMA - S

SUSTAINABLE DEVELOPMENT (SD) AND ENVIRONMENT, SOCIAL AND GOVERNANCE (ESG) POLICY

POST AWARD OF ORDER ESG QUESTIONNAIRE FOR SELLER / SUPPLIER
(To be typed and submitted in company letterhead of seller / supplier)

Questionnaire for vendors and suppliers	
Question	Response
3.0 Waste and water management	
3.1	Do you have any initiatives for waste management including solid wastes, liquid wastes and hazardous wastes?
3.2	Do you have any initiatives for water management including monitoring of water consumption and withdrawals, and if applicable, treatment of wastewater?

(SIGNATURE OF SELLER WITH COMPANY SEAL / STAMP)

Explanatory Note - ESG Questionnaire for Suppliers and Vendors

3. Waste & Water Management

Waste Management Initiatives

In order to answer the question regarding waste management initiatives, vendors and suppliers may mention few of the initiatives that their organizations have undertaken that may include (but are not limited to):

- Recycling and reusing materials
- Proper disposal of hazardous waste
- Reducing landfill waste through composting or waste-to-energy programs

Water Conservation Initiatives

Similar to the waste management initiatives, in order to answer the question regarding water conservation initiatives, vendors and suppliers may mention few of the initiatives that their organizations have undertaken that may include (but are not limited to):

- Monitoring water consumption with meters
- Installing water-efficient fixtures
- Treating wastewater before discharge

Sample Responses:

Question	Sample Response
Do you have any initiatives for waste management including solid wastes, liquid wastes and hazardous waste?	Yes, we recycle 60% of our production waste and have SOPs in place for proper dispose of hazardous materials.
Do you have any initiatives for water management including monitoring of water consumption and withdrawals, and if applicable, treatment of wastewater?	Yes, we have meters to monitor water withdrawals and have a wastewater treatment process.

PROFORMA – S

SUSTAINABLE DEVELOPMENT (SD) AND ENVIRONMENT, SOCIAL AND GOVERNANCE (ESG) POLICY

POST AWARD OF ORDER ESG QUESTIONNAIRE FOR SELLER / SUPPLIER
(To be typed and submitted in company letterhead of seller / supplier)

Questionnaire for vendors and suppliers	
Question	Response
4.0 Disclosures	
4.1	Are your current emission verified? If yes, please name the assuring body.
4.2	Are your emission targets validated? (Eg: SbTi)? If yes, please name the methodology?
4.3	Are you rated by any of the ESG rating agencies? if yes, please specify the agency and rating

(SIGNATURE OF SELLER WITH COMPANY SEAL / STAMP)

Explanatory Note - ESG Questionnaire for Suppliers and Vendors

4. Disclosures

Verification & Validation of Emissions Data

- **Current emissions verification:** There are certain third-party agencies that verify an organization's emissions. These organizations provide independent assessments to ensure transparency and accuracy in emissions reporting. Verification by such agencies enhances credibility and aligns businesses with best sustainability practices. In case your organization's current emissions are validated by such a third-party agency, please specify the name of such an agency.
- **Emissions target validation:** If you have a target of reducing your carbon footprint, certain organizations validate the roadmap of achieving a lower carbon footprint. In case you have prepared a roadmap and submitted it to SBTi or Transition Pathways Initiatives, and have received certificates that have validated the targets, please specify the agency that has validated your targets.
- **ESG Ratings:** Certain agencies assess organizations based on their disclosures, monitoring capabilities, and control measures, among other factors. Some of these agencies, such as CDP and S&P, are globally recognized for their ratings. If your organization has received a rating from any of these agencies, please specify the agency's name and your assigned rating.

Sample Responses:

Question	Sample Response
Are your current emissions verified? If yes, please name the assuring body	Yes, verified by XYZ agency
Are your emissions targets validated (eg: SbTi)? If yes, please name the methodology	Yes, validated by SBTi.
Are you rated by any of the ESGrating agencies? If yes, please specify the agency and rating	Yes, CDP rating: D.

PROFORMA – T

FORMAT FOR UNDERTAKING ON ACCEPTANCE OF OIL'S 'BANNING POLICY'
(To be typed on the Letterhead of the Bidder)

I _____, age _____ years Son/ Daughter of
_____, resident of
_____ do solemnly
affirm and state as under:

1. That _____ (*Name of the Bidder / Firm*) is desirous of submitting its bid against tender no _____ dated _____ for _____ item / works (*Name of tender*).
2. That I _____ is a Bidder/Authorized signatory of Bidder, and being duly authorized, I furnish this undertaking on behalf of Bidder.
3. That _____ (*Name of the Bidder/Firm*) has read, understood and accepts the OIL's Banning Policy as available at OIL's website (<https://www.oil-india.com/banning-policy>).
4. That _____ (*Name of the Bidder/Firm*) hereby accepts the OIL's Banning Policy, without any demur, protest, reservations and agree to be bound by the said Policy.
5. That _____ (*Name of the Bidder/Firm*) hereby agrees that in the event of Bidder/Firm is banned under the OIL's *Banning Policy* then in such case the banning order shall also be applicable upon its *allied concern(s), partner(s) or associate(s) or director(s) or proprietor(s) involved in any capacity*.

(Bidder / Authorized signatory of Bidder)

Seal:

Date:

Place:

PROFORMA - U

PROFORMA FOR UNDERTAKING FROM THIRD PARTY INSPECTION AGENCY

(IF APPLICABLE)

(to be submitted on official letter head)

To

**The Head of Department,
Materials Department - Field Head Quarters (FHQ),
Oil India Limited, Duliajan P.O.,
Dibrugarh District, Assam, India - 786602**

Sir,

Sub: OIL's Tender Number _____

M/s. _____ having
registered office at _____
_____ intend
to participate in the above referred tender of M/s. Oil India Limited.

The tender conditions stipulates that the bidder shall submit documents pertaining to Bid Evaluation Criteria (BEC), duly verified and certified by designated independent Third-Party Inspection Agency.

In this regard this is to certify that copies of documents pertaining to Bid Evaluation Criteria (BEC)/Bid Rejection Criteria (BRC) submitted to us by the bidder have been verified and certified by us with originals and found to be genuine and authentic. We have signed and stamped on the copies of all the verified and certified documents having ____ nos. pages.

Note:

In the event of any requirement, OIL reserves the right to ask the inspection agencies to verify the documents with source, if required at no extra cost to OIL.

Thanking you,

Name & Signature of Authorized signatory :
Designation :
Phone No. :
Place :
Date :
Seal / Stamp :

ANNEXURES

ANNEXURE - I

PRICE BREAK UP FORMAT

A) PRICE BREAK UP OF ITEMS WHOSE COST IS TO BE INCLUDED IN “GEM PRICE SCHEDULE”.

Item Details	Unit Price (In Rs) including GST	Applicable GST rate considered in quoted unit price
<p>THIS IS A SPECIMEN PRICE BREAK-UP FORMAT FOR REFERENCE ONLY</p> <p>(NOTE: BIDDER SHOULD NOT UPLOAD THIS PRICE BID IN TECHNICAL BID DOCUMENT SUBMISSION AREA UNLESS OR OTHERWISE MENTIONED IN TENDER, FAILING WHICH BID WILL BE LIABLE FOR REJECTION)</p>		

B) PRICE BREAK UP OF ITEMS WHOSE COST IS NOT TO BE INCLUDED IN “GEM PRICE SCHEDULE”.

Sl. No.	Description	Qty	Unit Price (In Rs) including GST	Applicable GST rate

Notes:

- Price break-up to be provided as above, if asked for specifically in the tender.**
- Bidders should fill up, sign and upload this price break up under “Financial documents” of GEM Priced bid only. The price breakup should not be uploaded under GEM Technical bid as it shall lead to rejection of the bid.**

ANNEXURE-II

TECHNICAL & COMMERCIAL CHECKLIST

A. TECHNICAL CHECKLIST:

Sl. NO.	DESCRIPTION	BIDDER'S RESPONSE (COMPLIED / NOT COMPLIED/ NOT APPLICABLE)	REMARKS
(A)	<u>TECHNICAL</u>		
1)	Please categorically confirm whether the offered item / specification is same as mentioned in the tender specification?		
2)	Is your offer item/specification will be manufactured & tested as per relevant API norms as specified in the Tender (IF APPLICABLE)?		
3)	Have you supplied the item to any oil and gas industry? (If yes, please mention the details of client(s) to whom the item was supplied)		
4)	Have you submitted the API license (if applicable) valid till the execution of the Purchase Order?		
5)	Have you submitted all the supporting documents related to past supply experience requirement mentioned in tender?		
6)	If the bidder is a sole selling agent / distributor / dealer of the manufacturer of the tendered item(s), have you submitted the authorization certificate from the manufacturer (in original on manufacturer's letter head) along with the technical bid?		
7)	Items should be manufactured & tested strictly as per technical specification indicated in the tender without any deviation . Bidder to categorically confirm the same in their technical bid.		
8)	Quotation must be accompanied with relevant product catalogue / drawing, showing dimensional details, bill of material of various parts etc. (where applicable) of all components without which the offer will be liable for rejection.		

(SIGNATURE WITH COMPANY SEAL/STAMP)

ANNEXURE-II

TECHNICAL & COMMERCIAL CHECKLIST

B. COMMERCIAL CHECKLIST:

Sl. No.	Requirement	Bidder's Response (Complied / Not complied/ Not applicable)
1	Whether quoted as manufacturer?	
2	Whether quoted as OEM Dealer/Supply House?	
3	If quoted as OEM Dealer/Supply House -	
	a) Whether submitted valid and proper authorization letter from manufacturer confirming that bidder is their authorized Dealer/supply House for the product offered?	
	(b) Whether manufacturer's back-up Warranty/Guarantee certificate submitted?	
4	Whether agreed to the tender warranty clause of the tender?	
5.0	Whether submitted EMD/Bid Security / Bid Security Declaration as per tender requirement?	
5.1	EMD/Bid Security (Amount & Validity)	
5.2	EMD/Bid Security exemption certificate with Validity	
5.3	Whether submitted Bid Security Declaration as per Proforma-G(B) ?	
6	Whether quoted a firm delivery period as per the tender requirement?	
7	Whether confirmed to submit PBG as asked for in tender?	
8	Whether confirmed Bid Validity as per the tender requirement?	
9	Whether confirmed Payment Terms as per the tender?	
10	Whether quoted as MSE unit? If yes, whether necessary document submitted?	
11	Whether submitted Integrity Pact duly signed and sealed as per PROFORMA - D? (If applicable as per the tender)	
12	Whether indicated the country of origin for the items quoted? Please mention the "Country of origin" under Remarks here.	
13	Whether submitted format of undertaking by bidders towards submission of authentic information/ documents as per PROFORMA - H	
14	Whether submitted Proforma - J - Format for Exception / Deviation	

(SIGNATURE WITH COMPANY SEAL/STAMP)

ANNEXURE-II

TECHNICAL & COMMERCIAL CHECKLIST

B. COMMERCIAL CHECKLIST:

Sl. No.	Requirement	Bidder's Response (Complied / Not complied/ Not applicable)
15	<p>Ministry of Finance of Govt. of India, Department of Expenditure, Public procurement Division vide office memorandum F. No. 6/18/2019-PPD dated 23rd July, 2020(order-Public Procurement no.1) has proclaimed the insertion of Rule 144 (xi) in the General Financial Rules (GFRs), 2017 w.e.f. 23rd July, 2020 regarding restrictions on procurement from a bidder of a country which shares a land border with India on the grounds of defence of India on matters directly or indirectly related thereto including national security. Bidders are requested to take note of the office memorandum and submit their offers accordingly, wherever applicable.</p> <p>In this regard, bidders must submit duly sealed & signed undertaking as per format provided vide, PROFORMA – E(I), E(II) & E(III) along with the technical bid. Whether uploaded along with the bid?</p>	
16	<p>Whether indicated 'Local Content' required as per PPP-MII Policy?</p> <p>Local content amount and percentage. Details of locations at which the local value addition is made.</p>	
17	Whether indicated the import content in Price Bid?	
18	Whether all documents have been submitted as required for fulfilling Experience criteria clause of BRC-Technical (If Applicable).	
19	Name and details of the company to whom the bidder has successfully executed orders / contracts for atleast 50% of the tendered quantity as per Experience criteria clause of BRC-Technical (If Applicable).	
20	Whether submitted the profile and other documents of the company for verification (viz. Annual reports, Memorandum of Association, Article of Association etc.)	
21	Name of Manufacturer	
22	Place of Dispatch	
23	Name, Address, Phone No & E-mail ID of Bidder	
24	Bank details of Bidder	
25	Whether submitted Proforma – K - Format for Undertaking for Local Content	
26	Whether submitted Proforma-L - Format for Power of Attorney / Authorization letter (Regarding authority for submission of bid)	

(SIGNATURE WITH COMPANY SEAL/STAMP)

ANNEXURE-II

TECHNICAL & COMMERCIAL CHECKLIST

B. COMMERCIAL CHECKLIST:

Sl. No.	Requirement	Bidder's Response (Complied / Not complied/ Not applicable)
27	Whether submitted Proforma-M - Format for Bidders financial standing	
28	Whether submitted Proforma-N - Format for declaration of Blacklisting / Holiday Listing/ NCLT / NCLAT /DRT /DRAT/ Court Receivership/ Liquidation	
29	Whether submitted Proforma - O - Format for Bidder's Information	
30	Whether submitted Proforma - G(B) - Format for Bid Security Declaration (If Applicable)	
31	Whether submitted Proforma - Q - Format for Authorization & Backup Warranty by Manufacturers to sole selling agent / Dealer / Distributor?	
32	Whether submitted Proforma - C - Format for Corporate Guarantee towards financial standing?	
33	Whether submitted Proforma - T - Format for Undertaking on Acceptance of OIL's 'Banning Policy'?	
34	Whether submitted Proforma - U - Format for Undertaking from Third Party Inspection Agency (If applicable)?	
35	Whether submitted Proforma - S - Format for Sustainable Development (SD) and Environment Social and Governance (ESG) policy post order Questionnaire to vendors & suppliers (If applicable)?	

ANNEXURE – III

GENERAL CONDITIONS OF CONTRACT (GCC)

- 1.0 The bid is governed by GeM General terms & conditions (GeM GTC) prevalent on the bid closing date of tender.

PART-A) - SPECIAL CONDITIONS OF CONTRACT (SCC)

The SPECIAL CONDITIONS OF CONTRACT (SCC) shall supersede the GeM General terms & conditions (GeM GTC).

- 1.0** Bidders shall submit their offer mentioning pointwise compliance/noncompliance to all the terms & conditions, BEC/BRC, Specifications etc. Any deviation(s) from the tender terms & conditions, BEC/BRC, Specifications etc. should be clearly highlighted specifying justification in support of deviation.
- 2.0** To ascertain the substantial responsiveness of the bid, OIL reserves the right to ask the bidder for clarification in respect of clauses covered under BRC also and such clarifications fulfilling the BRC clauses in toto must be received on or before the deadline given by OIL, failing which the offer will be summarily rejected. However, bidder(s) must note that there should not be any additional financial involvement arising out of such post tender clarifications.
- 3.0** The Bidder to submit following Technical Evaluation Sheet along with technical bid -

Annexure – VI: Bid Evaluation Matrix (Technical Specification)

Annexure – VII: Bid Evaluation Matrix (Special Conditions of Contract-Part-B)

Annexure – VIII: Bid Evaluation Matrix (Bid Rejection Criteria)

4.0 INTEGRITY PACT (IF APPLICABLE)

OIL shall be entering into an Integrity Pact, **if applicable** with the bidders as per format enclosed vide **PROFORMA - D** of the tender document. This Integrity Pact proforma has been duly signed digitally by OIL's competent signatory. The proforma has to be returned by the bidder (along with the technical bid) duly signed (digitally) by the same signatory who signed the bid, i.e., who is duly authorized to sign the bid. Uploading the Integrity Pact with digital signature will be construed that all pages of the Integrity Pact have been signed by the bidder's authorized signatory who sign the Bid. If any bidder refuses to sign Integrity Pact or declines to submit Integrity Pact with the offer, their bid shall be rejected straightway.

OIL's Independent External Monitors at present are as under:

<p>Dr. Tejendra Mohan Bhasin, Former Vigilance Commissioner, CVC E-mail: tmbhasin@gmail.com</p>	<p>Shri.Ram Phal Pawar, IPS (Retd.), Former Director, NCRB, MHA E-mail: rpawar61@hotmail.com ramphal.pawar@ips.gov.in</p>	<p>Shri.Ajit Mohan Sharan, IAS (Retd.) Former Secretary, Ministry of Ayush, Govt. of India E-mail: ams057@gmail.com</p>
---	---	---

- 4.1** In case of a joint venture, all the partners of the joint venture should sign the Integrity Pact.

4.2 In the event of any dispute between the management and the contractor relating to those contracts where Integrity Pact is applicable, in case, both the parties are agreeable, they may try to settle dispute through mediation before the panel of IEMs in a time bound manner. If required, the organizations may adopt any mediation rules for this purpose. In case, the dispute remains unresolved even after mediation by the panel of IEMs, the organisation may take further action as per the terms and conditions of the contract.

5.0 MICRO AND SMALL ENTERPRISES (MSE)

Categorisation and various Criteria applicable to MSE bidders shall be guided by the Gazette Notification No. CG-DL-E-21032025-261838 Dated 21.03.2025 to be read with CG-DL-E-26062020-220191 dated 26.06.2020 and Amendment vide Gazette Notification no. CG-DL-E-16062021-227649 dated 16th June, 2021 issued by Ministry of Micro, Small and Medium Enterprises.

The bidder claiming as MSE status (MSE-General, MSE-SCIST, MSE -Woman) against this tender has to submit the following documents for availing the benefits applicable to MSEs:

Udyam Registration Number with Udyam Registration Certificate.

Note:

In case bidding MSE is owned by Schedule Caste or Schedule Tribe entrepreneur or Woman Entrepreneur, valid documentary evidence issued by the agency who has registered the bidder as MSE owned by SC/ST entrepreneur/ Woman Entrepreneurs should also be enclosed.

5.1 For availing benefits under Public Procurement Policy (Purchase preference), the interested MSE Bidders must ensure that they are the manufacturer of tendered item (Primary Product Category) and registered with the appropriate authority for the said item(s).

6.0 PREFERENCE TO MAKE IN INDIA (MII)

Department for Promotion of Industry and Internal Trade (DPIIT) has issued the revised 'Public Procurement (Preference to Make in India), Order 2017" vide Order no. No. P-45021/2/2017-PP (BE-II) dated 04.06.2020 and as amended from time to time. Bidders are requested to go through the policy at department's official website (www.dpiit.gov.in) and its subsequent amendments, if any, and take note of the same while submitting their offer.

7.0 DOMESTICALLY MANUFACTURED IRON & STEEL PRODUCTS (DMI & SP):

Revised Domestically Manufactured Iron & Steel Products Policy-2025 (DMI&SP Policy 2025) as notified vide Gazette Notification No.: CG-DL-E-26052025-263378 Date: 26/05/2025, Government of India, Ministry of Steel's OM:8(2)/2023-ID-1 (E-16515) Date: 17/06/2025 and as amended from time to time by Ministry of Steel, Government of India is applicable against this tender. The detailed policy may be referred in Ministry of Steel's website (www.steel.gov.in). Also, please refer **ANNEXURE – IV** to this tender in this regard.

8.0 RESTRICTIONS ON PROCUREMENT FROM A BIDDER OF A COUNTRY SHARING LAND BORDER WITH INDIA:

Ministry of Finance of Govt. of India, Department of Expenditure, Public procurement Division vide office memorandum F. No. 6/18/2019-PPD dated 23rd July, 2020 (order-Public Procurement no.1) has proclaimed the insertion of Rule 144 (xi) in the General Financial Rules (GFRs), 2017 w.e.f. 23rd July, 2020 and amended vide O.M. No. F.7/10/2021-PPD (1) dated 23.02.2023 (order public procurement no. 4) from Procurement Policy Division, Department of Expenditure, Ministry of Finance forwarded by Department of Public Enterprises vide O.M. No. F. No. DPE/7 (4)/2017-Fin dated 24.02.2023 regarding restrictions on procurement from a bidder of a country which shares a land border with India on the grounds of defence of India on matters directly or indirectly related thereto including national security. Bidders are requested to take note of the following clauses and submit their offers accordingly wherever applicable.

- (1)** Any bidder from a country which shares a land border with India will be eligible to bid in this tender only if the bidder is registered with the Competent Authority [Registration Committee constituted by the Department for Promotion of Industry and Internal Trade (DPIIT)]. Further, any bidder (including bidder from India) having specified Transfer of Technology (ToT) arrangement with an entity from a country which shares a land border with India, shall also require to be registered with the same competent authority to be eligible to bid in this tender.
- (2)** "Bidder" (including the term 'tenderer', 'consultant' or 'service provider' in certain contexts) means any person or firm or company, including any member of a consortium or joint venture (that is an association of several persons, or firms or companies), every artificial juridical person not falling in any of the descriptions of bidders stated hereinbefore, including any agency branch or office controlled by such person, participating in a procurement process.
- (3)** "Bidder (or entity) from a country which shares a land border with India" for the purpose of this Order means:
 - a.** An entity incorporated, established or registered in such a country; or
 - b.** A subsidiary of an entity incorporated, established or registered in such a country; or
 - c.** An entity substantially controlled through entities incorporated, established or registered in such a country; or
 - d.** An entity whose beneficial owner is situated in such a country; or
 - e.** An Indian (or other) agent of such an entity; or
 - f.** A natural person who is a citizen of such a country; or
 - g.** A consortium or joint venture where any member of the consortium or joint venture falls under any of the above
- (4)** The beneficial owner for the purpose of para (3) above will be as under:
 - (i)** In case of a company or Limited Liability Partnership, the beneficial owner is the natural person(s), who, whether acting alone or together, or through one or more juridical person, has a controlling ownership interest or who exercises control through other means.

Explanation:

- a. "Controlling ownership interest" means ownership of or entitlement to more than twenty-five percent of shares or capital or profits of the company.
- b. "Control" shall include the right to appoint majority of the directors or to control the management or policy decisions including by virtue of their shareholding or management rights or shareholder's agreements or voting agreements.
- (ii) In case of a partnership firm, the beneficial owner is the natural person(s) who, whether acting alone or together, or through one or more juridical person, has ownership of entitlement to more than fifteen percent of capital or profits of the partnership;
- (iii) In case of an unincorporated association or body of individuals, the beneficial owner is the natural person(s), who, whether acting alone or together, or through one or more juridical person, has ownership of or entitlement to more than fifteen percent of the property or capital or profits of such association or body of individuals;
- (iv) Where no natural person is identified under (i) or (ii) or (iii) above, the beneficial owner is the relevant natural person who holds the position of senior managing official;
- (v) In case of a trust, the identification of beneficial owner(s) shall include identification of the author of the trust, the trustee, the beneficiaries with fifteen percent or more interest in the trust and any other natural person exercising ultimate effective control over the trust through a chain of control or ownership.
- (5) An Agent is a person employed to do any act for another, or to represent another in dealings with third person.
- (6) The successful bidder shall not be allowed to sub-contract works to any contractor from a country which shares a land border with India unless such contractor is registered with the Competent Authority.

(7) **Validity of Registration:**

The registration should be valid at the time of submission of bid and at the time of acceptance of bid. If the bidder was validly registered at the time of acceptance/placement of order, registration shall not be a relevant consideration during contract execution.

(8) **Undertaking regarding compliance:**

The bidders are required to provide undertakings as per **PROFORMA – E(I), PROFORMA – E(II) & PROFORMA – E(III)** along with their bid towards compliance of the above guidelines for participation in this tender. If the undertakings given by a bidder whose bid is accepted is found to be false, this would be a ground for debarment/action as per OIL's Banning Policy and further legal action in accordance with law.

9.0 SETTLEMENT OF COMMERCIAL DISPUTES BETWEEN CENTRAL PUBLIC ENTERPRISES (CPSES) INTER-SE AND CPSE(S) AND GOVERNMENT DEPARTMENT(S)/ORGANISATIONS(S) - ADMINISTRATIVE MECHANISM FOR RESOLUTION OF CPSES DISPUTES (AMRCD).

In the event of any dispute or difference relating to the interpretation and application of the provisions of commercial contract(s) between Central Public Sector Enterprises (CPSEs) / Port Trusts inter se and also between CPSEs and Government Department/Organisations (excluding disputes relating to Railways, Income Tax, Customs and Excise Departments), such dispute or difference shall be taken up by either party for its resolution through AMRCD as mentioned in DPE OM No. 05/003/2019-FTS- 10937 dated 14th December, 2022 and the decision of AMRCD on the said dispute will be binding on both the parties.

10.0 TAX COLLECTIBLE AT SOURCE (TCS):

Tax Collectible at Source (TCS) applicable under the Income-tax Law and charged by the SUPPLIER shall also be payable by OIL along with consideration for procurement of goods/materials/ equipment. If TCS is collected by the SUPPLIER, a TCS certificate in prescribed Form shall be issued by the SUPPLIER to OIL within the statutory time limit.

Payment towards applicable TCS u/s 206C (IH) of Income Tax Act, 1961 will be made to the supplier provided they are claiming it in their invoice and on submission of following undertaking along with the invoice stating that:

- a. TCS is applicable on supply of goods invoiced to OIL as turnover of the supplier in previous year was more than Rs. 10 Cr. And
- b. Total supply of goods to OIL in FY (As applicable) exceeds Rs. 50 Lakh and
- c. TCS as charged in the invoice has already been deposited (duly indicating the details such as challan No. and date) or would be deposited with Exchequer on or before the due date and
- d. TCS certificate as provided in the Income Tax Act will be issued to OIL in time.

However, Performance Security deposit will be released only after the TCS certificate for the amount of tax collected is provided to OIL. Supplier will extend the performance bank guarantee (PBG), wherever required, till the receipt of TCS certificate or else the same will be forfeited to the extent of amount of TCS, if all other conditions of Purchase order are fulfilled.

The above payment condition is applicable only for release of TCS amount charged by supplier u/s 206C (I H) of Income tax Act, 1961.

11.0 CONCESSIONAL GST (IF APPLICABLE)

The items covered in this Tender shall be used by Oil India Limited in the Petroleum Exploration License (PEL) and Mining Lease (ML) areas and hence concessional **GST @ 12%** will be applicable as per Govt. Policy in vogue. **Concessional GST @ 12% will be applicable only if total material value is more than Rs.1,00,000 (i.e. 1 Lakh & above). Otherwise, GST at actuals / merit rate will be reimbursed against submission of documentary evidence. Bidder is advised to take note of above and accordingly submit price bid.**

Important Notes:

- 1) Successful bidder shall arrange to provide all necessary information and documents (invoice etc.) to Oil India Limited for applying Indigenous Supplies Certificate (ISC) with DGH, Government of India to avail concessional GST benefit against order goods (if awarded), **at-least 60 days** before readiness for despatch and date of dispatch to obtain ISC from DGH. OIL will not be responsible for any delay in issuance of ISC & subsequent levy of Liquidated Damage (LD) charges, in case of delay in submission of proforma invoice, requisite information / documents to process ISC application with DGH by seller & delivery of goods as per purchase order (if awarded). Further, successful bidder shall effect dispatch only on receipt of relevant certificates/shipment clearance from OIL, failing which all related liabilities shall be to supplier's account.
- 2) Please note that Indigenous Supplies Certificate (ISC) issued by DGH will be valid for a period of six (06) months from the date of issuance of ISC and successful bidder / seller is advised to plan for delivery of order goods (if awarded) accordingly.
- 3) Wherever the delivery period is lesser than 60 days from date of award of purchase order, successful bidder shall arrange to provide all necessary information and documents (invoice etc.) to OIL to avail concessional GST benefit against order goods (if awarded) within five (05) days from the date of receipt of purchase order from seller to obtain ISC from DGH. OIL will not be responsible for any delay in issuance of ISC & subsequent levy of Liquidated Damage (LD) charges, in case of delay in submission of proforma invoice, requisite information / documents to process ISC application with DGH by seller & delivery of goods as per purchase order (if awarded).
- 4) In case of non-applicability of concessional GST benefit as mentioned in above paragraph, bidder is advised to indicate applicable merit rate of GST for offered good(s) in their bid. However, Oil India Limited / Buyer reserves the right to compile and combine / club requirement of concessional GST eligible tendered goods (as applicable) against various tenders (in case of total offered material value against individual tender is less than Rupees One Lakh (Rs. 1,00,000.00) during ordering stage to avail concessional GST benefits (wherever possible) and bidder / seller is abided by decision of Oil India limited / buyer in this regard.
- 5) Successful bidder/seller shall effect dispatch only on receipt of Indigenous Supplies Certificate (ISC) and other relevant certificates/shipment clearance from Oil India Limited (Buyer), failing which all related liabilities shall be to supplier's account.

12.0 APPLICABILITY OF BANNING POLICY OF OIL INDIA LIMITED:

OIL's Banning Policy, 2023 will be applicable against the tender (and order in case of award) to deal with any agency (bidder/contractor/supplier/ vendor/service provider) who commits deception, default, fraud or indulged in other misconduct of whatsoever nature in the tendering process and/or order execution processes.

The bidders who are on Holiday/Banning/Suspension list of OIL on due date of submission of bid/ during the process of evaluation of the bids, the offers of such bidders shall not be considered for bid opening/evaluation/award. If the bidding documents were issued inadvertently/downloaded from website, the offers submitted by such bidders shall also not be considered for bid opening/evaluation/ Award of Work.

12.1 The bidder shall submit an undertaking/declaration as per **PROFORMA- N** confirming that they have read and understood OIL's Banning Policy and that, neither they nor any of their allied concerns or partners or associates or directors, or proprietors involved in any capacity, are currently on OIL's Holiday/Banning List. Further, the bidder shall confirm that neither they nor any of their aforementioned entities have, during the last three years, been involved in any transgression with any company conforming to the Transparency International (TI) approach or with any Public Sector Enterprise of India that could justify exclusion from the tender process. The bidder shall also disclose details of all such allied entities, if any, as required under the Banning Policy. The bidder shall fill up and submit proforma of declaration of **Blacklisting / Holiday Listing/ NCLT / NCLAT /DRT /DRAT/ COURT RECEIVERSHIP/ LIQUIDATION** (as per **Proforma- N**) along with the technical bid).

12.2 The bidder shall fill up and submit proforma of **Undertaking on Acceptance of OIL's 'Banning Policy'** (As per **Proforma- T**) along with the technical bid).

13.0 PERFORMANCE SECURITY

Successful bidder will be required to furnish a Performance Bank Guarantee @ **5%** of the order value with validity as mentioned in the tender document. The Performance Security must be submitted exactly as per **PROFORMA – F**. Bidder must confirm the same in their Technical Bid.

The Bank Guarantee issued by the bank must be routed through SFMS platform as per the following details:

- (i) MT 760/MT 760 COV for issuance of bank guarantee.
 - (ii) MT 760/MT 767 COV for amendment of bank guarantee.
- [Order Number should reflect in the SFMS text under MT 760/MT 760 COV]***

The above message/intimation shall be sent through SFMS by the BG issuing Bank branch to ICICI Bank, Duliajan Branch, IFSC Code- ICIC0000213, Branch Address.: ICICI Bank Ltd, Kunja Bhavan, Daily Bazaar, Duliajan, Dibrugarh, Assam - 786602. The Bank details are as under:

Bank Details of Beneficiary	
Bank Name	ICICI BANK LTD.
Branch Name	DULIAJAN
Branch Address	KUNJA BHAVAN, DAILY BAZAAR, DULIAJAN, DIBRUGARH, ASSAM - 786602
IFSC Code	ICIC0000213
Unique identifier code (Field 7037)	OIL503988890
Company name	Oil India Limited

The vendor shall submit to OIL the copy of the SFMS message as sent by the issuing bank branch along with the original bank guarantee.

13.1 Performance Security shall be issued from any scheduled Indian Bank or any branch of an International Bank situated in India and registered with the Reserve Bank of India as scheduled foreign Bank in case of domestic suppliers.

- 13.2** Bank Guarantees issued by a Bank in India should be on non-judicial Stamp Paper/Franking receipt of requisite value, as per Indian Stamp Act, purchased in the name of the Banker or the Seller.
- 13.3** Bank Guarantee with condition other than those mentioned in OIL's prescribed format shall not be accepted.
- 13.4** The Bank Guarantee issued by a Bank amongst others shall contain the complete address of the Bank including Phone Nos., Fax Nos., E-mail address, Code Nos. of the authorized signatory with full name and designation and Branch Code.
- 13.5** The Performance Security shall be payable to Purchaser as compensation for any breach or loss resulting from Supplier's failure to fulfil its obligations under the Purchase Order/Contract. In the event of such default on the part of Seller, the Performance Security shall be encashed unconditionally, and the proceeds thereof shall be forfeited without any further reference to the Seller. In such an eventuality, the Seller shall be liable to face penal actions including debarment as per OIL's Banning Policy, 2023.
- 13.6** The Performance Security shall be discharged by Purchaser not later than 30 days following its expiry after completion of obligations under the order/contract. In the event of any extension to the contractual validity or delay in supply/ execution or extension of Warranty Period of the Purchase Order/Contract, validity of the Performance Security shall be extended by the Seller/Contractor by the equivalent period.
- 13.7** The Performance Security shall not accrue any interest during its period of validity or extended validity. OIL shall not be liable to pay any bank charges, commission or interest on the amount of Performance Security.
- 13.8** Failure of the successful Bidder to comply with the requirements of above clauses shall constitute sufficient grounds for annulment of the award and forfeiture of their Bid Security or Performance Security. The defaulting party shall also be debarred from business as per OIL's Banning Policy, 2023.
- 13.9** In case, the Performance Security in the form of a Bank Guarantee is found to be not genuine or issued by a fake banker or issued under the fake signatures, the Purchase Order placed on the bidder shall be treated as cancelled forthwith and the bidder shall be banned from participating in future tenders in accordance with the provisions of Company's Banning Policy, 2023. Further, the Bid Security submitted by such bidder shall be invoked without any further reference, besides other penal action, as the Company may think appropriate.
- 13.10** In case Annual Maintenance Contract (AMC) is required and OIL intends to enter into a separate contract with the successful bidder for AMC, the Successful bidder must undertake to submit separate Performance Security against the AMC at the applicable rate & validity to be stipulated in the contract. (10% of annualized contract value valid for three months beyond entire execution period).

14.0 BID SECURITY (IF APPLICABLE):

If Bid Security /Earnest Money Deposit (EMD) is applicable, bids must be accompanied by Bid Security for the amount as mentioned in the tender and shall be in the prescribed format (**PROFORMA – G(A)**) as Bank Guarantee (BG) or Online payment. (Refer GeM GTC for details).

In case of the Bid Security is submitted in the form of Bank Guarantee, scanned copy of Bank Guarantee shall be uploaded by the bidder in the online bid and **Original Bank Guarantee will have to be submitted directly to OIL on or before the Bid closing date and time, failing which the bid may be treated as incomplete and may lead to rejection of the bid by OIL without making any reference to the bidder.**

The Original Bid Security shall be submitted manually in sealed envelope **superscribed** with tender no., tendered item detail and due date to: **GM-MATERIALS, MATERIALS DEPARTMENT, KIND ATTENTION – Mr. F.SATHIYARAJ, SENIOR MANAGER-MATERIALS, MATERIALS DEPARTMENT, FOREIGN PURCHASE SECTION, OIL INDIA LIMITED, DULIAJAN P.O., DIBRUGARH DIST., ASSAM, INDIA -786602.**

In case of Online payment of Bid Security, bidder shall provide the Online transaction details in their online bid as proof of submission of Bid Security to OIL. The online payment of Bid Security amount should be received in OIL's bank account on or before the Bid closing date and time failing which the offer will be rejected outright without any further reference.

OIL's Bank account Details for Online submission of Bid Security	
Name	Oil India Limited
Bank	State Bank of India
Branch	Duliajan
Account Number	10494832599
Account Type	Current
IFSC Code	SBIN0002053

- 14.1** Bid Security shall be issued from any scheduled Indian Bank or any branch of an International Bank situated in India and registered with the Reserve Bank of India as scheduled foreign Bank in case of domestic suppliers.
- 14.2** Bank Guarantee issued by a scheduled Bank in India at the request of some other non-scheduled Bank in India shall not be accepted.
- 14.3** Bank Guarantees issued by a Bank in India should be on non-judicial Stamp Paper/Frinking receipt of requisite value, as per Indian Stamp Act, purchased in the name of the Banker or the Seller.
- 14.4** Bank Guarantee with condition other than those mentioned in OIL's prescribed format/GeM Bank Guarantee format shall not be accepted.
- 14.5** The Bank Guarantee issued by a Bank amongst others shall contain the complete address of the Bank including Phone Nos., Fax Nos., E-mail address, Code Nos. of the authorized signatory with full name and designation and Branch Code.
- 14.6** The bidders will extend the validity of the Bid Security, if and whenever specifically advised by OIL, at the bidder's cost.
- 14.7** The Bid Security shall not accrue any interest during its period of validity or extended validity. OIL shall not be liable to pay any bank charges, commission or interest on the amount of Bid Security.

14.8 In case, the Bid Security in the form of a Bank Guarantee is found to be not genuine or issued by a fake banker or issued under the fake signatures, the bid submitted by the concerned bidder shall be rejected and the bidder shall be banned from participating in future tenders in accordance with the provisions of OIL's Banning Policy. Further, the Bid Security submitted by such bidder shall be invoked without any further reference, besides other penal action, as OIL may think appropriate.

14.9 In case of Bank Guarantee, the Bank Guarantee issuing bank branch must ensure the following:

The Bank Guarantee issued by the bank must be routed through SFMS platform as per the following details:

- (i) MT 760/MT 760 COV for issuance of bank guarantee.
- (ii) MT 760/MT 767 COV for amendment of bank guarantee.

[Tender Number should reflect in the SFMS text under MT 760/MT 760 COV]

The above message/intimation shall be sent through SFMS by the BG issuing Bank branch to ICICI Bank, Duliajan Branch, IFSC Code- ICIC0000213, Branch Address: ICICI Bank Ltd, Kunja Bhavan, Daily Bazaar, Duliajan, Dibrugarh, Assam – 786602. The Bank details are as under:

Bank Details of Beneficiary	
Bank Name	ICICI BANK LTD.
Branch Name	DULIAJAN
Branch Address	KUNJA BHAVAN, DAILY BAZAAR, DULIAJAN, DIBRUGARH, ASSAM – 786602
IFSC Code	ICIC0000213
Unique identifier code (Field 7037)	OIL503988890
Company name	Oil India Limited

The bidder shall submit to OIL the copy of the SFMS message as sent by the issuing bank branch along with the original bank guarantee.

14.10 The Bid Security of the unsuccessful bidders will be returned after finalization of tender whereas the Bid Security of the successful bidder will be discharged on such bidder's furnishing the Performance Security to OIL against the Purchase Order secured by the bidder within the stipulated time frame. The successful bidder will, however, extend validity of the Bid Security till such time the Performance Security is furnished.

14.11 For timely return of Bid Security, **bidders shall submit following details along with their technical bid.**

- For Bank Guarantee (BG): Name, Email id, Phone number and Address where the Bid Security is to be returned by Courier.
- Online payment: Name, Email id, Phone number and Bank details (Bank Name, Branch Name, Branch Address, IFSC Code, Unique Identifier Code, Company name) where the Bid Security amount shall be returned by Online transfer.



TO BE SUBMITTED BY BIDDER'S LETTER HEAD ALONG WITH TECHNICAL BID

Disclaimer :

In case of non-submission of below requisite details, return of Bid Security may be delayed.

Return of Bid Security / EMD as Bank Guarantee (BG)

Sl. No.	Term	:	Value
1)	Name	:	
2)	Email Address	:	
3)	Telephone / Mobile Number	:	
4)	Address	:	

Return of Bid Security / EMD through Electronic Transfer (RTGS/NEFT/IMPS)

Sl. No.	Term	:	Value
1)	Name	:	
2)	Email Address	:	
3)	Telephone / Mobile Number	:	
4)	Address	:	
5)	Bank Name	:	
6)	Branch Name	:	
7)	Branch Address	:	
8)	IFSC Code	:	
9)	Unique Identifier Code	:	
10)	Bidder's Company name	:	

14.12 If Bid Security /Earnest Money Deposit (EMD) is not applicable. Instead of EMD /Bid Security, all the bidders shall be required to sign a “Bid Security Declaration” accepting that if they withdraw or modify their Bids during the period of validity, or if they are awarded the contract and they fail to sign the contract, or to submit a performance security before the deadline defined in the NIT/ Purchase order, they shall be suspended for the period of 2 (two) years. This suspension of two years shall be automatic without conducting any enquiry. Bidders shall submit “Bid Securing Declaration” as per enclosed PROFORMA - GB along with their technical bids.

14.13 Submission of Bid Security and Performance Security in the form of Electronic Bank Guarantee (e-BG)

Oil India Ltd. has now adopted Electronic Bank Guarantee (e-BG) for Bid Security and Performance Security in addition to the existing provisions. Electronic Bank Guarantee (e-BG) is a digitally signed BG issued by banks which is transmitted directly from banks to beneficiaries in electronic form through a platform provided by National E-Governance Services Limited (NeSL).

Submission of Bid Security/Performance Security, as applicable, in the form of Electronic Bank Guarantee (e-BG) is also acceptable:

Sl. No.	Bank name	Sl. No.	Bank name
1	AU Small Finance Bank	18	Indian Bank
2	Axis Bank	19	Indian Overseas Bank
3	Bank of Baroda	20	IndusInd Bank
4	Bank of India	21	Karnataka Bank
5	Bank of Maharashtra	22	Karur Vysya Bank
6	Canara Bank	23	Kotak Mahindra Bank
7	Central Bank of India	24	Punjab & Sind Bank
8	City Union Bank	25	Punjab National Bank
9	DBS Bank	26	RBL Bank
10	DCB Bank	27	Standard Chartered
11	Dhanlaxmi Bank	28	State Bank of India
12	Federal Bank	29	South Indian Bank
13	HDFC Bank	30	Tamilnad Mercantile Bank
14	HSBC Bank	31	UCO Bank
15	ICICI Bank	32	Union Bank of India
16	IDBI Bank	33	Yes Bank
17	IDFC First Bank		

Beneficiary details for issue of e-BG are:

Sl. No.	Particulars	Details
1)	Name	Oil India Limited
2)	PAN	AAACO2352C
3)	Date of Incorporation	18-02-1959
4)	Email ID	bg_sfms@oilindia.in
5)	Mobile No.	+91-374-2806182 +91-9434339797 +91-8429402705
6)	Local Address	Oil India Limited, Materials Department, Field Head Quarters, Duliajan P.O., Dibrugarh District, Assam, India, Postal Code - 786602
7)	Registered Address	Duliajan, Dibrugarh, Assam-786602

15.0 FINANCING OF TRADE RECEIVABLES OF MICRO AND SMALL ENTERPRISES (MSEs) THROUGH TRADE RECEIVABLES DISCOUNTING SYSTEM (TREDS) PLATFORM:

Based on the initiatives of Government of India to help MSE vendors get immediate access to liquid fund based on Buyers credit rating by discounting, OIL has registered itself on TReDS platform with M/s RXIL and M/s A TReDS Ltd. (Invoice Mart). MSE vendors can avail this benefit by registering themselves with any of the exchanges providing e-discounting/electronic factoring services on TReDS platform and following the procedures defined therein, provided OIL is also participating in such TReDS Platform as a Buyer.

- i) MSE Vendor should be aware that all costs relating to availing the facility of discounting on TReDS platform including but not limited to Registration charges, Transaction charges for financing, Discounting Charges, Interest on financing, or any other charges known by any name shall be borne by MSE Vendor.
- ii) MSE Vendor hereby agrees to indemnify, hold harmless and keep OIL and its affiliates, Directors, officers, representatives, agents and employees indemnified, from any and all damages, losses, claims and liabilities (including legal costs) which may arise from Sellers submission, posting or display, participation, in any manner, on the TReDS Platform or from the use of Services or from the Buyer's breach of any of the terms and conditions of the Usage Terms or of this Agreement and any Applicable Law on a full indemnity basis.
- iii) OIL shall not be liable for any special, indirect, punitive, incidental, or consequential damages or any damages whatsoever (including but not limited to damages for loss of profits or savings, business interruption, loss of information), whether in contract, tort, equity or otherwise or any other damages resulting from using TReDS platform for discounting their (MSE Vendor's) invoices.

Note:

- (i) Buyer means OIL who has placed Purchase Order/ Contract on a MSE Vendor (Seller).
- (ii) Seller means a MSE vendor, who has been awarded Purchase Order/ Contract by OIL (Buyer).

16.0 UNLOADING FOR BULKY/HEAVY ITEMS:

All the Goods in the GeM shall be offered on Free Delivery at Site basis including unloading. **HOWEVER, OIL SHALL PROVIDE CRANE FOR UNLOADING OF BULKY/HEAVY ITEMS ONLY.** Supplier shall depute adequate crew, who has experience of unloading of such items at Destination (Duliajan) with necessary safety gears i.e. helmet, safety boots, hand gloves etc. at unloading point.

The safety of the crew deputed by the supplier shall entirely be the responsibility of supplier and therefore they shall take all necessary measures/precautions to ensure that no injuries occur to personnel or property. Supplier must ensure that the crew involved for unloading are properly trained on the procedures and aware of the potential hazards while handling the items.

- 16.1** OIL reserves the right to divert any truck / trailer originally booked for a particular destination to nearby areas within a distance of 50 km from Duliajan.

17.0 UNLOADING OF TUBULARS:

All the Goods in the GeM shall be offered on Free Delivery at Site basis including unloading. **HOWEVER, OIL SHALL PROVIDE CRANE FOR UNLOADING OF TUBULARS ONLY.** Supplier shall depute adequate crew, who has experience of unloading of tubulars, at Destination (Duliajan) with necessary safety gears i.e. helmet, safety boots, hand gloves etc. at unloading point. **THE ONLY RESPONSIBILITY OF THE CREW TO BE DEPUTED BY THE SUPPLIER IS TO FASTEN/FIX CRANE'S HOOK SLING TO BUNDLES ON THE LOADED VEHICLE.** Once the hook sling is securely fastened complying to the safety instructions, OIL's Crane shall lift and unload tubulars from the vehicle. Following points are to be noted and complied in this connection:

- (a) Supplier to ensure that height of the loaded tubular is below the cabin height of the vehicle for safe off-loading.
- (b) Supplier to ensure that tubular bundles are securely fastened by very strong material to withstand the rigors of road transportation and capable of lifting by Crane. In the case tubular bundles are found loosened and/or tubulars found completely resting on the side support/bales of vehicle in way that it may free fall upon unshackling, OIL will not unload such vehicle due to safety reasons.

The safety of the crew deputed by the supplier shall entirely be the responsibility of supplier and therefore they shall take all necessary measures/precautions to ensure that no injuries occur to personnel or property. Supplier must ensure that the crew involved for unloading are properly trained on the procedures and aware of the potential hazards while handling tubulars.

- 17.1** OIL reserves the right to divert any truck / trailer originally booked for a particular destination to nearby areas within a distance of 50 km from Duliajan.

18.0 UNLOADING OF CONSIGNMENT RECEIVED THROUGH RAIL:

Unloading of consignment from Railway Wagons at Destination (**Duliajan**) shall be completely in OIL's scope.

19.0 QUANTITY TOLERANCE FOR TUBULARS (IF APPLICABLE):

Bidders should note that, in the event of order, quantity tolerance of +0%/-2% of order quantity will be applicable.

20.0 SET-OFF:

Any sum of money due and payable to the Seller (including Security Deposit refundable to them) under any purchase order may be appropriated by Oil India Limited and set-off against any claim of Oil India Limited (or such other person or persons contracting through Oil India Limited) for payment of a sum of money arising out of any other purchase order made by the Seller with Oil India Limited (or such other person or persons contracting through Oil India Limited).

21.0 FURNISHING FRAUDULENT INFORMATION/ DOCUMENT:

If it is found that a Bidder has furnished fraudulent document/information, the Bid Security/ Performance Security shall be forfeited and necessary action as per OIL's Banning Policy, 2023 shall be taken, besides the legal action. In this regard, bidders are requested to submit an Undertaking as per **PROFORMA - H** along with their offer failing which their offer shall be liable for rejection.

22.0 GENERAL CONDITIONS OF CONTRACT FOR SERVICES (ANNEXURE - V)

General Conditions of Contract for Services (GCC - SERVICES) shall be applicable for all services to be rendered including AMC (as and when entered into).

23.0 MODIFICATION/AMENDMENT OF TENDER DOCUMENT:

At any time prior to the deadline for submission of bids, the Company may, for any reason, whether at its own initiative or in response to a clarification requested by a prospective Bidder, modify the tender Documents through issuance of Corrigendum(s)/Addendum(s). Bidders are expected to take the Corrigendum(s)/ Addendum(s) into account in preparation and submission of their bid. No separate intimation for Corrigendum(s)/Addendum(s) published by OIL shall be sent to the Bidders.

24.0 THIRD PARTY INSPECTION (TPI) (IF APPLICABLE)

i) Third Party Inspection (TPI) will be under the scope of seller at seller's cost.

ii) All ordered goods shall be inspected by any one of OIL's approved Third-party inspection agencies (viz. M/S Lloyds or M/S Bureau Veritas or M/S RITES or M/S DNGL or M/S IRS or M/S Tuboscope Vecto only Third-party party inspection report shall be submitted along with supply of the materials.



- iii)** Supplier shall arrange for inspection (TPI) of the materials through OIL's approved Third-Party Inspection Agency at Bidder's/Manufacturer's plant/premises as per the broad Scope of Work mentioned in the tender. All cost towards the engagement of Third-Party Inspection Agency shall be borne by Supplier. **Bidder shall quote/include the cost of Third-Party Inspection in their offer.**
- iv)** At present, there are six OIL's empaneled Third-Party Inspection Agency as under:
- (1)** M/s. Lloyds
 - (2)** M/s. BureauVeritas
 - (3)** M/s. RITES
 - (4)** M/s. IR CLASS System and Solutions Private Limited
 - (5)** M/s. Tuboscope Vetco
 - (6)** M/s. DNV MES India Private Limited
- v)** Bidder shall clearly indicate in the technical bid the place/plant where Third-Party Inspection of the materials shall be conducted, in the event of an order.
- vi)** The bidder shall confirm that the Third-party inspection shall be covering the Scope of Inspection mentioned as part of the material specification / description.
- vii)** The bidder shall confirm that the bidder shall submit following documents (unless or otherwise specified in order / contract) along with material supply:
- (1)** OEM's Warranty / Guarantee certificate for performance at the specified operating conditions
 - (2)** Test certificates (As applicable) from the manufacturer
 - (3)** TPI reports
 - (4)** Certified copy of Mill Test Certificates for raw material
 - (5)** Heat treatment graph / certificate
 - (6)** Hydraulic Test Report
- viii)** The supplier shall provide, without any extra charge to OIL, all materials, tools, labour and assistance of every kind which the OIL nominated TPI Agency may demand for any test or examination required at supplier's premises. The supplier shall also provide and deliver sample from the material under inspection, free of charge, at any such place other than their premises as the TPI Agency may specify for acceptance tests for which the supplier does not have the facilities for such tests at their premises. In the event of testing outside owing to lack of test facility at supplier's premises, the supplier shall bear cost of such test, if any.
- ix)** The supplier shall not be entitled to object on any ground whatsoever to the method of testing adopted by the OIL nominated TPI Agency.
- x)** Unless otherwise provided for in the Purchase Order, the quantity of materials expended in test will be borne by supplier.
- xi)** The decision of the Third-Party Inspection Agency nominated by OIL regarding acceptance/rejection of material shall be final and binding on the supplier.

- xii)** Upon successful completion of the TPI and acceptance of the TPI reports by OIL, Bidder/Supplier shall be intimated by OIL for dispatch of the materials. The materials should be despatched only after receipt of dispatch clearance from OIL.
- xiii)** Acceptance of the TPI reports and receipt of dispatch intimation from OIL do not absolve the bidder from any warranty obligations or waive the bidder from OIL's right for rejection of the materials after receipt at site.
- xiv)** Notwithstanding clauses contained herein above, in the event the materials under inspection fails to conform to purchase order specification and are rejected by OIL nominated Third Party Inspection agency, OIL may recover all cost incurred for re-inspection of the materials from the supplier.

25.0 DOCUMENTATION (FOR DOMESTIC/INDIGENOUS SUPPLIERS):

- 25.1** Preparation and submission of proper documents by Seller is one of the very important requirements. The Seller must strictly follow the instructions.
- 25.2** Seller shall ensure that all the documents have clear reference of OIL's Purchase Order number.
- 25.3** Seller shall forward the documents, as mentioned below, by courier service immediately after the dispatch is made:

(I) WHERE PAYMENT AGAINST DIRECT SUBMISSION OF DESPATCH DOCUMENTS TO COMPANY:

A)	General Manager (A/P), Finance & Accounts Department Oil India Limited, Duliajan, PIN - 786602	i) Bill in original + one copy. ii) Copy of the C-Note/RR. iii) Copy of Mill Inspection Certificate, if any. iv) Copy of Third-Party Inspection Certificate, if any. v) Copy of Delivery Challan. vi) Copy of TPI Declaration vii) Copy of Tax Invoice. viii) Copy of packing list. ix) Documentary evidence of payment of Customs Duty, if any.
B)	GM - Materials (Receiving), Materials Department Oil India Limited, Duliajan, PIN - 786602	i) Clear Consignee copy of RR/C-Note - Original + 1 copy. ii) Copy of Tax Invoice. iii) Delivery Challan (Original). iv) Packing list (Original). v) Mill inspection certificate, if any (Original). vi) Copy of Third-Party Inspection certificate, if any. vii) Copy of TPI Declaration viii) Warranty Certificate (Original)
C)	Senior Manager - Materials (FP) Materials Department Oil India Limited, Duliajan, PIN - 786602	One set consisting copies of all the documents as mentioned in (B) above.

Note:

Where payment term is after receipt and acceptance of materials, the complete set of documents meant for General Manager (A/P) as indicated in (A) above should be submitted to Dy. General Manager Materials (Receiving).

27.0 FORCE MAJEURE:

- 27.1. In the event of either party being rendered unable by Force Majeure to perform any obligations required to be performed by them under the purchase order the relative obligations of the party affected by such force majeure shall upon notification to the other party be suspended for the period during which force majeure event lasts. The cost and loss sustained by the either party shall be borne by the respective parties.
- 27.2. The term force majeure as employed herein shall mean Acts of God such as earthquake, hurricane, typhoon, flood, volcanic activity etc.; war (declared /undeclared); riot, revolts, rebellion, terrorism, sabotage by persons other than the SELLER's Personnel; fires, explosions, ionizing radiation or contamination by radio-activity or noxious gas, if not caused by SELLER's fault; declared epidemic/pandemic or disaster; acts and regulations of respective Govt. of the two parties, namely the PURCHASER and the SELLER and civil commotions, lockout not attributable to the SELLER.
- 27.3. Upon occurrence of such cause(s) and upon its termination, the party alleging that it has been rendered unable as aforesaid thereby, shall notify the other party by a registered letter duly certified by the statutory authorities immediately but not later than 7(seven) days of the alleged beginning and ending thereof giving full particulars and satisfactory evidence in support of its claim.
- 27.4. Time for performance of the relative obligations suspended by the force majeure shall then be extended by the period for which such cause lasts. The extension of time shall be the sole remedy of the Seller for any delay under this clause and the Seller shall not be entitled in addition to or in lieu of such extension to claim any damages or compensation on any account whatsoever whether under the law governing contracts or any other law in force, and the Seller hereby waives and disclaims any and all contrary rights.
- 27.5. If the force majeure conditions persist for a period exceeding two (2) months, the Purchaser reserves the right to cancel the purchase order in full or in part.

28.0 SIGNING OF BIDS:

Bids are to be submitted online in GeM portal. The bid including all uploaded documents shall be signed by duly authorized representative of the bidder holding a Power of Attorney to bind the Bidder to the contract. The letter of authorization (**as per Proforma-L**) shall be indicated by written Power of Attorney accompanying the Bid.

29.0 BIDDERS FINANCIAL STANDING:

The bidder should not be under liquidation, court receivership or similar proceedings, should not be bankrupt. Bidder to upload undertaking (**as per Proforma-M**) to this effect with bid.

30.0 SETTLEMENT OF DISPUTES:

30.1. Arbitration (Applicable for Suppliers/CONTRACTORS other than PSU and MSME):

- 1) Except as otherwise provided elsewhere in the contract, if any dispute, difference, question or disagreement arises between the parties hereto or their respective representatives or assignees, in connection with construction, meaning, operation, effect, interpretation of the contract or breach thereof which parties are unable to settle mutually, the same shall be referred to Arbitration as provided hereunder:
- 2) A party wishing to commence arbitration proceeding shall invoke Arbitration Clause by giving 30 days' notice to the other party. The notice invoking arbitration shall specify all the points of dispute with details of the amount claimed to be referred to arbitration at the time of invocation of arbitration and not thereafter. If the claim is in foreign currency, the claimant shall indicate its value in Indian Rupee for the purpose of constitution of the arbitral tribunal.
- 3) It is agreed and undertaken by the Parties that irrespective of country of origin of the CONTRACTOR, the arbitration proceedings shall be governed by the Arbitration and Conciliation Act, 1996 and under no circumstances, the proceedings shall be construed as International Arbitration.
- 4) The number of arbitrators and the appointing authority will be as under:

Claim Amount (Excluding claim for interest and counter claim, if any)	Number of Arbitrator	Appointing Authority
Upto Rs.25.00 Lakh	Not applicable	Not applicable
Above Rs.25.00 Lakh Upto Rs.25 Crore	Sole Arbitrator	OIL
Above Rs. 25 Crore	3 Arbitrators	One Arbitrator by each party and the 3rd Arbitrator, who shall be the presiding Arbitrator, by the two Arbitrators.

- 5) The parties agree that they shall appoint only those persons as arbitrators who accept the conditions of the arbitration clause. No person shall be appointed as Arbitrator or Presiding Arbitrator who does not accept the conditions of the arbitration clause.
- 6) If any of the Arbitrators so appointed dies, resigns, becomes incapacitated or withdraws for any reason from the proceedings, it shall be lawful for the concerned party/arbitrators to appoint another person in his place in the same manner as aforesaid. Such person shall proceed with the reference from the stage where his predecessor had left if both parties consent for the same; otherwise, he shall proceed de novo.
- 7) Parties agree and undertake that neither shall be entitled for any pre-reference or pendente-lite interest on its claims. Parties agree that any claim for such interest made by any party shall be void.

- 8) The arbitral tribunal shall complete the proceedings, make and publish the award within time stipulated in the Arbitration and Conciliation Act, 1996 (as amended)
- 9) If after commencement of the arbitration proceedings, the parties agree to settle the dispute mutually or refer the dispute to conciliation, the arbitrators shall put the proceedings in abeyance until such period as requested by the parties. Where the proceedings are put in abeyance or terminated on account of mutual settlement of dispute by the parties, the fees payable to the arbitrators shall be determined as under:
- (i) 20% of the fees if the claimant has not submitted statement of claim.
 - (ii) 40% of the fees if the pleadings are complete.
 - (iii) 60% of the fees if the hearing has commenced.
 - (iv) 80% of the fees if the hearing is concluded but the award is yet to be passed.
- 10) Each party shall be responsible to make arrangements for the travel and stay etc. of the arbitrator appointed by it. Claimant shall also be responsible for making arrangements for travel/stay arrangements of the Presiding Arbitrator and the expenses incurred shall be shared equally by the parties. In case of sole arbitrator, both parties shall equally share all expenditures that may be required to be incurred.
- 11) The fees and other administrative/secretarial expenses of the arbitrator(s) shall not exceed the model fee as stipulated in Schedule of the Act and such expenses shall be equally borne by the parties.
- 12) The Place/Seat of Arbitration shall be Guwahati or the place where the contract is executed. The venue of the arbitration shall be decided by the Arbitrator(s) in discussion with the parties. The cost of arbitration sittings shall be equally borne by the parties.
- 13) The Arbitrator(s) shall give reasoned and speaking award and it shall be final and binding on the parties.
- 14) Subject to aforesaid, provisions of the Arbitration and Conciliation Act, 1996 and any statutory modifications or re-enactment thereof shall apply to the arbitration proceedings under this clause.

30.2 Arbitration (Applicable in case of Contract awarded on Public Sector Enterprise):

- a) In the event of any dispute or difference relating to the interpretation and application of the provisions of commercial contract (s) between Central Public Sector Enterprises (CPSEs) and also between CPSEs and Government Departments/Organizations (excluding disputes -concerning Railways, Income Tax, Customs & Excise Departments), such dispute or difference shall be taken up by either party for resolution through AMRCD as mentioned in OPE OM No.4(1)/2013-DPE(GM)/FTS-1835 dated 22-05-2018.
- b) A party wishing to commence arbitration proceeding shall invoke Arbitration Clause and refer the dispute(s) to AMRCD with a copy to the other party. The notice invoking arbitration shall specify all the points of dispute with details of the amount claimed to be referred to arbitration at the time of invocation of arbitration and not thereafter.
- c) Upon such reference, the dispute shall be decided by the Competent Authority appointed under the AMRCD, whose decision shall bind the parties finally and conclusively.

The parties in the dispute will share equally the cost of the arbitration as intimated by the Arbitrator.

30.3 Arbitration (Applicable to Micro, Small and Medium Enterprise)

In the event of any dispute or difference relating to, arising from or connected with the Contract, efforts shall be made to resolve the dispute(s) amicably by mutual consultation and in case such dispute(s) cannot be resolved through mutual consultation, then same shall be resolved through the procedure as prescribed in Section-18 of the Micro, Small and Medium Enterprises Development Act, 2006.

30.4 Resolution of disputes through conciliation by OEC (Not Applicable in cases where value of dispute is less than Rs. 25 Lakhs and more than 2 Crore)

If any dispute, difference, question or disagreement arises between the parties hereto or their respective representatives or assignees, in connection with construction, meaning, operation, effect, interpretation of the contract or breach thereof which parties are unable to settle mutually, Company at its discretion, on its own or on the request of the CONTRACTOR, may refer the dispute to Outside Expert Committee (“OEC”) to be constituted by Corporate Business Committee (CBC), OIL as provided hereunder :

- a) The party desirous of resorting to conciliation shall send a notice of 30 (thirty) days to the other party of its intention of referring the dispute for resolution through OEC. The notice invoking conciliation shall specify all the points of disputes with details of the amount claimed to be referred to OEC and the party concerned shall not raise any new issue thereafter.
- b) OIL shall nominate three outside experts, one each from Financial/commercial, Technical and Legal fields from the Panel of Outside Experts maintained by OIL who shall together be referred to as OEC (Outside Experts Committee).
- c) Parties shall not claim any interest on claims/counterclaims from the date of notice invoking conciliation till execution of settlement agreement, if so arrived at. In case, parties are unable to reach a settlement, no interest shall be claimed by either party for the period from the date of notice invoking conciliation till the date of OEC recommendations in any further proceeding.
- d) The Proceedings of the OEC shall be broadly governed by Part III of the Arbitration and Conciliation Act, 1996 including any modifications thereof. Notwithstanding above, the proceedings shall be summary in nature and Parties agree to rely only upon documentary evidence in support of their claims and not to bring any oral evidence in the OEC proceedings.
- e) OEC shall hear both the parties and recommend possible terms of settlement between the parties. The recommendations of OEC shall be non-binding and the parties may decide to accept or not to accept the same. Parties shall be at liberty to accept the OEC recommendation with any modification they may deem fit.
- f) Where recommendations are acceptable to both the parties, a settlement agreement will be drawn up in terms of the OEC recommendations or with such modifications as may be agreed upon by the parties. The settlement agreement shall be signed by both the parties and authenticated by all the OEC members either in person or through circulation. This settlement agreement shall have the same legal status and effect as that of an arbitration award on agreed terms on the substance of the dispute rendered by an arbitral tribunal under Section 30 of the Arbitration and Conciliation Act, 1996.

- g)** OIL will share all other guidelines regarding reconciliation through OEC with the CONTRACTOR when it resorts to settlement through OEC. Both parties agree to adhere to these guidelines.
- h)** All the expenditure incurred in the OEC proceedings shall be shared by the parties in equal proportion. The parties shall maintain account of expenditure and present to the other for the purpose of sharing on conclusion of the OEC proceedings.
- i)** The OEC proceedings must be completed within a period of 3(three) months from the date of constitution of the OEC with a provision of extension of one months, subject to mutual agreement. The Place of OEC shall be either at New Delhi or Guwahati.
- j)** If the parties are not able to resolve the dispute through OEC or do not opt for conciliation through OEC, the party may invoke arbitration clause as provided in the contract.
- k)** The parties shall be represented by their in-house employees/executives. No party shall bring any advocate or outside consultant/advisor/agent. Ex-officers of OIL who have handled the matter in any capacity directly or indirectly shall not be allowed to attend and present the case before OEC on behalf of Contractor. However, ex- employees of parties may represent their respective organizations.
- l)** Solicitation or any attempt to bring influence of any kind on either OEC Members or OIL is completely prohibited in conciliation proceedings and OIL reserves the absolute right to close the conciliation proceedings at its sole discretion if it apprehends any kind of such attempt made by the Contractor or its representatives.

30.5 Exclusions

Parties agree that following matters shall not be referred to conciliation or arbitration:

- (i)** Any claim, difference or dispute relating to, connected with or arising out of OIL's decision to initiate any proceedings for suspension or debarment or banning, or decision to suspend or to ban or to debar business dealings with the bidder/CONTRACTOR and/or with any other person involved or connected or dealing with bid/contract/bidder/CONTRACTOR.
- (ii)** Any claim, difference or dispute relating to, connected with or arising out of OIL's decision under the provisions of Integrity Pact executed between OIL and the Bidder / Contractor.
- (iii)** Any claim, difference or dispute relating to, connected with or arising out of OIL's decision to comply with any order or directive of any statutory or government authority.
- (iv)** Any claim which is less than Rs. 25 Lakh.

31.0 DISCLAIMERS AND RIGHTS OF BUYER (OIL INDIA LIMITED):

- a)** The issue of the tender document does not imply that the buyer (Oil India Limited) is bound to select bid(s), and it reserves the right without assigning any reason to:
 - i)** reject any or all of the Bids, or
 - ii)** cancel the tender process; or
 - iii)** abandon the procurement of the Goods; or
 - iv)** issue another tender for identical or similar goods

- b) Oil India Limited reserves its right to accept or reject any or all Bids, abandon/ cancel the Tender process, and issue another tender for the same or similar Goods at any time before the award of the contract. It would have no liability to the affected Bidder or Bidders or any obligation to inform the affected Bidder or Bidders of the grounds for such action(s).
- c) Oil India Limited ('Buyer') reserves the right to reject goods which do not conform to the specifications / terms / conditions mentioned in the contract.

32.0 ACKNOWLEDGEMENT OF CONTRACT BY SUCCESSFUL BIDDER AND EXECUTION

- a) After the successful bidder is issued Purchase Order, the supplier should submit the Purchase Order acceptance format duly filled, signed and sealed, within 14 (fourteen) days from the date of issue of the Purchase Order in case of Open Tender / GeM Tender (OTE) and 28 (twenty-eight) days in case of Global Tender Enquiry (GTE).
- b) The successful bidder shall furnish the required performance security (if applicable) within the stipulated timeline mentioned in the contract.
- c) The successful bidder, in case does not furnish the required performance security (if applicable) or does not accept the Purchase Order within the stipulated target dates, such noncompliance will constitute sufficient ground for forfeiture of its bid security / EMD (if applicable) and processing the case for further action against it (the successful bidder) as per the provision of Company's Banning Policy.
- d) The seller must pay all applicable taxes by the contractor or supplier towards execution of contract by Oil India Limited (if awarded).

33.0 FORFEITURE OR ENCASHMENT OF BID SECURITY/EMD (IF APPLICABLE):

The bid security will be forfeited in the following condition:

- (1) The bidder withdraws the bid within its original/extended validity.
- (2) The bidder modifies/revises their bid sumoto.
- (3) Bidder does not accept the order/contract.
- (4) Bidder does not furnish Performance Security Deposit (if applicable) within the stipulated time as per tender/order/contract.
- (5) If it is established that the bidder has submitted fraudulent documents or has indulged into corrupt and fraudulent practice, the bid security shall be forfeited after due process in addition to other action against the bidder as specified in OIL's banning Policy.

34.0 SPECIAL TREATMENT FOR ITEMS COVERED UNDER PRODUCTION LINKED INCENTIVE (PLI) SCHEME:

Purchase Preference is applicable to bidder registered with Department of Promotion of Industry and Internal Trade (DPIIT), Government of India under Production Linked Incentive (PLI) Scheme for the tendered good(s) (if applicable) as per DPIIT's public procurement (Preference to Make In India) Revision Order Date: 19.07.2024 or as amended thereafter as notified by Government of India / Oil India Limited from time to time.

The manufacturers manufacturing an item under PLI scheme shall be treated as deemed Class II local supplier for that item unless they have minimum local content equal to or higher than that notified for Class-I local supplier for that item, provided the manufacturer

has received incentive from the concerned PLI Ministry for the Item. The above shall be applicable for the specific time period only, as notified by concerned PLI Ministry.

Bidder claiming purchase preference under PLI scheme shall declare the same in their letter head duly attaching relevant orders issued by Government of India or respective ministries.

35.0 DENIAL CLAUSE:

In case of default of seller to execute the purchase order within the stipulated delivery period indicated in the purchase order, over and above levy of Liquidated Damages charges (if applicable), any statutory variation (increase/decrease) in the rate of Excise duty/Sales tax/ GST / Customs Duty or any statutory levy and Exchange rate (In case of Global tenders and applicable to foreign bidder/seller) after the closing date of tenders/ revised priced bid, as the case may be, but within the contractual delivery/completion period will be to the account of Oil India Limited (Buyer) subject to documentary evidence. However, any increase in Excise duty/Sales tax/ GST / Customs Duty or any statutory levy and Exchange rate (In case of Global tenders and applicable to foreign bidder/seller) after the expiry of the scheduled date of delivery stipulated in the purchase order (if awarded) shall be to the seller's account. Any decrease in Excise duty/Sales tax/ GST / Customs Duty or any statutory levy and Exchange rate (In case of Global tenders and applicable to foreign bidder/seller) shall be passed on to Oil India Limited (Buyer).

In case of default of seller to execute the purchase order within the stipulated delivery period indicated in the purchase order, Oil India Limited (Buyer) at its discretion may provide extension of delivery date with or without applicable Liquidated Damage charges as provisioned in tender / purchase order (As applicable) subject to the following Denial Clause:

- a) No increases in price on account of any statutory increase in or fresh Imposition of customs duty, GST or on account of any other taxes/duty, including custom duty), leviable in respect of the goods/stores specified in the said purchase order (if awarded) which takes place after the original delivery date indicated in purchase order (if awarded) shall be admissible on such of the said goods/stores, as are delivered after the said date; and
- b) Notwithstanding any stipulation in the contract for increase in price on any other ground including price variation clause (if applicable) or foreign exchange rate variation (if applicable), or any other variation clause, no such increase which takes place after the original delivery date indicated in purchase order (if awarded) shall be admissible on such of the said goods/stores as are delivered after the said date.
- c) Nevertheless, Oil India Limited (Buyer) shall be entitled to the benefit of any decrease in price on account of reduction in or remission of customs duty, GST or on account of any other Tax or duty or on any other ground as stipulated in the price variation clause (if applicable) or foreign exchange rate variation (if applicable) or any other variation clause which takes place after the expiry of the original delivery date indicated in purchase order (if awarded).

36.0 CERTIFICATION OF DOCUMENTS BY INDEPENDENT THIRD-PARTY INSPECTION AGENCIES (TPIA) (IF APPLICABLE):

36.1 Oil India Limited (OIL) has engaged the following 17 (Seventeen) Independent Inspection Agencies for a period of **04 (Four) years up to 06.06.2028** to verify and certify various documents submitted by the bidders required against BEC/BRC of the tender:

Sl. No.	Name of Independent Inspection Agency	Contact E-mail ID
1)	M/s. Dr. Amin Controllers Pvt. Ltd.	1) rkjain@rcaindia.net 2) Pradeep.mathur@rcaindia.net 3) info@rcaindia.net
2)	M/s. TUV India Private Limited	1) noida@tuv-nord.com 2) mumbai@tuv-nord.com 3) salim@tuv-nord.com
3)	M/s. Conformity India International Private Limited	1) mktg@ciindia.in
4)	M/s Ravi Energetic Private Limited	1) baroda@ravienergetic.com 2) tpia@ravienergetic.com
5)	M/s SGS India Private Limited	1) dhaval.vora@sgs.com 2) sgs.india@sgs.com
6)	M/s Assure Quality Management Certification Services Private Limited	1) aqmcs@aqmcs.com
7)	M/s. IRCLASS Systems and Solutions Private Limited	1) industrial_services@irclass.org 2) Bhavesh.satam@irclass.org
8)	M/s. TÜV Rheinland (India) Pvt. Ltd.	1) Shailesh.deotale@ind.tuv.com 2) Kaushal.gohil@ind.tuv.com 3) info@ind.tuv.com 4) ravi.kumar@ind.tuv.com
9)	M/s Gulf Lloyd Industrial Services (I) Pvt. Ltd.	1) contact@gulflloyds.com 2) inspection@gulflloyds.com
10)	M/s Baltic Testing India Pvt. Ltd.	office@balticcontrolindia.com
11)	M/s Sanmarg Engineering Validation & Assessment	Amitra@sanmargeva.com
12)	M/s Meenar Global Consultants LLP	sales@mgellp.in
13)	M/s Rites Limited	1) nrinspn@rites.com 2) info@rites.com 3) sbu.ninspn@rites.com
14)	M/s Bureau Veritas (India) Private Limited	bvindia.corporate@bureauveritas.com
15)	M/s TUV SUD South Asia Private Limited	1) Hemant.chavan@tuvsud.com 2) Jayashree.rane@tuvsud.com
16)	M/s Adornment Engineers India Private Limited	jks@adornmentengineers.com
17)	M/s TCRC Inspections Pvt. Ltd.	1) admin@tereinspections.com 2) ashismallick@teregroup.com 3) tenders@teregroup.com

- 36.2** Bidders are required to have their documents, as mandated under the Bid Evaluation Criteria (BEC) / Bid Rejection Criteria (BRC) of the tender, verified and certified by any one of the empanelled Independent Third-Party Inspection Agencies listed above. The Inspection Certificate, duly issued by the selected agency, must be submitted along with the Technical Bid. **All costs related to verification and certification by the Third-Party Inspection Agencies shall be borne solely by the respective bidders.** Payments in this regard shall be made directly by the bidders to the Inspection Agencies. OIL shall not be held responsible for any payment-related dispute between the bidders and the inspection agencies.
- 36.3** The verified and certified documents must be submitted along with the Technical Bid. Any bid submitted with un-verified supporting documents shall not be considered. However, in case a bidder submits its bid along with all relevant supporting documents as per BEC/BRC without getting all/some of them verified by the designated Independent Inspection agency, such bid can be provisionally considered, provided it is accompanied by an **Undertaking by the Bidder on their official letterhead towards submission of the duly verified and certified copies/ Inspection Certificate within 07 (Seven) days from the actual date of bid opening.** No reminders or clarifications will be issued by the Company in this regard, and failure to submit the verified/ certified documents within the stipulated time shall result in outright rejection of the bid, at the sole risk and responsibility of the bidder.
- 36.4** The methodology of verification/certification of documents followed by the agencies is broadly as under, but not limited to:
- (a) It is the sole responsibility of the bidders intending to participate in the tender to thoroughly understand the requirements of the tender, particularly the documents required under BEC/BRC. The bidders must present all relevant documents to any of the empaneled third-party certifying agencies for verification/certification. Neither OIL nor the Inspection Agencies shall be responsible for the selection or appropriateness of the documents submitted for verification. It is entirely the bidder's responsibility to ensure that the appropriate documents are verified/certified in support of BEC/BRC compliance.
- (b) The concerned Independent Third-Party Inspection Agencies shall depute their qualified/competent inspector to the Bidder's premises to check the original documents and certify the copies which the bidder shall submit along with their bids. OIL will reserve the right to ask the inspection agencies to verify the documents with source, if required at no extra cost to OIL. Verification/Certification of documents by OIL's empaneled third-party inspection agencies shall not automatically make the bidder techno-commercially-acceptable or eligible for award of contract.
- (c) Verification/Certification of documents are normally categorized as under:
- i General Requirement:**
- Check Bidder's PAN Card
 - Check Bidder's GST Certificate
 - Check Bidder's Certificate of Incorporation
 - Power of Attorney

ii Additional Documents : (If applicable against the tender)

- Bidders general structure and organization
- Joint Ventures Agreements – To cross-check with JV Partners
- Consortium Agreements – To cross-check with Consortium Partners
- Holding/Parent/Subsidiary/Sister Subsidiary / Co-Subsidiary Company – To check the Share Holding pattern, Corporate Guarantee etc.

iii Technical Criteria

- To check Experience Proof- Completion Certificates, Reference contact verification, Original Work Order/Contract Copy and any other document(s), if called for vide BEC/BRC of the Tender.
- Health, Safety and Environmental Management Policy

iv Financial Criteria

- Line of credit, if incorporated in the tender.

Notes:

- (i) Bidder's self-declared undertakings, Audited Balance Sheet & Profit-loss statement and/or CA certificate having UDIN are not required to be verified by the TPI agency. If any documents, LOI/LOA/Contracts, etc., submitted towards BEC/BRC experience criteria are issued by Oil India Limited, such documents need not be verified by TPI agency.
- (ii) Undertaking from TPI Agency as per format (**Proforma-U**) enclosed should be submitted along with the Bid.
- (iii) **In case of clarifications sought by OIL against BEC/BRC, supporting documents (historical in nature) to those submitted in the original bid will also have to be verified from the same TPI agency which has originally verified their bid documents. OIL shall categorically mention the documents that are to be submitted with TPI verification in the clarification sought. In case the bidder fails to submit the TPI verified documents, as sought by OIL, as part of their clarification, their offer will be liable for rejection.**



ऑयल इंडिया लिमिटेड

(भारत सरकार का उद्यम)

Oil India Limited

(A Government of India Enterprise)

MATERIALS DEPARTMENT - FIELD HEAD QUARTERS,
P.O., DULIAJAN, DIBRUGARH DISTRICT, ASSAM – 786602

TEL: (+91) 374 2808613

EMAIL: materials@oilindia.in | f_sathiyaraj@oilindia.in

ANNEXURE-IV

Preference to Domestically Manufactured Iron & Steel Products (DMI & SP)

**As per Gazette Notification No.
CG-DL-E-26052025-263378
Date: 26/05/2025 published by
Ministry of Steel, Government
of India (As applicable and
amended from time to time).
Bidder to refer www.steel.gov.in
for more information.**



ऑयल इंडिया लिमिटेड

(भारत सरकार का उद्यम)

Oil India Limited

(A Government of India Enterprise)

MATERIALS DEPARTMENT - FIELD HEAD QUARTERS,
P.O., DULIAJAN, DIBRUGARH DISTRICT, ASSAM – 786602

TEL: (+91) 374 2808613

EMAIL: materials@oilindia.in | f_sathiyaraj@oilindia.in

ANNEXURE-V

GENERAL TERMS AND CONDITIONS FOR SERVICES

NOT APPLICABLE



ऑयल इंडिया लिमिटेड

(भारत सरकार का उद्यम)

Oil India Limited

(A Government of India Enterprise)

MATERIALS DEPARTMENT - FIELD HEAD QUARTERS,
P.O., DULIAJAN, DIBRUGARH DISTRICT, ASSAM – 786602

TEL: (+91) 374 2808613

EMAIL: materials@oilindia.in | f_sathiyaraj@oilindia.in

ANNEXURE-VI

TECHNICAL SPECIFICATIONS & SCOPE OF SUPPLY



Oil India Limited
Materials Department – Field Head Quarters
Duliajan, Assam, India – 786602

ऑयल इंडिया
OIL INDIA

Tel: +91-374-280 8741 | Email: materials@oilindia.in | f_sathiyaraj@oilindia.in
Website: www.oil-india.com

ANNEXURE-VI

SPECIFICATION OF THE TENDERED ITEM

Supply, Installation and Commissioning, Training of Electronic Burner Management System

Tender Quantity	:	6
Unit of Measure	:	Number (NO)
Installation & Commissioning	:	Applicable
Pre-Dispatch Inspection	:	Not Applicable
Training	:	Applicable (i) Type: Onsite (ii) Duration: Two (02) days (iii) Number of Person to be trained: 06 Persons
Delivery Period		
(1) Maximum allowable delivery period in months after receipt of Purchase Order for the case of supply of goods	:	196 Days
(2) Maximum allowable period to complete Installation and Commissioning of supplied goods upon receipt of communication from Buyer Organisation	:	60 Days
(3) Maximum allowable period within which the supplier shall depute their representative after receipt of official intimation from OIL for Installation & Commissioning of the goods	:	20 Days
Delivery Location	:	Oil India Limited, Receiving Section, Materials Department, Duliajan P.O., Dibrugarh District, Assam, India - 786602.

Annexure-VI (A)

TECHNICAL SPECIFICATION

SL. NO.	DESCRIPTION																														
(A)	<p data-bbox="231 353 1487 421">TECHNICAL SPECIFICATIONS FOR BURNER MANAGEMENT SYSTEM (ELECTRONIC) FOR INDIRECT WATER BATH HEATERS:</p> <p data-bbox="231 495 1487 752">The BMS controller (electronic) will be used to primarily control and monitor the complete ignition and firing sequence of the burners installed at the Indirect Water Bath Heaters. It will monitor the presence of pilot flame and will shut off the fuel gas flow if the flame goes out. An auto re-light will try to re-ignite the burner up to three times if there is a flame failure. There will be provisions for dedicated alarm inputs for low fluid level, high bath temperature and low as well as high gas pressure that can be user configurable. The burners shall be designed with atmospheric (natural draft) appliances up to 3.0MMBtu/Hr (refer GAD of the Flame arrested burner as per attachment) and shall be suitable to functioning with the following quality of natural gas available at site:</p> <p data-bbox="231 824 571 853">Composition of Fuel Gas:</p> <table data-bbox="284 882 1203 1615"> <thead> <tr> <th data-bbox="290 889 501 913">CONSTITUTION</th> <th data-bbox="667 889 948 913">Range by % VOLUME</th> </tr> </thead> <tbody> <tr> <td data-bbox="290 943 400 967">Methane</td> <td data-bbox="703 943 863 967">85.7 - 93.52</td> </tr> <tr> <td data-bbox="290 992 384 1016">Ethane</td> <td data-bbox="703 992 852 1016">2.45 - 6.55</td> </tr> <tr> <td data-bbox="290 1041 395 1066">Propane</td> <td data-bbox="703 1041 847 1066">1.28 - 3.12</td> </tr> <tr> <td data-bbox="290 1090 395 1115">Nitrogen</td> <td data-bbox="703 1090 847 1115">0.53 - 1.21</td> </tr> <tr> <td data-bbox="290 1140 485 1164">Carbon-dioxide</td> <td data-bbox="687 1140 836 1164">0.01 - 0.57</td> </tr> <tr> <td data-bbox="290 1189 432 1214">Iso-Butane</td> <td data-bbox="703 1189 847 1214">0.31 - 0.75</td> </tr> <tr> <td data-bbox="290 1238 416 1263">N-Butane</td> <td data-bbox="703 1238 842 1263">0.4 - 1.14</td> </tr> <tr> <td data-bbox="290 1288 443 1312">Iso-Pentane</td> <td data-bbox="703 1288 847 1312">0.19 - 0.47</td> </tr> <tr> <td data-bbox="290 1337 424 1361">N-Pentane</td> <td data-bbox="703 1337 847 1361">0.17 - 0.38</td> </tr> <tr> <td data-bbox="290 1386 384 1411">Hexane</td> <td data-bbox="703 1386 858 1411">0.34 - 1.16</td> </tr> <tr> <td data-bbox="290 1435 384 1460">Gravity</td> <td data-bbox="703 1435 911 1460">0.6204 -0.6919</td> </tr> <tr> <td data-bbox="290 1485 560 1509">Gross Calorific Value</td> <td data-bbox="676 1485 1050 1509">9636.8- 10590.8 Kcal/SCUM</td> </tr> <tr> <td data-bbox="290 1534 528 1559">Net Calorific Value</td> <td data-bbox="676 1534 1038 1559">8704.3- 9595.4 Kcal/SCUM</td> </tr> <tr> <td data-bbox="284 1583 1203 1615">Moisture content: 21.0 - 120.0 LB/MMCFT (336.0 - 1992.0KG/MMSCM)</td> <td></td> </tr> </tbody> </table>	CONSTITUTION	Range by % VOLUME	Methane	85.7 - 93.52	Ethane	2.45 - 6.55	Propane	1.28 - 3.12	Nitrogen	0.53 - 1.21	Carbon-dioxide	0.01 - 0.57	Iso-Butane	0.31 - 0.75	N-Butane	0.4 - 1.14	Iso-Pentane	0.19 - 0.47	N-Pentane	0.17 - 0.38	Hexane	0.34 - 1.16	Gravity	0.6204 -0.6919	Gross Calorific Value	9636.8- 10590.8 Kcal/SCUM	Net Calorific Value	8704.3- 9595.4 Kcal/SCUM	Moisture content: 21.0 - 120.0 LB/MMCFT (336.0 - 1992.0KG/MMSCM)	
CONSTITUTION	Range by % VOLUME																														
Methane	85.7 - 93.52																														
Ethane	2.45 - 6.55																														
Propane	1.28 - 3.12																														
Nitrogen	0.53 - 1.21																														
Carbon-dioxide	0.01 - 0.57																														
Iso-Butane	0.31 - 0.75																														
N-Butane	0.4 - 1.14																														
Iso-Pentane	0.19 - 0.47																														
N-Pentane	0.17 - 0.38																														
Hexane	0.34 - 1.16																														
Gravity	0.6204 -0.6919																														
Gross Calorific Value	9636.8- 10590.8 Kcal/SCUM																														
Net Calorific Value	8704.3- 9595.4 Kcal/SCUM																														
Moisture content: 21.0 - 120.0 LB/MMCFT (336.0 - 1992.0KG/MMSCM)																															

Annexure-VI (A)

TECHNICAL SPECIFICATION

SL. NO.	DESCRIPTION
Technical Specifications for BMS:-	
1	Approvals CSA: Class 1 Division 2 Groups C & D. T4 (BMS Controller) - CSA: C22.2 No. 199 (Combustion Safety Controls and Solid-State Igniters for Gas and Oil Burning Equipment) Or as per OMR 2017.
2	Operating Temperature: 10 to +50°C.
3	Maximum Test Press: 25 PSIG
4	Operating Fuel Gas Pressure (pilot): 10 Psig (Max) - Natural Gas
5	Housing and Parts Materials: Aluminium/SS/Moulded Fiberglass Polyester
6	Power supply: 230VAC available at site. However rectification if required shall be at bidder's scope to cater power supply to BMS, field instruments, SOVs etc.
7	Display type: LCD/Vacuum Fluorescent Display (VFD) with Full Text Message.
8	Operator control: Industrial positive action tactile feedback buttons (Start, Stop, Menu etc.)
9	Pilot Nozzle: Perforated Tip
10	Ignition Module: The Ignition module shall be separately installed in a non-hazardous location, inside the burner housing or other non- hazardous location to meet the requirements as per hazardous area classification. The ignition module shall also have the flame sensing built in technology.
11	Solenoid ratings: 24 VDC
12	Ignition cable: As per requirement.
13	Communications RS 232/485 (Modbus) Remote Communications for monitoring and on/off control only. Multidrop communications via RS485. (Optional)
14	<p>Safety alarms:</p> <ul style="list-style-type: none"> 1 x Low Pressure alarm 1 x High Pressure alarm 1 x Low Liquid Level alarm 1 x High Temperature alarm 1 x Flame failure alarm 1 x Proof of closure input 1 x auxiliary bath High temperature input (temp. switch) 1 x remote stop 1 x remote start <p>Note: The Electronic low liquid level switch shall be installed at existing nozzle of 2" x 150 class. Necessary servo supply (Natural Gas) will be supplied by OIL.</p>
15	Hooter for of above alarms

Annexure-VI (A)

TECHNICAL SPECIFICATION

SL. NO.	DESCRIPTION
16	<p>Approved makes for the related items:</p> <ol style="list-style-type: none"> 1. Pressure regulating valve (main line): Canalta/Emerson/Norriseal-Wellmark/Kimray 2. Y-Strainer: Combustex /Saint/Zoloto 3. Electronic Liquid Level Switch: Emerson / Endress-heuser / Norriseal-WellMark 4. Pressure Gauges: Wika/Forbes Marshall/General/Ashcroft 5. Pressure Switch (High & Low): Switzer/Indfoss/Danfoss/CCS 6. Temperature Control Valve: Emerson/Samson/Norriseal-Wellmark/Forbes-marshall 7. Ball Valves: Parker/Swagelok/L&T/Leader/Comfit 8. Needle valves: Parker/Swagelok/Hylok/Hoke/Comfit 9. Air Filter regulators: Emerson/Fairchild/Norriseal-Wellmark/Shavo 10. Solenoid Valves: ASCO/Rotex/Dungs 11. Thermocouple Assembly including thermowell : Combustex /Wika/GIC/Tempsen 12. I/P Converter: Emerson / Combustex / ABB / Honeywell/ Yokogawa 13. SDV with proof of closure: Combustex /Emerson/Rotex/Kimray 14. Thermocouple cable: Combustex /Tempsen / Omega 15. BMS controller and Ignition module: Combustex/ Profire / ACL/Fire Eye 16. Power Cable: Polycab / Havells / Finolex / KEC / KEI / Lapp India 17. Tubes & Fittings: Sandvik / Parker / Swagelok / Hylok/ Hoke/ Dk-Lok/ Fitok <p>Note: The fuel train shall be of Mild Steel and all accessories like unions, fittings etc. of shall be in the bidder's scope.</p>

(B) Operating Environment for the Burner Management System:

The Burner management system shall be installed at a place within ten (10) meters from the respective Indirect Heaters. Normal operating condition will be 5 to 50 deg. C and 0 to 90 ±10% RH.

(C) Cabling Philosophy:

(i) Signal /multi core cables for the Burner Management System shall be armoured and stranded copper conductor of minimum 1.5 Sq.mm or higher according to power loading calculations.

Annexure-VI (A)

TECHNICAL SPECIFICATION

SL. NO.	DESCRIPTION
(ii)	Power cables shall be three core armoured cables. It will be of stranded copper conductor of minimum 1.5 Sq.mm or higher according to power loading calculations.
(iii)	Control cables for flame-proof external hooter shall be four core armoured cables. It will be of stranded copper conductor of minimum 1.5 Sq.mm or higher according to power loading calculations.
(iv)	There shall not be any cable joints for signal, alarm and control cables.
(v)	All the above ground cables shall be laid in galvanized metallic cable trays. Underground cables shall be laid with proper back filling.
(vii)	Entry of the cables to the operator's room/control room terminating in the control panel should be neat and exposed portion should be routed through cable tray mounted on wall.

(D)	<u>Junction Box:</u>
(i)	Junction boxes shall be weather-proof to IP65. Relevant certificate has to be furnished by the bidder along with their offer.
(ii)	The junction boxes shall be provided with sufficient number of terminals to terminate all the pairs of multi- cable (including spare pairs) and shields of individual pairs as applicable.
(iii)	Junction boxes shall have separate external terminal for accommodating Earthing wires up to 10 sqmm.
(iv)	Unused cable gland entries should be properly sealed with suitable SS blind plugs as per safety standards for Hazardous area applications.

(E)	<u>Cable Glands:</u>
All cable glands shall be double compression type, nickel-plated and weather proof and flameproof suitable for installation in an area classification of IEC Zone I Gas Group IIC. The cable glands shall be provided with PVC hood. Cable glands shall be suitable for cable dimensions with +/- 2mm tolerance. The plugs and adaptors shall also be weather proof and flameproof suitable for installation in an area classification of IEC Zone I Gas Group IIC.	

(F)	<u>Audio-Visual Alarm:</u>
Acoustic and visual alarms shall be automatically activated from the BMS in case of any alarm is triggered. For this purpose, one Industrial grade electric external hooter along with flasher for each BMS shall be supplied and installed in the safe area outside of operator's room/control room within each of the Oil Field installations.	

Annexure-VI (A)

TECHNICAL SPECIFICATION

SL. NO.	DESCRIPTION
(G)	<u>Earthing System:</u>
	Installation & commissioning of the necessary Earthing system for the BMS controller and other instruments shall be under the scope of bidder. The vendor shall supply readymade maintenance free CPRI approved chemical Earthing system with 50 mm dia 3.00 Metres length corrosion free G.I. pipe Electrode and conforming to relevant Indian Standards along with brick earth chamber and earth pit cover. Bidder to specify technical specifications and make in his offer and quote accordingly.

(H)	<u>Installation & Commissioning:</u>
(i)	Installation and commissioning as well as testing of all the Burner Management Systems shall have to be carried out by the successful bidder's competent personnel at various Oil Field Installations within 60 KM radius from Duliajan, Assam (India).
(ii)	During commissioning all required accessories and commissioning spares are to be supplied by the successful bidder/supplier for each OIL Field Installation.
(iii)	Successful bidder/supplier has to erect all the hardware i.e. Field instruments, cable laying, fixing of cable trays, cable termination, fixing of control system along with power supply and hooter etc. and also fabrications, and civil jobs, if any.
(iv)	The successful bidder should design and submit the complete cable schedule and P&ID for OIL's approval prior to execution of the job.
(v)	The Bidder shall be responsible for all types of Civil, Mechanical, Electrical, & Instrumentation works for installation, commissioning, testing and calibration of the entire Burner Management System.
(vi)	Cable laying job for underground cables includes cutting trench, burying cables, laying of cables with good quality brick and sand, covering the trench, marking with cable marker.
(vii)	Cable laying job for over ground/overhead, as required, cables, grouting of supports (to support cable tray) with chips, sand & cement etc. mounting of cable tray with nuts and bolts, laying the cable on the tray, dressing the cable with aluminum strips.
(viii)	The system in each installation will be considered Successfully Commissioned only after successful continuous operation of the system for 72 hours. If any breakdown or malfunctioning of the system in any form is observed during the above observation period, the starting time of observation will be reset to zero. In case the system could not function continuously due to OIL's operational problem, the starting time of observation will not be reset to zero, however, the system shall be made operational and put it under observation by the supplier to complete 72 hours once OIL's operational problem is resolved.

Annexure-VI (A)

TECHNICAL SPECIFICATION

SL. NO.	DESCRIPTION
(I)	NOTES FOR INSTALLATION & COMMISSIONING:
(i)	Bidder shall include unit wise Installation and Commissioning charges in their quoted price.
(ii)	All charges including to and fro fares, boarding/lodging, local transportation at Duliajan, Assam, and other expenses of the Supplier's personnel during their stay at Duliajan shall be under the Supplier's scope.
(iii)	Bidders may make a prior visit to OIL Field Installations at their own cost.
(iv)	No hot work (including all types of welding, cutting, grinding, drilling and heating) shall be permitted within the OIL Field Installations. The successful bidder has to make its own arrangements for handling and transportation of all the material/tools/manpower to and fro the site before and after completion of the work at site, as required.
(v)	The successful bidder shall carry out Work normally during day light hours & irrespective of holidays, Sundays etc. However, in case of emergency, work may have to be done beyond normal working hours with prior permission from Installation Managers.
(vi)	The successful bidder must obtain "Entry Permit" from CISF Commandant/ Head-Security of OIL for all his workers/personnel to enable them to work inside the installations.
(vii)	<p>NUISANCE:</p> <p>The successful bidder or his representative shall not at any point of time cause any nuisance on the site or do anything which shall cause un-necessary disturbance in the installation. OIL reserves the right to reject any one or all the personnel deployed by the successful bidder on the basis of their performance, conduct and discipline. If any replacement is sought by Engineer-in-Charge, the same shall have to be arranged by the successful bidder within 72 Hours or as per instruction of Engineer-in-Charge. In case of any dispute the decision of Engineer-in-Charge shall be final and binding.</p>
(viii)	<p>CARE OF WORKS:</p> <p>From the commencement to completion of work, the successful bidder shall take full responsibility for the care of OIL's property, all equipment and pipelines including all temporary works and in case any damage, loss or injury shall happen to OIL's property/ equipment/ work/ person or to a part thereof due to negligence of the successful bidder, the same shall be rectified/compensated by the successful bidder without any extra claim.</p>
(J)	SAFETY PRACTICES:
(i)	The successful bidder shall abide by all safety and security rules and regulations existing in the OIL's Installations. The successful bidder shall observe the safety measures required to be undertaken for safety of persons, labour, public and properties at work site/ plant premises/ residential premises/ public places etc. The successful bidder shall be required to take work permit from respective shift in charges for each day and each shift for all kind of jobs. There can be instances of not getting permits, withdrawing of permits already issued at any stage of work due some operational safety and security reasons. For any stoppage of work for such reasons no claim whatsoever will be considered.

Annexure-VI (A)

TECHNICAL SPECIFICATION

SL. NO.	DESCRIPTION
(ii)	Stand by firefighting equipment will be deployed at the work site by OIL. However, at least two of the successful bidder's personnel deployed for the work must be capable of handling the firefighting equipment at the time of emergency and the persons will have to be present at the work site throughout the working time. If required the successful bidder's nominated persons will be imparted training on handling such equipment by OIL's Fire Service department.
(iii)	Any compensation arising out of the job carried out by the successful bidder whether related to pollution, Safety or Health will be paid by the successful bidder only.
(iv)	Any compensation arising due to accident of the successful bidder's personnel while carrying out the job, will be payable by the successful bidder.
(v)	The successful bidder shall have to report all incidents including near misses to Installation Manager/ departmental representative of the concerned department of OIL which may occur during execution of the job.
(vi)	In case the successful bidder is found non-compliant of HSE laws as required, the company will have the right for directing the successful bidder to take action to comply with the requirements, and for further non-compliance, the successful bidder will be penalized as per prevailing relevant Acts/ Rules/ Regulations.
(vii)	When there is a significant risk to health, environment or safety of a person or place arising because of a non-compliance of HSE measures, Company will have the right to direct the successful bidder to cease work until the non-compliance is corrected.
(viii)	All safety gears like safety boots, helmets, safety belts, hand gloves, safety goggles, gas masks etc. required for carrying the job in a safe manner shall be arranged by the successful bidder. In case the successful bidder fails to provide the safety gears, the same will be provided by OIL and the cost of such safety items will be deducted from the successful bidder's bills.
(ix)	CLEARANCE OF SITE: As a part of the job, the successful bidder shall completely remove all the temporary/ disposable materials if needed while execution of work or after completion of work at his own cost and dispose off the same as directed by Engineer-in-Charge.
(x)	The successful bidder shall maintain first aid facilities for its employees. All critical industrial injuries shall be reported promptly to EMPLOYER, and a copy of the successful bidder's report covering each personal injury requiring the attention of a physician shall be furnished to the EMPLOYER.
(xi)	The successful bidder shall observe and abide by all fire and safety regulations of the EMPLOYER.
(xii)	The persons executing the work at site shall have valid MVT (Mines Vocational Training) certificate.

Annexure-VI (A)

TECHNICAL SPECIFICATION

SL. NO.	DESCRIPTION
(K)	<u>Site Acceptance Test (SAT):</u>
(i)	OIL shall provisionally takeover the system after satisfactory completion of functional performance test. System acceptance test shall commence only after the satisfactory performance of all the input / outputs of the BMS in each of the OIL Field Installation and verification of records by OIL's engineer at site.
(ii)	Following functional tests shall be part of system acceptance test: <ul style="list-style-type: none"> i. Hardware verification as per final Bill of Material. ii. Visual and mechanical check-up for proper workmanship, identification, ferruling, nameplates etc. iii. System configuration as per approved diagram. Complete set of manual with all operational procedures, ferruling documentation, hooter details and other wirings should be handed over to OIL after commissioning. iv. Demonstration of all system diagnostics. v. Checking of proper functioning of all features, alarm summary etc . of the BMS. vi. Complete Standard Operating Procedure of the BMS shall be handed over to OIL.
(iii)	Only after successful completion of SAT, the complete system shall be put under observation for 72 continuous hours. During this period, any malfunctioning of the system components shall be replaced/repared as required free of cost (under bidder's scope). Once the system failure is detected, the acceptance test shall start all over again from the beginning. On successful completion of 72 hours of continuous operation, the Burner Management system with fuel train shall be accepted by OIL.

(L)	<u>Training:</u>
(i)	Successful Bidder shall impart training to OIL's site personnel for routine operation & preventive maintenance of the Burner Management system. The training shall be imparted at each of OIL Field Installations for minimum 1 (one) day immediately after successful acceptance of the complete system at that particular installation.
(ii)	Cost towards such training / demonstration is inclusive in the installation / commissioning charges.

(M)	<u>Delivery:</u>
(i)	The successful bidder/supplier shall pack and deliver all equipment/items and accessories in separate lots for each of OIL Field Installation. These packed lots shall be clearly marked for site wise deployment for ease of identification and subsequent logistic transportation at the time of installation and commissioning.
(ii)	The equipment/items and accessories shall be packed in robust cartoons so as to avoid damage in transit and for safe storage before/during installation and commissioning.

Annexure-VI (A)

TECHNICAL SPECIFICATION

SL. NO.	DESCRIPTION
(iii)	Time frame for project completion is to be scheduled in two parts. The first part is for supply of items and second part is for Installation & Commissioning. The first part supply of items has to be completed within 28 weeks from issue of Purchase Order (PO) and the second part Installation and Commissioning has to be completed within 60 days from issue of site clearance by OIL. The Bidder needs to provide a tentative project schedule along with bid. Successful bidder required to submit their project execution plan (<i>Details of each tasks pertaining to parts procurement, assembly, testing and function test at works, delivery and shipment schedule</i>) immediately after awarding of PO. This should also include submission of drawings/design calculations for OIL's approval and deputation of engineer/technicians for installation, commissioning, testing and final acceptance test at site including training.
(iv)	The supplied materials including electronic/instruments/cables are required to be stored properly until installation, commissioning, testing and final acceptance of the complete packages. OIL shall provide free space to the bidder for arranging proper storage facilities. For any Damage/pilferage due to poor storage, OIL shall not be responsible for the same.

(N)	<u>GENERAL NOTES:</u>
(a)	It is to be clearly understood that the successful bidder shall be responsible to complete the entire work in all respect and any other work necessary to achieve the object and completion though not specifically covered under the scope of work, shall be carried out by the successful bidder. Bidders are requested to visit the sites prior to submission of their bid so that the exact requirements for items such as Cables, Cable Tray, Junction Box, Cable Gland etc. of the tender could be ascertained and quote accordingly. Tentative requirement is provided in the Annexure – 3 (Bill of Materials).
(b)	The successful bidder shall arrange all the materials labour, tools and tackles etc. required for successful execution of work. OIL shall provide no materials/tools/equipment.
(c)	The successful bidder shall arrange for accommodation/transportation of himself and his supervisor/ labourers at his risk and cost. OIL shall not provide any accommodation / transportation whatsoever to the party or his staff.
(d)	The successful bidder shall employ such workers who are above 18 years of age. All personnel employed by the successful bidder shall have sound health, good character and conduct. They shall be medically fit and fully competent to perform the work.
(e)	OIL shall provide water and electricity required for work. However, necessary arrangement to take electricity and water is under the scope of the successful bidder's.
(f)	Any work not conforming to execution drawings, specifications or codes shall be rejected forthwith and the successful bidder shall carryout the necessary rectification at his own cost.
(g)	If the successful bidder brings labourers from outside the state of Assam, the necessary approval from concerned govt. authorities, labour clearance etc. shall be in his scope.
(h)	The successful bidder shall provide PPE (personal protective equipment) like safety helmets, safety gloves, safety shoes, safety goggles etc. for each person working for the execution of the work, at its own cost. No person will be allowed to work without PPEs.

Annexure-VI (B)

TECHNICAL SPECIFICATION CHECKLIST

Sl. No.	DESCRIPTION	Relevant Location of their Bid to support the remarks / compliance (Reference of Document name / Serial number / Page number of bid for documentary evidence)	BIDDER'S RESPONSE (Complied / Not Complied / Deviation/ Not Applicable)			
(A)	TECHNICAL SPECIFICATIONS FOR BURNER MANAGEMENT SYSTEM (ELECTRONIC) FOR INDIRECT WATER BATH HEATERS:					
	<p>The BMS controller (electronic) will be used to primarily control and monitor the complete ignition and firing sequence of the burners installed at the Indirect Water Bath Heaters. It will monitor the presence of pilot flame and will shut off the fuel gas flow if the flame goes out. An auto re-light will try to re-ignite the burner up to three times if there is a flame failure. There will be provisions for dedicated alarm inputs for low fluid level, high bath temperature and low as well as high gas pressure that can be user configurable. The burners shall be designed with atmospheric (natural draft) appliances up to 3.0MMBtu/Hr (refer GAD of the Flame arrested burner as per attachment) and shall be suitable to functioning with the following quality of natural gas available at site:</p>					
	Composition of Fuel Gas:					
	<table border="1" style="width: 100%; border-collapse: collapse;"> <thead> <tr> <th style="width: 30%; text-align: left;">CONSTITUTION</th> <th style="text-align: left;">Range by % VOLUME</th> </tr> </thead> <tbody> <tr> <td>Methane</td> <td>85.7 - 93.52</td> </tr> </tbody> </table>	CONSTITUTION	Range by % VOLUME	Methane	85.7 - 93.52	
CONSTITUTION	Range by % VOLUME					
Methane	85.7 - 93.52					

(SIGNATURE AND SEAL OF BIDDER)

Annexure-VI (B)

TECHNICAL SPECIFICATION CHECKLIST

Sl. No.	DESCRIPTION	Relevant Location of their Bid to support the remarks / compliance (Reference of Document name / Serial number / Page number of bid for documentary evidence)	BIDDER'S RESPONSE (Complied / Not Complied / Deviation/ Not Applicable)
	Ethane 2.45 - 6.55		
	Propane 1.28 - 3.12		
	Nitrogen 0.53 - 1.21		
	Carbon-dioxide 0.01 - 0.57		
	Iso-Butane 0.31 - 0.75		
	N-Butane 0.4 - 1.14		
	Iso-Pentane 0.19 - 0.47		
	N-Pentane 0.17 - 0.38		
	Hexane 0.34 - 1.16		
	Gravity 0.6204 -0.6919		
	Gross Calorific Value 9636.8- 10590.8 Kcal/SCUM		
	Net Calorific Value 8704.3- 9595.4 Kcal/SCUM		
	Moisture content: 21.0 - 120.0 LB/MMCFT (336.0 - 1992.0KG/MMSCM)		

(SIGNATURE AND SEAL OF BIDDER)

Annexure-VI (B)

TECHNICAL SPECIFICATION CHECKLIST

Sl. No.	DESCRIPTION	Relevant Location of their Bid to support the remarks / compliance (Reference of Document name / Serial number / Page number of bid for documentary evidence)	BIDDER'S RESPONSE (Complied / Not Complied / Deviation/ Not Applicable)
---------	-------------	---	---

Technical Specifications for BMS:-				
1	Approvals CSA: Class 1 Division 2 Groups C & D. T4 (BMS Controller) - CSA: C22.2 No. 199 (Combustion Safety Controls and Solid-State Igniters for Gas and Oil Burning Equipment) Or as per OMR 2017.			
2	Operating Temperature: 10 to +50°C.			
3	Maximum Test Press: 25 PSIG			
4	Operating Fuel Gas Pressure (pilot): 10 Psig (Max) - Natural Gas			
5	Housing and Parts Materials: Aluminium/SS/Moulded Fiberglass Polyester			
6	Power supply: 230VAC available at site. However rectification if required shall be at bidder's scope to cater power supply to BMS, field instruments, SOVs etc.			
7	Display type: LCD/Vacuum Fluorescent Display (VFD) with Full Text Message.			
8	Operator control: Industrial positive action tactile feedback buttons (Start, Stop, Menu etc.)			

(SIGNATURE AND SEAL OF BIDDER)

Annexure-VI (B)

TECHNICAL SPECIFICATION CHECKLIST

Sl. No.	DESCRIPTION	Relevant Location of their Bid to support the remarks / compliance (Reference of Document name / Serial number / Page number of bid for documentary evidence)	BIDDER'S RESPONSE (Complied / Not Complied / Deviation/ Not Applicable)
9	Pilot Nozzle: Perforated Tip		
10	Ignition Module: The Ignition module shall be separately installed in a non-hazardous location, inside the burner housing or other non- hazardous location to meet the requirements as per hazardous area classification. The ignition module shall also have the flame sensing built in technology.		
11	Solenoid ratings: 24 VDC		
12	Ignition cable: As per requirement.		
13	Communications RS 232/485 (Modbus) Remote Communications for monitoring and on/off control only. Multidrop communications via RS485. (Optional)		
14	Safety alarms:		
	1 x Low Pressure alarm		
	1 x High Pressure alarm		
	1 x Low Liquid Level alarm		
	1 x High Temperature alarm		

(SIGNATURE AND SEAL OF BIDDER)

Annexure-VI (B)

TECHNICAL SPECIFICATION CHECKLIST

Sl. No.	DESCRIPTION	Relevant Location of their Bid to support the remarks / compliance (Reference of Document name / Serial number / Page number of bid for documentary evidence)	BIDDER'S RESPONSE (Complied / Not Complied / Deviation/ Not Applicable)
	1 x Flame failure alarm 1 x Proof of closure input 1 x auxiliary bath High temperature input (temp. switch) 1 x remote stop 1 x remote start Note: The Electronic low liquid level switch shall be installed at existing nozzle of 2" x 150 class. Necessary servo supply (Natural Gas) will be supplied by OIL.		
15	Hooter for of above alarms		
16	Approved makes for the related items: 1. Pressure regulating valve (main line): Canalta/Emerson/Norriseal-Wellmark/Kimray 2. Y-Strainer: Combustex /Saint/Zoloto 3. Electronic Liquid Level Switch: Emerson / Endress-heuser / Norriseal-WellMark		

(SIGNATURE AND SEAL OF BIDDER)

Annexure-VI (B)

TECHNICAL SPECIFICATION CHECKLIST

Sl. No.	DESCRIPTION	Relevant Location of their Bid to support the remarks / compliance (Reference of Document name / Serial number / Page number of bid for documentary evidence)	BIDDER'S RESPONSE (Complied / Not Complied / Deviation/ Not Applicable)
	4. Pressure Gauges: Wika/Forbes Marshall/General/Ashcroft		
	5. Pressure Switch (High & Low): Switzer/Indfoss/Danfoss/CCS		
	6. Temperature Control Valve: Emerson/Samson/Norriseal-Wellmark/Forbes-marshall		
	7. Ball Valves: Parker/Swagelok/L&T/Leader/Comfit		
	8. Needle valves: Parker/Swagelok/Hylok/Hoke/Comfit		
	9. Air Filter regulators: Emerson/Fairchild/Norriseal-Wellmark/Shavo		
	10. Solenoid Valves: ASCO/Rotex/Dungs		
	11. Thermocouple Assembly including thermowell : Combustex /Wika/GIC/Tempsen		
	12. I/P Converter: Emerson / Combustex / ABB / Honeywell/ Yokogawa		
	13. SDV with proof of closure: Combustex /Emerson/Rotex/Kimray		

(SIGNATURE AND SEAL OF BIDDER)

Annexure-VI (B)

TECHNICAL SPECIFICATION CHECKLIST

Sl. No.	DESCRIPTION	Relevant Location of their Bid to support the remarks / compliance (Reference of Document name / Serial number / Page number of bid for documentary evidence)	BIDDER'S RESPONSE (Complied / Not Complied / Deviation/ Not Applicable)
	14. Thermocouple cable: Combustex /Tempsen / Omega		
	15. BMS controller and Ignition module: Combustex/ Profire / ACL/Fire Eye		
	16. Power Cable: Polycab / Havells / Finolex / KEC /KEI / Lapp India		
	17. Tubes & Fittings: Sandvik / Parker / Swagelok / Hyllok/ Hoke/ Dk-Lok/ Fitok		
	Note: The fuel train shall be of Mild Steel and all accessories like unions, fittings etc. of shall be in the bidder's scope.		

(B)	Operating Environment for the Burner Management System:		
	The Burner management system shall be installed at a place within ten (10) meters from the respective Indirect Heaters. Normal operating condition will be 5 to 50 deg. C and 0 to 90 ±10% RH.		

(SIGNATURE AND SEAL OF BIDDER)

Annexure-VI (B)

TECHNICAL SPECIFICATION CHECKLIST

Sl. No.	DESCRIPTION	Relevant Location of their Bid to support the remarks / compliance (Reference of Document name / Serial number / Page number of bid for documentary evidence)	BIDDER'S RESPONSE (Complied / Not Complied / Deviation/ Not Applicable)
(C)	Cabling Philosophy:		
(i)	Signal /multi core cables for the Burner Management System shall be armoured and stranded copper conductor of minimum 1.5 Sq.mm or higher according to power loading calculations.		
(ii)	Power cables shall be three core armoured cables. It will be of stranded copper conductor of minimum 1.5 Sq.mm or higher according to power loading calculations.		
(iii)	Control cables for flame-proof external hooter shall be four core armoured cables. It will be of stranded copper conductor of minimum 1.5 Sq.mm or higher according to power loading calculations.		
(iv)	There shall not be any cable joints for signal, alarm and control cables.		
(v)	All the above ground cables shall be laid in galvanized metallic cable trays. Underground cables shall be laid with proper back filling.		

(SIGNATURE AND SEAL OF BIDDER)

Annexure-VI (B)

TECHNICAL SPECIFICATION CHECKLIST

Sl. No.	DESCRIPTION	Relevant Location of their Bid to support the remarks / compliance (Reference of Document name / Serial number / Page number of bid for documentary evidence)	BIDDER'S RESPONSE (Complied / Not Complied / Deviation/ Not Applicable)
(vii)	Entry of the cables to the operator's room/control room terminating in the control panel should be neat and exposed portion should be routed through cable tray mounted on wall.		

(D)	Junction Box:		
(i)	Junction boxes shall be weather-proof to IP65. Relevant certificate has to be furnished by the bidder along with their offer.		
(ii)	The junction boxes shall be provided with sufficient number of terminals to terminate all the pairs of multi- cable (including spare pairs) and shields of individual pairs as applicable.		
(iii)	Junction boxes shall have separate external terminal for accommodating Earthing wires up to 10 sqmm.		
(iv)	Unused cable gland entries should be properly sealed with suitable SS blind plugs as per safety standards for Hazardous area applications.		

(SIGNATURE AND SEAL OF BIDDER)

Annexure-VI (B)

TECHNICAL SPECIFICATION CHECKLIST

Sl. No.	DESCRIPTION	Relevant Location of their Bid to support the remarks / compliance (Reference of Document name / Serial number / Page number of bid for documentary evidence)	BIDDER'S RESPONSE (Complied / Not Complied / Deviation/ Not Applicable)
(E)	<u>Cable Glands:</u>		
	All cable glands shall be double compression type, nickel-plated and weather proof and flameproof suitable for installation in an area classification of IEC Zone I Gas Group IIC. The cable glands shall be provided with PVC hood. Cable glands shall be suitable for cable dimensions with +/- 2mm tolerance. The plugs and adaptors shall also be weather proof and flameproof suitable for installation in an area classification of IEC Zone I Gas Group IIC.		
(F)	<u>Audio-Visual Alarm:</u>		
	Acoustic and visual alarms shall be automatically activated from the BMS in case of any alarm is triggered. For this purpose, one Industrial grade electric external hooter along with flasher for each BMS shall be supplied and installed in the safe area outside of operator's room/control room within each of the Oil Field installations.		

(SIGNATURE AND SEAL OF BIDDER)

Annexure-VI (B)

TECHNICAL SPECIFICATION CHECKLIST

Sl. No.	DESCRIPTION	Relevant Location of their Bid to support the remarks / compliance (Reference of Document name / Serial number / Page number of bid for documentary evidence)	BIDDER'S RESPONSE (Complied / Not Complied / Deviation/ Not Applicable)
(G)	<u>Earthing System:</u>		
	Installation & commissioning of the necessary Earthing system for the BMS controller and other instruments shall be under the scope of bidder. The vendor shall supply readymade maintenance free CPRI approved chemical Earthing system with 50 mm dia 3.00 Metres length corrosion free G.I. pipe Electrode and conforming to relevant Indian Standards along with brick earth chamber and earth pit cover. Bidder to specify technical specifications and make in his offer and quote accordingly.		
(H)	<u>Installation & Commissioning:</u>		
(i)	Installation and commissioning as well as testing of all the Burner Management Systems shall have to be carried out by the successful bidder's competent personnel at various Oil Field Installations within 60 KM radius from Duliajan, Assam (India).		
(ii)	During commissioning all required accessories and commissioning spares are to be supplied by the successful bidder/supplier for each OIL Field Installation.		

(SIGNATURE AND SEAL OF BIDDER)

Annexure-VI (B)

TECHNICAL SPECIFICATION CHECKLIST

Sl. No.	DESCRIPTION	Relevant Location of their Bid to support the remarks / compliance (Reference of Document name / Serial number / Page number of bid for documentary evidence)	BIDDER'S RESPONSE (Complied / Not Complied / Deviation/ Not Applicable)
(iii)	Successful bidder/supplier has to erect all the hardware i.e. Field instruments, cable laying, fixing of cable trays, cable termination, fixing of control system along with power supply and hooter etc. and also fabrications, and civil jobs, if any.		
(iv)	The successful bidder should design and submit the complete cable schedule and P&ID for OIL's approval prior to execution of the job.		
(v)	The Bidder shall be responsible for all types of Civil, Mechanical, Electrical, & Instrumentation works for installation, commissioning, testing and calibration of the entire Burner Management System.		
(vi)	Cable laying job for underground cables includes cutting trench, burying cables, laying of cables with good quality brick and sand, covering the trench, marking with cable marker.		
(vii)	Cable laying job for over ground/overhead, as required, cables, grouting of supports (to support cable tray) with chips, sand & cement etc. mounting of cable tray with nuts and bolts, laying the cable on the tray, dressing the cable with aluminum strips.		

(SIGNATURE AND SEAL OF BIDDER)

Annexure-VI (B)

TECHNICAL SPECIFICATION CHECKLIST

Sl. No.	DESCRIPTION	Relevant Location of their Bid to support the remarks / compliance (Reference of Document name / Serial number / Page number of bid for documentary evidence)	BIDDER'S RESPONSE (Complied / Not Complied / Deviation/ Not Applicable)
(viii)	The system in each installation will be considered Successfully Commissioned only after successful continuous operation of the system for 72 hours. If any breakdown or malfunctioning of the system in any form is observed during the above observation period, the starting time of observation will be reset to zero. In case the system could not function continuously due to OIL's operational problem, the starting time of observation will not be reset to zero, however, the system shall be made operational and put it under observation by the supplier to complete 72 hours once OIL's operational problem is resolved.		

(I)	NOTES FOR INSTALLATION & COMMISSIONING:		
(i)	Bidder shall include unit wise Installation and Commissioning charges in their quoted price.		
(ii)	All charges including to and fro fares, boarding/lodging, local transportation at Duliajan, Assam, and other expenses of the Supplier's personnel during their stay at Duliajan shall be under the Supplier's scope.		
(iii)	Bidders may make a prior visit to OIL Field Installations at their own cost.		

(SIGNATURE AND SEAL OF BIDDER)

Annexure-VI (B)

TECHNICAL SPECIFICATION CHECKLIST

Sl. No.	DESCRIPTION	Relevant Location of their Bid to support the remarks / compliance (Reference of Document name / Serial number / Page number of bid for documentary evidence)	BIDDER'S RESPONSE (Complied / Not Complied / Deviation/ Not Applicable)
(iv)	No hot work (including all types of welding, cutting, grinding, drilling and heating) shall be permitted within the OIL Field Installations. The successful bidder has to make its own arrangements for handling and transportation of all the material/tools/manpower to and fro the site before and after completion of the work at site, as required.		
(v)	The successful bidder shall carry out Work normally during day light hours & irrespective of holidays, Sundays etc. However, in case of emergency, work may have to be done beyond normal working hours with prior permission from Installation Managers.		
(vi)	The successful bidder must obtain "Entry Permit" from CISF Commandant/ Head-Security of OIL for all his workers/personnel to enable them to work inside the installations.		

(SIGNATURE AND SEAL OF BIDDER)

Annexure-VI (B)

TECHNICAL SPECIFICATION CHECKLIST

Sl. No.	DESCRIPTION	Relevant Location of their Bid to support the remarks / compliance (Reference of Document name / Serial number / Page number of bid for documentary evidence)	BIDDER'S RESPONSE (Complied / Not Complied / Deviation/ Not Applicable)
(vii)	<p><u>NUISANCE:</u> The successful bidder or his representative shall not at any point of time cause any nuisance on the site or do anything which shall cause un-necessary disturbance in the installation. OIL reserves the right to reject any one or all the personnel deployed by the successful bidder on the basis of their performance, conduct and discipline. If any replacement is sought by Engineer-in-Charge, the same shall have to be arranged by the successful bidder within 72 Hours or as per instruction of Engineer-in-Charge. In case of any dispute the decision of Engineer-in-Charge shall be final and binding.</p>		
(viii)	<p><u>CARE OF WORKS:</u> From the commencement to completion of work, the successful bidder shall take full responsibility for the care of OIL's property, all equipment and pipelines including all temporary works and in case any damage, loss or injury shall happen to OIL's property/ equipment/ work/ person or to a part thereof due to negligence of the successful bidder, the same shall be rectified/compensated by the successful bidder without any extra claim.</p>		

(SIGNATURE AND SEAL OF BIDDER)

Annexure-VI (B)

TECHNICAL SPECIFICATION CHECKLIST

Sl. No.	DESCRIPTION	Relevant Location of their Bid to support the remarks / compliance (Reference of Document name / Serial number / Page number of bid for documentary evidence)	BIDDER'S RESPONSE (Complied / Not Complied / Deviation/ Not Applicable)
(J)	<u>SAFETY PRACTICES:</u>		
(i)	The successful bidder shall abide by all safety and security rules and regulations existing in the OIL's Installations. The successful bidder shall observe the safety measures required to be undertaken for safety of persons, labour, public and properties at work site/ plant premises/ residential premises/ public places etc. The successful bidder shall be required to take work permit from respective shift in charges for each day and each shift for all kind of jobs. There can be instances of not getting permits, withdrawing of permits already issued at any stage of work due some operational safety and security reasons. For any stoppage of work for such reasons no claim whatsoever will be considered.		
(ii)	Stand by firefighting equipment will be deployed at the work site by OIL. However, at least two of the successful bidder's personnel deployed for the work must be capable of handling the firefighting equipment at the time of emergency and the persons will have to be present at the work site throughout the working time. If required the successful bidder's nominated persons will be imparted training on handling such equipment by OIL's Fire Service department.		

(SIGNATURE AND SEAL OF BIDDER)

Annexure-VI (B)

TECHNICAL SPECIFICATION CHECKLIST

Sl. No.	DESCRIPTION	Relevant Location of their Bid to support the remarks / compliance (Reference of Document name / Serial number / Page number of bid for documentary evidence)	BIDDER'S RESPONSE (Complied / Not Complied / Deviation/ Not Applicable)
(iii)	Any compensation arising out of the job carried out by the successful bidder whether related to pollution, Safety or Health will be paid by the successful bidder only.		
(iv)	Any compensation arising due to accident of the successful bidder's personnel while carrying out the job, will be payable by the successful bidder.		
(v)	The successful bidder shall have to report all incidents including near misses to Installation Manager/ departmental representative of the concerned department of OIL which may occur during execution of the job.		
(vi)	In case the successful bidder is found non-compliant of HSE laws as required, the company will have the right for directing the successful bidder to take action to comply with the requirements, and for further non-compliance, the successful bidder will be penalized as per prevailing relevant Acts/ Rules/ Regulations.		
(vii)	When there is a significant risk to health, environment or safety of a person or place arising because of a non-compliance of HSE measures, Company will have the right to direct the successful bidder to cease work until the non-compliance is corrected.		

(SIGNATURE AND SEAL OF BIDDER)

Annexure-VI (B)

TECHNICAL SPECIFICATION CHECKLIST

Sl. No.	DESCRIPTION	Relevant Location of their Bid to support the remarks / compliance (Reference of Document name / Serial number / Page number of bid for documentary evidence)	BIDDER'S RESPONSE (Complied / Not Complied / Deviation/ Not Applicable)
(viii)	All safety gears like safety boots, helmets, safety belts, hand gloves, safety goggles, gas masks etc. required for carrying the job in a safe manner shall be arranged by the successful bidder. In case the successful bidder fails to provide the safety gears, the same will be provided by OIL and the cost of such safety items will be deducted from the successful bidder's bills.		
(ix)	CLEARANCE OF SITE: As a part of the job, the successful bidder shall completely remove all the temporary/ disposable materials if needed while execution of work or after completion of work at his own cost and dispose off the same as directed by Engineer-in-Charge.		
(x)	The successful bidder shall maintain first aid facilities for its employees. All critical industrial injuries shall be reported promptly to EMPLOYER, and a copy of the successful bidder's report covering each personal injury requiring the attention of a physician shall be furnished to the EMPLOYER.		
(xi)	The successful bidder shall observe and abide by all fire and safety regulations of the EMPLOYER.		

(SIGNATURE AND SEAL OF BIDDER)

Annexure-VI (B)

TECHNICAL SPECIFICATION CHECKLIST

Sl. No.	DESCRIPTION	Relevant Location of their Bid to support the remarks / compliance (Reference of Document name / Serial number / Page number of bid for documentary evidence)	BIDDER'S RESPONSE (Complied / Not Complied / Deviation/ Not Applicable)
(xii)	The persons executing the work at site shall have valid MVT (Mines Vocational Training) certificate.		

(K)	Site Acceptance Test (SAT):		
(i)	OIL shall provisionally takeover the system after satisfactory completion of functional performance test. System acceptance test shall commence only after the satisfactory performance of all the input / outputs of the BMS in each of the OIL Field Installation and verification of records by OIL's engineer at site.		
(ii)	Following functional tests shall be part of system acceptance test:		
	i. Hardware verification as per final Bill of Material.		
	ii. Visual and mechanical check-up for proper workmanship, identification, ferruling, nameplates etc.		

(SIGNATURE AND SEAL OF BIDDER)

Annexure-VI (B)

TECHNICAL SPECIFICATION CHECKLIST

Sl. No.	DESCRIPTION	Relevant Location of their Bid to support the remarks / compliance (Reference of Document name / Serial number / Page number of bid for documentary evidence)	BIDDER'S RESPONSE (Complied / Not Complied / Deviation/ Not Applicable)
	iii. System configuration as per approved diagram. Complete set of manual with all operational procedures, ferruling documentation, hooter details and other wirings should be handed over to OIL after commissioning.		
	iv. Demonstration of all system diagnostics.		
	v. Checking of proper functioning of all features, alarm summary etc . of the BMS.		
	vi. Complete Standard Operating Procedure of the BMS shall be handed over to OIL.		
(iii)	Only after successful completion of SAT, the complete system shall be put under observation for 72 continuous hours. During this period, any malfunctioning of the system components shall be replaced/repared as required free of cost (under bidder's scope). Once the system failure is detected, the acceptance test shall start all over again from the beginning. On successful completion of 72 hours of continuous operation, the Burner Management system with fuel train shall be accepted by OIL.		

(SIGNATURE AND SEAL OF BIDDER)

Annexure-VI (B)

TECHNICAL SPECIFICATION CHECKLIST

Sl. No.	DESCRIPTION	Relevant Location of their Bid to support the remarks / compliance (Reference of Document name / Serial number / Page number of bid for documentary evidence)	BIDDER'S RESPONSE (Complied / Not Complied / Deviation/ Not Applicable)
(L)	Training:		
(i)	Successful Bidder shall impart training to OIL's site personnel for routine operation & preventive maintenance of the Burner Management system. The training shall be imparted at each of OIL Field Installations for minimum 1 (one) day immediately after successful acceptance of the complete system at that particular installation.		
(ii)	Cost towards such training / demonstration is inclusive in the installation / commissioning charges.		
(M)	Delivery:		
(i)	The successful bidder/supplier shall pack and deliver all equipment/items and accessories in separate lots for each of OIL Field Installation. These packed lots shall be clearly marked for site wise deployment for ease of identification and subsequent logistic transportation at the time of installation and commissioning.		

(SIGNATURE AND SEAL OF BIDDER)

Annexure-VI (B)

TECHNICAL SPECIFICATION CHECKLIST

Sl. No.	DESCRIPTION	Relevant Location of their Bid to support the remarks / compliance (Reference of Document name / Serial number / Page number of bid for documentary evidence)	BIDDER'S RESPONSE (Complied / Not Complied / Deviation/ Not Applicable)
(ii)	The equipment/items and accessories shall be packed in robust cartoons so as to avoid damage in transit and for safe storage before/during installation and commissioning.		
(iii)	Time frame for project completion is to be scheduled in two parts. The first part is for supply of items and second part is for Installation & Commissioning. The first part supply of items has to be completed within 28 weeks from issue of Purchase Order (PO) and the second part Installation and Commissioning has to be completed within 60 days from issue of site clearance by OIL. The Bidder needs to provide a tentative project schedule along with bid. Successful bidder required to submit their project execution plan (<i>Details of each tasks pertaining to parts procurement, assembly, testing and function test at works, delivery and shipment schedule</i>) immediately after awarding of PO. This should also include submission of drawings/design calculations for OIL's approval and deputation of engineer/technicians for installation, commissioning, testing and final acceptance test at site including training.		
(iv)	The supplied materials including electronic/instruments/cables are required to be stored properly until installation, commissioning, testing and final acceptance of the complete packages. OIL shall provide free space to the bidder for arranging proper storage facilities. For any Damage/pilferage due to poor storage, OIL shall not be responsible for the same.		

(SIGNATURE AND SEAL OF BIDDER)

Annexure-VI (B)

TECHNICAL SPECIFICATION CHECKLIST

Sl. No.	DESCRIPTION	Relevant Location of their Bid to support the remarks / compliance (Reference of Document name / Serial number / Page number of bid for documentary evidence)	BIDDER'S RESPONSE (Complied / Not Complied / Deviation/ Not Applicable)
---------	-------------	---	---

(N)	GENERAL NOTES:		
(a)	It is to be clearly understood that the successful bidder shall be responsible to complete the entire work in all respect and any other work necessary to achieve the object and completion though not specifically covered under the scope of work, shall be carried out by the successful bidder. Bidders are requested to visit the sites prior to submission of their bid so that the exact requirements for items such as Cables, Cable Tray, Junction Box, Cable Gland etc. of the tender could be ascertained and quote accordingly. Tentative requirement is provided in the Annexure - 3 (Bill of Materials).		
(b)	The successful bidder shall arrange all the materials labour, tools and tackles etc. required for successful execution of work. OIL shall provide no materials/tools/equipment.		
(c)	The successful bidder shall arrange for accommodation/transportation of himself and his supervisor/ labourers at his risk and cost. OIL shall not provide any accommodation / transportation whatsoever to the party or his staff.		

(SIGNATURE AND SEAL OF BIDDER)

Annexure-VI (B)

TECHNICAL SPECIFICATION CHECKLIST

Sl. No.	DESCRIPTION	Relevant Location of their Bid to support the remarks / compliance (Reference of Document name / Serial number / Page number of bid for documentary evidence)	BIDDER'S RESPONSE (Complied / Not Complied / Deviation/ Not Applicable)
(d)	The successful bidder shall employ such workers who are above 18 years of age. All personnel employed by the successful bidder shall have sound health, good character and conduct. They shall be medically fit and fully competent to perform the work.		
(e)	OIL shall provide water and electricity required for work. However, necessary arrangement to take electricity and water is under the scope of the successful bidder's.		
(f)	Any work not conforming to execution drawings, specifications or codes shall be rejected forthwith and the successful bidder shall carryout the necessary rectification at his own cost.		
(g)	If the successful bidder brings labourers from outside the state of Assam, the necessary approval from concerned govt. authorities, labour clearance etc. shall be in his scope.		
(h)	The successful bidder shall provide PPE (personal protective equipment) like safety helmets, safety gloves, safety shoes, safety goggles etc. for each person working for the execution of the work, at its own cost. No person will be allowed to work without PPEs.		

(SIGNATURE AND SEAL OF BIDDER)

Annexure-VI (B)

TECHNICAL SPECIFICATION CHECKLIST

Sl. No.	DESCRIPTION	Relevant Location of their Bid to support the remarks / compliance (Reference of Document name / Serial number / Page number of bid for documentary evidence)	BIDDER'S RESPONSE (Complied / Not Complied / Deviation/ Not Applicable)
Special Notes:			
a)	The scope of supply and installation shall include Burner Management System (Electronic) with Fuel Train including all accessories for successful commissioning.		
b)	The bidder must provide all relevant technical catalogues of the offered make and model of the proposed instruments, BMS controller, SOVs, Hooters and other accessories along with their bid for technical evaluation.		
c)	I) All electronic/electrical instruments and equipment to be used in hazardous area shall fulfil the following:		
	a. Item shall be of a type and specification conforming to the relevant standards as specified in the Regulation 107(2) of Oil Mines Regulation-2017 and complying the provisions therein.		

(SIGNATURE AND SEAL OF BIDDER)

Annexure-VI (B)

TECHNICAL SPECIFICATION CHECKLIST

Sl. No.	DESCRIPTION	Relevant Location of their Bid to support the remarks / compliance (Reference of Document name / Serial number / Page number of bid for documentary evidence)	BIDDER'S RESPONSE (Complied / Not Complied / Deviation/ Not Applicable)
	<p>b. Bidder shall provide documents specifying the type, details of specification, reference of the particular standard, test criteria as per the standards and status of testing, place of testing, copies of test reports from Indian Government Laboratory or NABL accredited laboratory or IECEX accredited laboratory or ATEX notified body which is not a part of manufacture's facilities along with their offer against this tender.</p>		
	<p>c. In this regard, Bidder may refer OMR-2017, Notification dated 18th October 2017, published in the Gazette of India, under Ministry of Labour and Employment, Directorate General of Mines Safety, published on 2nd November 2017. Copy of the gazette notification shall be attached for reference.</p>		
d)	The bidder must categorically confirm in writing that their supplied items will be as per the makes mentioned in point no. A. (16) .		
e)	The P&ID diagram of the proposed system shall be submitted to OIL for evaluation purpose. However the same need to be approved from OIL before execution.		

(SIGNATURE AND SEAL OF BIDDER)

Annexure-VI (B)

TECHNICAL SPECIFICATION CHECKLIST

Sl. No.	DESCRIPTION	Relevant Location of their Bid to support the remarks / compliance (Reference of Document name / Serial number / Page number of bid for documentary evidence)	BIDDER'S RESPONSE (Complied / Not Complied / Deviation/ Not Applicable)
f)	230 VAC supply shall be provided by OIL. Necessary rectification to 24 VDC shall be in bidder's scope.		
g)	The successful bidder must supply one (01) hard copy of Operation & Maintenance manual of all the instruments and BMS controller (for each installation).		
h)	OIL reserves the right to inspect, test and if necessary reject any part/parts after delivery at site (including incomplete manuals, catalogues, etc.). In case of any fault on the part of the supplier he has to replace/repair at his own cost.		
i)	Supply of all necessary accessories & fittings like-pipe, cable tray, Junction Box, Cable gland, cable tie, nut bolt, screw, clamp, etc. required to complete the installation and commission of the BMS is under the scope of the bidder and should be included in their quoted price.		
j)	The supplier must submit an undertaking along with the bid that the spares and consumables for the Burner management system shall be available for next six (06) years from the date of successful commissioning.		

(SIGNATURE AND SEAL OF BIDDER)

Annexure-VI (B)

TECHNICAL SPECIFICATION CHECKLIST

Sl. No.	DESCRIPTION	Relevant Location of their Bid to support the remarks / compliance (Reference of Document name / Serial number / Page number of bid for documentary evidence)	BIDDER'S RESPONSE (Complied / Not Complied / Deviation/ Not Applicable)
k)	Since these BMS will be installed with the indirect heaters which are currently in operation, hence minimum downtime will be allowed for the job.		

(SIGNATURE AND SEAL OF BIDDER)

Annexure-VI (C)

Bill Of Material (BOM) - Electronic Burner Management System for each package**Note: This is a reference BoM only.**

SL. NO.	DESCRIPTION	QTY	UNIT	REMARKS
1	1" unions	6	Nos.	
2	1" ball valve	2	Nos.	Main Isolation valve for fuel train (1.Inlet and 2.Before entering the burner)
3	1/2 " Drain Valve	2	Nos.	
4	Y-Strainer	1	No	
5	1/2 " needle valve with mounting nipple and pressure gauge adaptor	1	No	0- 20 KG/ CM2 pressure gauge mounting
6	Pressure Gauge(0- 25 Kg/cm2)	1	No	Fuel Pressure in the main line before PRV (Main Burner)
7	1/4" or 1/2" needle valve with mounting nipple	2	Nos.	Line for servo in the main line before PRV (Main Burner)
8	1 " PRV (250 PSI to 22 PSI)	1	No	Main fuel line PRV
9	1/2 " needle valve with mounting nipple and pressure gauge adaptor	2	Nos.	0- 5 KG/ CM2 pressure gauge mounting
10	Pressure Gauge(0- 5 Kg/cm2)	2	Nos.	Fuel Pressure in the main line after PRV (Main Burner) and after Safety shut off valve
11	1/2 " Needle valve with mounting nipple and pressure switch adaptor	2	Nos.	Fuel Pressure HH and LL tripping switch mounting
12	Pressure Switch (0-2.5 kg/cm2)	2	Nos.	Fuel Pressure HH and LL tripping

(SIGNATURE AND COMPANY SEAL OF BIDDER)

Annexure-VI (C)

Bill Of Material (BOM) - Electronic Burner Management System for each package**Note: This is a reference BoM only.**

SL. NO.	DESCRIPTION	QTY	UNIT	REMARKS
13	1" Safety shut off valve with proof of closure (SSOV with POC)	1	No	Main burner fuel Shut off Normally close
14	1/4" SOV	1	No	For SSOV
15	Temperature Element	1	No	Thermocouple for bath temperature
16	Temperature Gauges	2	Nos.	0-100 Deg C
16	1" Thermo well	1	No	Mounting thermocouple for bath temperature
17	Temperature Control Valve with positioner	1	No	Normally Close
18	I/P converter	1	No	4-20 mA to 3- 15 psig or 0.2 kg/cm ² to 1 kg/cm ²
19	AFR	2	Nos.	For Valve positioner and I/P converter
20	Isolation valve 1/4 " (Needle or Ball)	2	Nos.	For Valve positioner and I/P converter
21	1/4" or 1/2" ball valve	1	No	For Pilot line
22	1/4" or 1/2" PRV (50 PSI to 5 PSI)	1	No	For Pilot Burner
23	1/4" or 1/2 " needle valve with mounting nipple and pressure gauge adaptor	1	No	0- 2 KG/ CM ² pressure gauge mounting

(SIGNATURE AND COMPANY SEAL OF BIDDER)

Annexure-VI (C)

Bill Of Material (BOM) - Electronic Burner Management System for each package**Note: This is a reference BoM only.**

SL. NO.	DESCRIPTION	QTY	UNIT	REMARKS
24	1/2" SOV	1	No	For Pilot burner fuel line (Normally close)
25	Pressure Gauge(0- 2 Kg/cm ²)	1	No	Pilot Burner pressure
26	Liquid level switch (Electronic)	1	No	
26	Needle Valve	1	No	Valve for Pilot line Isolation
27	Burner Management system with ignition system	1	No	
28	FRP canopy for BMS	1	No	
29	Audio alarm system with accessories	1	Set	For audio indication in case of trip
30	Pilot Burner Assembly with accessories	1	No	
31	1/4" SS tubing	24	Mtrs	For Servo line to TCV, I/P, SOV etc
32	1/4" (M) Straight Connector	30	Nos.	For Servo line to TCV, I/P, SOV etc
33	1/4 " Straight Union	10	Nos.	For Servo line to TCV, I/P, SOV etc
34	1/4 " or 1/2 " tubing	12	Mtrs	For pilot line

(SIGNATURE AND COMPANY SEAL OF BIDDER)

Annexure-VI (C)

Bill Of Material (BOM) - Electronic Burner Management System for each package**Note: This is a reference BoM only.**

SL. NO.	DESCRIPTION	QTY	UNIT	REMARKS
35	SMPS	1	No	230 VAC to 24 VDC, 20A
36	Flame Proof Junction Box with accessories	1	No	
37	Cable Gland 1/2"	10	Nos.	
38	Cable gland 3/4"	4	Nos.	
39	Cable gland 1"	2	Nos.	
40	Signal Cable 1.5 mm ² , 4 core	200	Mtrs	
41	Signal Cable 1.5 mm ² , 16 core	30	Mtrs	
42	Thermocouple cable	30	Mtrs	

(SIGNATURE AND COMPANY SEAL OF BIDDER)

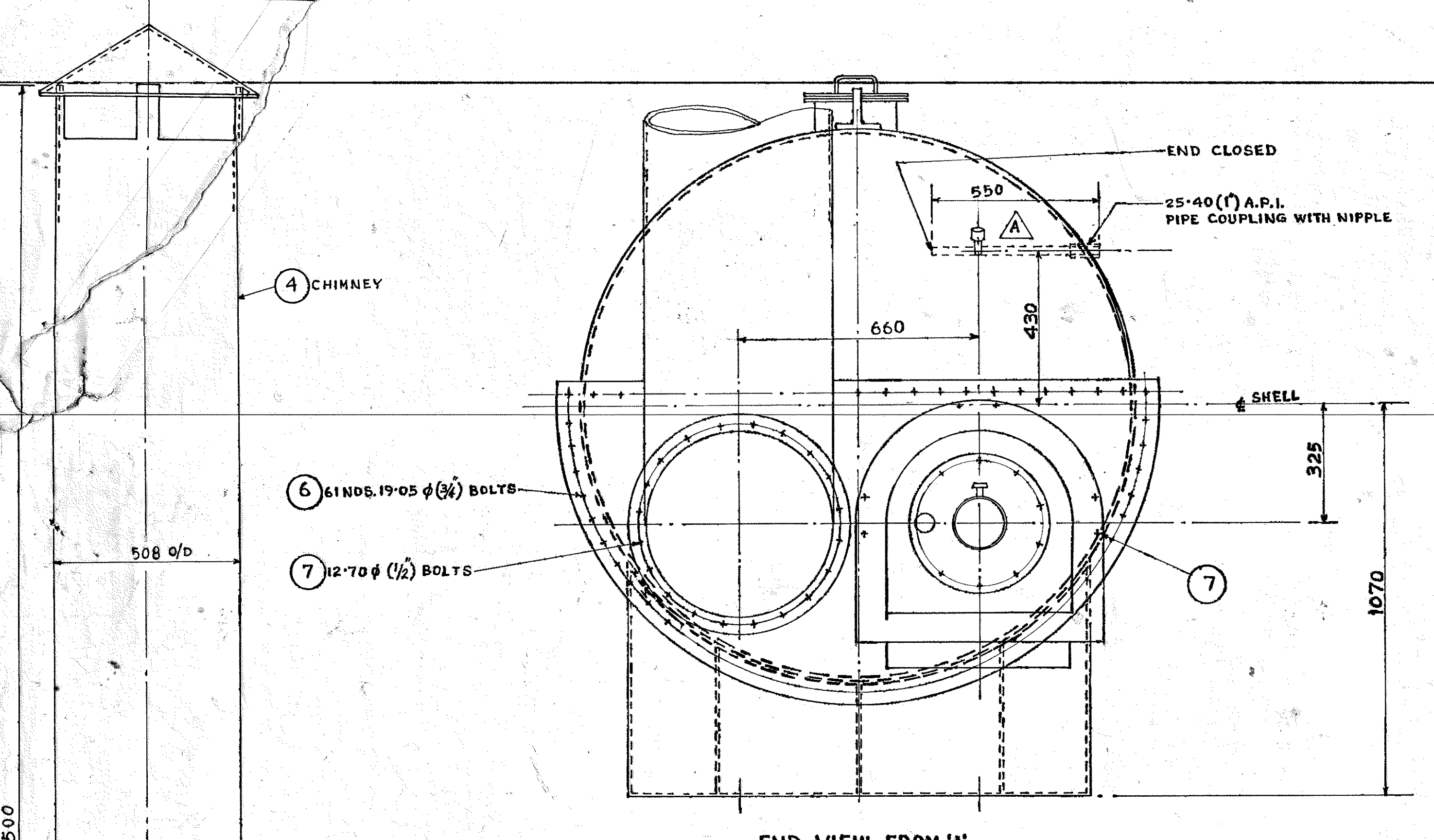

END VIEW FROM 'A'

MATERIAL LIST				DRG. NO. OIL/	
COL. A	ITEM NO.	DESCRIPTION	DRG. REF.	CAT. NO./MAT. SUPPLIERS REF.	REMARKS
1	1	SHELL SUB ASSY	DRG. NO. OIL/2671		
1	2	HEADER PLATE WITH COIL BUNDLE	DRG. NO. OIL/2051/A		
1	3	HEADER PLATE WITH FIRE TUBE	DRG. NO. OIL/2672		
1	4	CHIMNEY			
1	5	FIRE BOX			
122	6	19-05 (3/4) φ STEEL BOLTS X 50 LG. WITH NUTS B.S.W.		M.S. (D.S. 216)	
26	7	1/2-70 (1/2) φ STEEL BOLTS X 50 LG. WITH NUTS B.S.W.		"	
2	8	RUBBER GASKET 902 X 1660 X 3 TK.		NEOPRENE	CUT TO SHAPE
1	9	PERMANITE GASKET 685 O/D X 488 I/D X 3-20 TK.		IS: 2712 GYA/S	
1	10	" " 610 O/D X 488 I/D X 3-20 TK.		"	

COL. 'A' ASSEMBLED TOGETHER MAKES A COMPLETE INDIRECT HEATER.

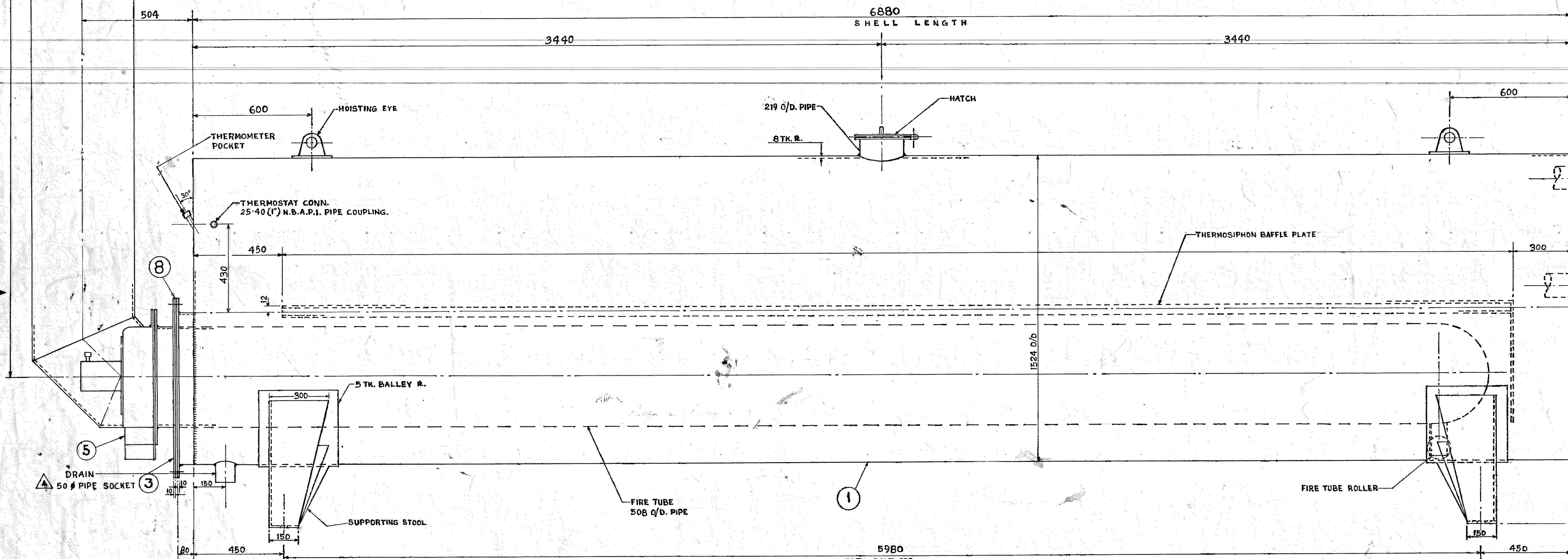

ELEVATION

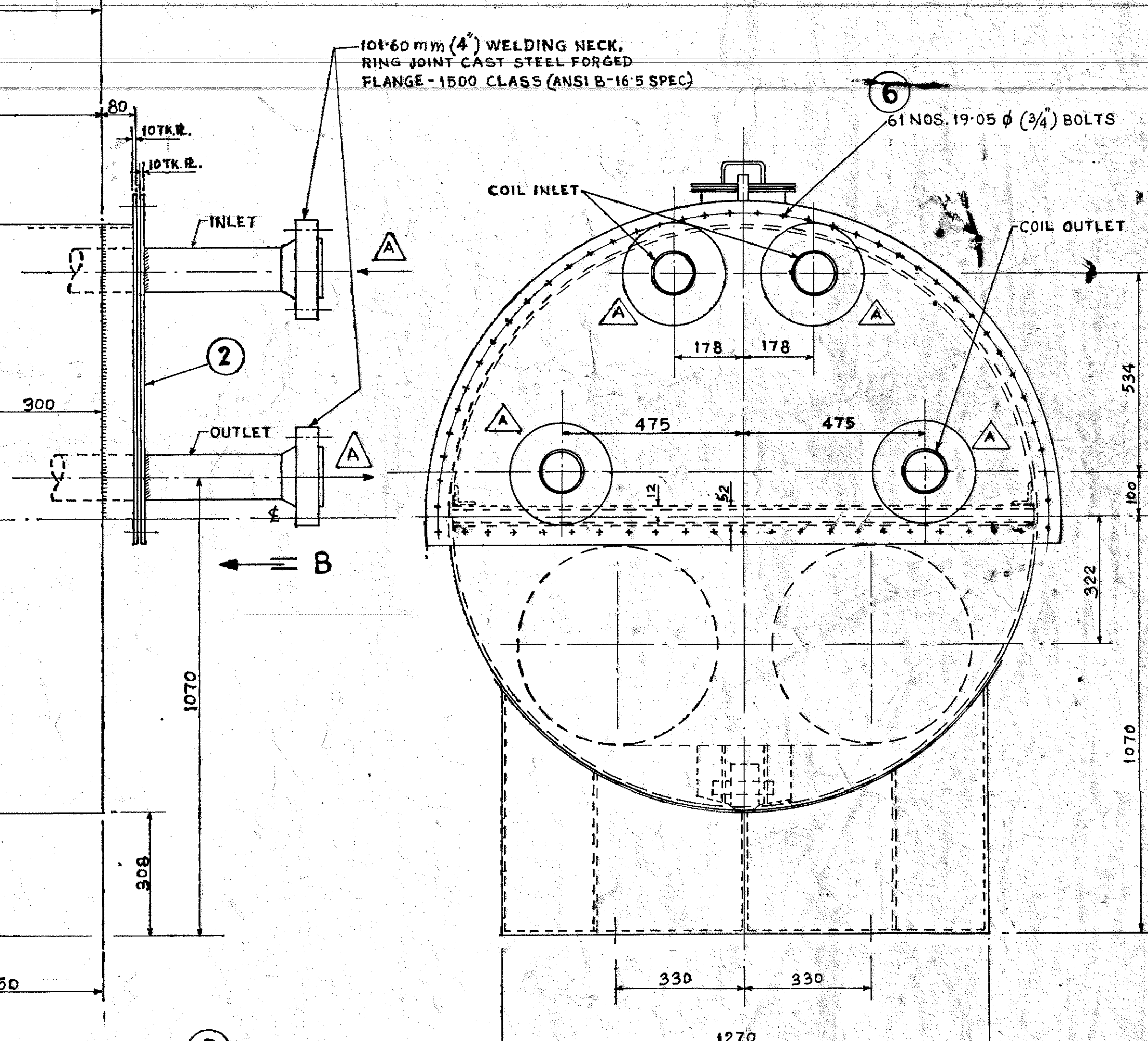

END VIEW FROM 'B'

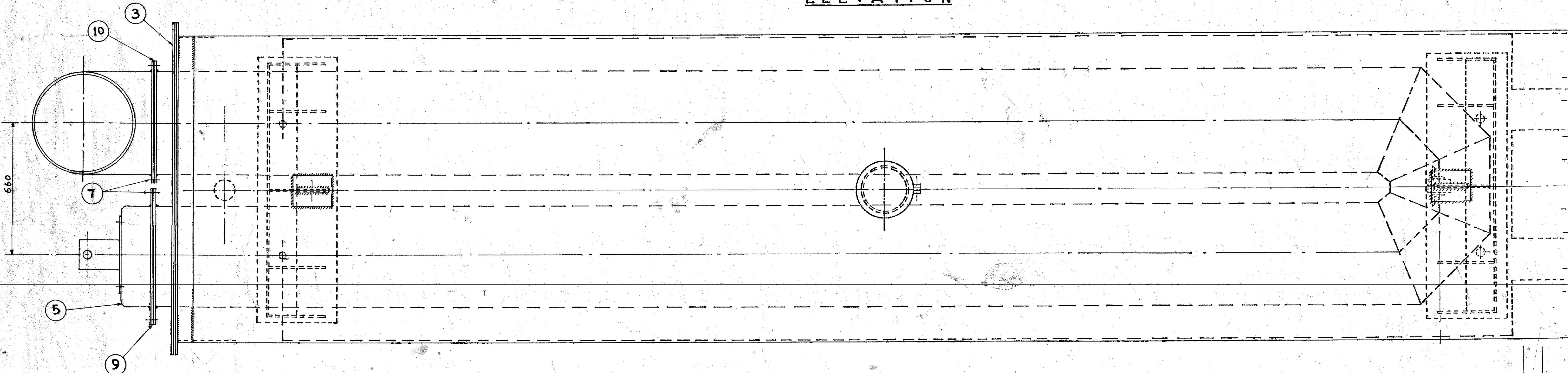

PLAN

- REFERENCE DRAWINGS:
1. SHELL SUB ASSEMBLY - DRG. NO. OIL/2671.
 2. FIRE TUBE & CHIMNEY - " OIL/2672.
 3. HEADER R. WITH COIL BUNDLE - DRG. NO. OIL/2051/A.
 4. FOR FOUNDATION DETAIL - SK. NO. OIL/3205

HEATING CAPACITY - 0-88 X 10⁶ W.

TRACED ON 28.7.98.

OIL INDIA LIMITED DRAWING OFFICE DULIAJAN		NAME	DATE
DESIGNED	5/31	27.12.78	
DRAWN	5/31	28.7.98	
TRACED	5/31		
CHECKED	5/31		
APPROVED	5/31		
TITLE BATH TYPE INDIRECT HEATER 1524 O/D X 6880 LG. GEN. ARRGT.		DRG. NO.	OIL/2670

ALL DIMENSIONS IN MILLIMETRE

MODIFIED AS PER LETTER NO. CE/P/11/AR/35/10-21/11/94
REV. DATE FORS
APPROVED

BURNER MANAGEMENT SYSTEM

- TAHH
- PAHH
- PALL
- FALL
- TIC

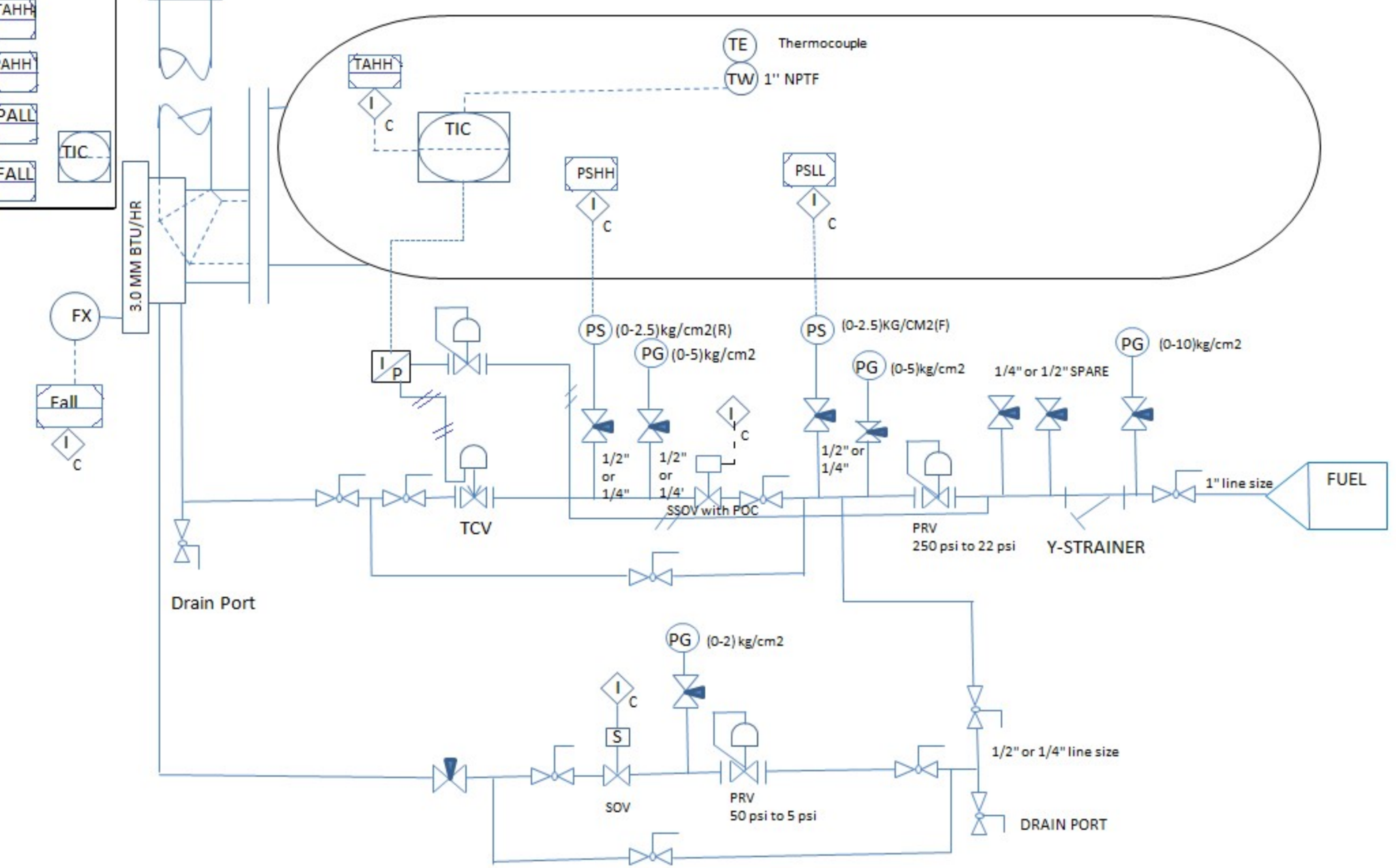



भारत का राजपत्र The Gazette of India

असाधारण

EXTRAORDINARY

भाग II—खण्ड 3—उप-खण्ड (i)

PART II—Section 3—Sub-section (i)

प्राधिकार से प्रकाशित

PUBLISHED BY AUTHORITY

सं. 898]

नई दिल्ली, बृहस्पतिवार, नवम्बर 2, 2017/कार्तिक 11, 1939

No. 898]

NEW DELHI, THURSDAY, NOVEMBER 2, 2017/KARTIKA 11, 1939

श्रम एवं रोजगार मंत्रालय

(खान सुरक्षा महानिदेशालय)

अधिसूचना

नई दिल्ली, 18 अक्तूबर, 2017

सा.का.नि. 1359(अ).— तेल खान विनियम, 2017 के विनियम 107 के उप-विनियम (2) के अधीन प्रदत्त शक्तियों का प्रयोग करते हुए, मैं प्रशान्त कुमार सरकार, मुख्य खान निरीक्षक जो खान सुरक्षा महानिदेशक के रूप में भी पदनामित हूँ, एतद्द्वारा तेल खानों के जोन-1 या जोन-2 जोखिममय क्षेत्रों में उपयोग किये जाने वाले वैद्युत साधित्र, उपस्कर, मशीनरी या अन्य सामग्रियों के लिए निम्नलिखित मानकों को सामान्य आदेश के द्वारा अधिसूचित करता हूँ।

क्र. सं.	भारतीय मानक शीर्षक	भारतीय मानक	आईईसी मानक	समतुल्य मानक
1	वायुमंडल में विस्फोटक गैस के लिए विद्युत उपकरण – सामान्य आवश्यकता	आईएस/आईईसी 60079-0:2011 आईएस/आईईसी 60079-0:2007	आईईसी 60079-0:2011	ईएन 60079-0:2011
2	वायुमंडल में विस्फोटक गैस के लिए विद्युत उपकरण –ऊष्मारोधी आवरण "डी"	आईएस/आईईसी 60079-1:2007	आईईसी 60079-1:2007	ईएन 60079-1:2007
3	वायुमंडल में विस्फोटक गैस के लिए विद्युत उपकरण –दबावनुकूलित आवरण "पी"	आईएस/आईईसी 60079-2:2007	आईईसी 60079-2:2007	ईएन 60079-2:2007
4	वायुमंडल में विस्फोटक गैस के लिए विद्युत उपकरण – पाउडर भरने "क्यू"	आईएस/आईईसी 60079-5:2007	आईईसी 60079-5:2007	ईएन 60079-5:2007

क्र. सं.	भारतीय मानक शीर्षक	भारतीय मानक	आईईसी मानक	समतुल्य मानक
5	वायुमंडल में विस्फोटक गैस के लिए विद्युत उपकरण –तेल विसर्जन “ओ”	आईएस/आईईसी 60079-6:2007	आईईसी 60079-6:2007	ईएन 60079-6:2007
6	वायुमंडल में विस्फोटक गैस के लिए विद्युत उपकरण –सुरक्षा में वृद्धि “ई”	आईएस/आईईसी 60079-7:2006	आईईसी 60079-7:2006	ईएन 60079-7:2007
7	वायुमंडल में विस्फोटक गैस के लिए विद्युत उपकरण – आंतरिक सुरक्षा “आई”	आईएस/आईईसी 60079-11:2006	आईईसी 60079-11:2011	ईएन 60079-11:2012
8	वायुमंडल में विस्फोटक गैस के लिए विद्युत उपकरण –सुरक्षा के प्रकार “एन”	आईएस/आईईसी 60079-15:2010	आईईसी 60079-15:2010	ईएन 60079-15:2010
9	वायुमंडल में विस्फोटक गैस के लिए विद्युत उपकरण –संपुटीकरण “एम”	आईएस/आईईसी 60079-18:2009	आईईसी 60079-18:2009	ईएन 60079-18:2009
10	वायुमंडल में विस्फोटक गैस के लिए विद्युत उपकरण – आंतरिक रूप से सुरक्षित विद्युत प्रणालियाँ	आईएस/आईईसी 60079-25:2010	आईईसी 60079-25:2010	ईएन 60079-25:2010
11	विस्फोटक वायुमंडल – उपकरण संरक्षण स्तर (ईपीएल) के साथ उपकरण	आईएस/आईईसी 60079-26:2006	आईईसी 60079-26:2006	ईएन 60079-26:2006
12	विस्फोटक वायुमंडल – फील्ड बस आंतरिक रूप से सुरक्षित अवधारण (एफआईसीओ)	आईएस/आईईसी 60079-27:2008	आईईसी 60079-27:2008	ईएन 60079-27:2008
13	विस्फोटक वायुमंडल – ऑप्टिकल विकिरण का उपयोग करने वाले उपकरण और ट्रांसमिशन पणाली का संरक्षण	आईएस/आईईसी 60079-28:2006	आईईसी 60079-28:2006	ईएन 60079-28:2006
14	विस्फोटक वायुमंडल – गैस डिटेक्टर-ज्वलनशील गैसों को पता लगाने के लिए खुले रास्तों में प्रदर्शन की आवश्यकता	आईएस/आईईसी 60079-29/ Sec4: 2009	आईईसी 60079-29/Sec4:2009	ईएन 60079-29-4:2007
15	विस्फोटक वायुमंडल – गैस डिटेक्टर-ज्वलनशील गैसों के लिए डिटेक्टरों के प्रदर्शन की आवश्यकता	आईएस/आईईसी 60079-29/ Sec1: 2007	आईईसी 60079-29/Sec1:2007	ईएन 60079-29-1:2007
16	विस्फोटक वायुमंडल – गैस डिटेक्टर-ज्वलनशील गैसों और ऑक्सीजन के लिए डिटेक्टरों के रखरखाव एवं उपयोग का चयन करें	आईएस/आईईसी 60079-29/ Sec2: 2007	आईईसी 60079-29/Sec2:2007	ईएन 60079-29-2:2007
17	विस्फोटक वायुमंडल – विद्युत प्रतिरोध ट्रेस ताप- सामान्य एवं परीक्षण की आवश्यकताएं	आईएस/आईईसी 60079-30/Sec-1: 2007	आईईसी 60079-30/Sec-1:2007	ईएन 60079-30-1:2007
18	विद्युत प्रतिरोध ट्रेस ताप – डिजाइन प्रस्थापना और रखरखाव के लिए प्रयुक्त निर्देशन गाइड	आईएस/आईईसी 60079-30/Sec-2: 2007	आईईसी 60079-30/Sec-2:2007	ईएन 60079-30-2:2010

मानकों का नवीनतम संस्करण तालिका में दिए गए मानकों को प्रतिस्थापित करेगा। उपरोक्त प्रासंगिक मानकों के अनुरूप परीक्षण रिपोर्ट भारत सरकार के प्रयोगशाला या एनएवीएल मान्यता प्राप्त प्रयोगशाला या आईईसीईएक्स मान्यता प्राप्त प्रयोगशाला या एटीईएक्स अधिसूचित निकाय से होगी जो निर्माता की सुविधाओं का हिस्सा नहीं है।

खानों के जोखिममय क्षेत्रों में जोन-1 एवं जोन-2 में प्रयुक्त विद्युत उपकरण, केन्द्रीय विद्युत प्राधिकरण विनियम, 2010 (सुरक्षा और विद्युत आपूर्ति से संबंधित उपाय), (समय-समय पर यथा संशोधित) के प्रावधानों का अनुपालन करेगा।

[फा. सं. एस-29020/60/राजपत्र/2017/वि.मु.]

प्रशान्त कुमार सरकार, मुख्य खान निरीक्षक

MINISTRY OF LABOUR AND EMPLOYMENT

(Directorate General of Mines Safety)

NOTIFICATION

New Delhi, the 18th October, 2017

G.S.R. 1359(E)---- In exercise of the powers conferred on me under Sub-Regulation (2) of 107 of the Oil Mines Regulations, 2017, I, Prasanta Kumar Sarkar, Chief Inspector of Mines also designated as the Director General of Mines Safety notify the following standards by general order for electrical appliance, equipment, machinery or other material that are used or may be used in zone "1" or zone "2" hazardous areas of oil mines.

Sl. No.	TITLE OF INDIAN STANDARDS	INDIAN STANDARDS	IEC STANDARDS	EQUIVALENT STANDARDS
1	Electrical apparatus for explosive gas atmospheres- General requirements	IS/IEC 60079-0: 2011 IS/IEC 60079-0: 2007	IEC 60079-0: 2011	EN 60079-0: 2011
2	Electrical apparatus for explosive gas atmospheres- flameproof enclosure "d"	IS/IEC 60079-1: 2007	IEC 60079-1: 2007	EN 60079-1: 2007
3	Electrical apparatus for explosive gas atmospheres-Pressurized enclosure "p"	IS/IEC 60079-2: 2007	IEC 60079-2: 2007	EN 60079-2: 2007
4	Electrical apparatus for explosive gas atmospheres-Powder filling "q"	IS/IEC 60079-5: 2007	IEC 60079-5: 2007	EN 60079-5: 2007
5	Electrical apparatus for explosive gas atmospheres-Oil immersion "O"	IS/IEC 60079-6: 2007	IEC 60079-6: 2007	EN 60079-6: 2007
6	Electrical apparatus for explosive gas atmospheres-Increased safety "e"	IS/IEC 60079-7: 2006	IEC 60079-7: 2006	EN 60079-7: 2007
7	Electrical apparatus for explosive gas atmospheres-Intrinsic safety "i"	IS/IEC 60079-11: 2006	IEC 60079-11: 2011	EN60079-11: 2012
8	Electrical apparatus for explosive gas atmospheres-type of protection "n"	IS/IEC 60079-15: 2010	IEC 60079-15:2 010	EN 60079-15: 2010
9	Electrical apparatus for explosive gas atmospheres-Encapsulation "m"	IS/IEC 60079-18: 2009	IEC 60079-18: 2009	EN 60079-18: 2009
10	Electrical apparatus for explosive gas atmospheres-Intrinsically safe electrical systems	IS/IEC 60079-25: 2010	IEC 60079-25: 2010	EN 60079-25: 2010
11	Explosive atmospheres-Equipment with equipment protection level (EPL) Ga	IS/IEC 60079-26: 2006	IEC 60079-26: 2006	EN 60079-26 : 2006
12	Explosive atmospheres-Field bus intrinsically safe concept (FISCO)	IS/IEC 60079-27: 2008	IEC 60079-27: 2008	EN 60079-27: 2008

Sl. No.	TITLE OF INDIAN STANDARDS	INDIAN STANDARDS	IEC STANDARDS	EQUIVALENT STANDARDS
13	Explosive atmospheres-Protection of equipment and transmission system using optical radiation	IS/IEC 60079-28: 2006	IEC 60079-28: 2006	EN 60079-28: 2006
14	Explosive atmospheres-Gas detectors-Performance requirements of open path detectors for flammable gases	IS/IEC 60079-29/ Sec4: 2009	IEC 60079-29 / Sec4:2009	EN-60079-29-4: 2007
15	Explosive atmospheres-Gas detectors-Performance requirements of detectors for flammable gases	IS/IEC 60079-29/ Sec1: 2007	IEC 60079-29/Sec1:2007	EN-60079-29-1: 2007
16	Explosive atmospheres-Gas detectors-Selection use and maintenance of detectors for flammable gases and oxygen	IS/IEC 60079-29/ Sec2: 2007	IEC 60079-29 / Sec2:2007	EN-60079-29-2: 2007
17	Explosive atmospheres-Electrical resistance Trace Heating- General and testing requirements	IS/IEC 60079-30 /Sec-1: 2007	IEC 60079-30 /Sec-1:2007	EN-60079-30-1: 2007
18	Electrical resistance Trace Heating-Application guide for design installation and maintenance	IS/IEC 60079-30 /Sec-2: 2007	IEC 60079-30 /Sec-2:2007	EN-60079-30-2: 2010

The latest version of standards shall prevail over the standards given in the table. Test reports conforming to the above relevant standards shall be from an Indian Government Laboratory or NABL accredited laboratory or IECEx accredited laboratory or ATEX notified body, which is not a part of manufacturer's facilities.

The use of electrical apparatus either in Zone-“1” or Zone-“2” hazardous area of the mines shall comply with the provisions of the Central Electricity Authority (Measures relating to Safety and Electric Supply) Regulations, 2010 (as amended from time to time).

[F. No. S-29020/60/Gazette/2017/EHQ]

PRASANTA KUMAR SARKAR, Chief Inspector of Mines

अधिसूचना

नई दिल्ली, 18 अक्टूबर, 2017

सा.का.नि. 1360(अ).—तेल खान अधिनियम, 2017 के विनियम 118 के उप-विनियम (1) के अधीन प्रदत्त शक्तियों का प्रयोग करते हुए, मैं प्रशान्त कुमार सरकार, मुख्य खान निरीक्षक जो खान सुरक्षा महानिदेशक के रूप में भी पदनामित हूँ, एतद्द्वारा तेल खानों के जोखिममय क्षेत्रों में प्रयुक्त किये जाने वाले विद्युत प्रकाश साधित्र के लिए निम्नलिखित मानकों को सामान्य आदेश के द्वारा अधिसूचित करता हूँ।

क्र. सं.	भारतीय मानक शीर्षक	भारतीय मानक	आईईसी मानक	समतुल्य मानक
1	वायुमंडल में विस्फोटक गैस के लिए विद्युत उपकरण – सामान्य आवश्यकता	आईएस/आईईसी 60079-0:2011 आईएस/आईईसी 60079-0:2007	आईईसी 60079-0:2011	ईएन 60079-0: 2011
2	वायुमंडल में विस्फोटक गैस के लिए विद्युत उपकरण –ऊष्मारोधी आवरण “डी”	आईएस/आईईसी 60079-1:2007	आईईसी 60079-1:2007	ईएन 60079-1: 2007

क्र. सं.	भारतीय मानक शीर्षक	भारतीय मानक	आईईसी मानक	समतुल्य मानक
3	वायुमंडल में विस्फोटक गैस के लिए विद्युत उपकरण—सुरक्षा में वृद्धि “ई”	आईएस/आईईसी 60079-7:2006	आईईसी 60079-7:2006	ईएन 60079-2:2007

मानकों का नवीनतम संस्करण तालिका में दिए गए मानकों को प्रतिस्थापित करेगा। उपरोक्त प्रासंगिक मानकों के अनुरूप परीक्षण रिपोर्ट भारत सरकार के प्रयोगशाला या एनएबीएल मान्यता प्राप्त प्रयोगशाला या आईईसीईएक्स मान्यता प्राप्त प्रयोगशाला या एटीईएक्स अधिसूचित निकाय से होगी जो निर्माता की सुविधाओं का हिस्सा नहीं है।

खानों के जोखिममय क्षेत्रों में जोन-1 एवं जोन-2 में प्रयुक्त विद्युत प्रकाश उपकरण, केन्द्रीय विद्युत प्राधिकरण विनियम, 2010 (सुरक्षा और विद्युत आपूर्ति से संबंधित उपाय) (समय-समय पर यथा संशोधित) के प्रावधानों का अनुपालन करेगा।

[फा. सं. एस-29020/60/राजपत्र/2017/वि.मु.]

प्रशान्त कुमार सरकार, मुख्य खान निरीक्षक

NOTIFICATION

New Delhi, the 18th October, 2017

G.S.R. 1360(E).—In exercise of the powers conferred on me under Sub-Regulation (1) of 118 of the Oil Mines Regulations, 2017, I, Prasanta Kumar Sarkar, Chief Inspector of Mines also designated as the Director General of Mines Safety hereby notify the following standards by general order for Electrical lighting apparatus for use in hazardous area of oil mines.

Sl. No.	TITLE OF INDIAN STANDARDS	INDIAN STANDARDS	IEC STANDARDS	EQUIVALENT STANDARDS
1	Electrical apparatus for explosive gas atmospheres- General requirements	IS/IEC 60079-0:2011 IS/IEC 60079-0:2007	IEC 60079-0: 2011	EN 60079-0:2011
2	Electrical apparatus for explosive gas atmospheres- flameproof enclosure “d”	IS/IEC 60079-1:2007	IEC 60079-1: 2007	EN 60079-1:2007
3	Electrical apparatus for explosive gas atmospheres-Increased safety “e”	IS/IEC 60079-7:2006	IEC 60079-7: 2006	EN 60079-7:2007

The latest version of standards shall prevail over the standards given in the table. Test reports conforming to the above relevant standards shall be from an Indian Government Laboratory or NABL accredited laboratory or IECEx accredited laboratory or ATEX notified body, which is not a part of manufacturer’s facilities.

The use of electrical lighting apparatus either in Zone-“1” or Zone-“2” hazardous area of the mines shall comply with the provisions of the Central Electricity Authority (Measures relating to Safety and Electric Supply) Regulations, 2010 (as amended from time to time).

[F. No. S-29020/60/Gazette/2017/EHQ]

PRASANTA KUMAR SARKAR, Chief Inspector of Mines



ऑयल इंडिया लिमिटेड

(भारत सरकार का उद्यम)

Oil India Limited

(A Government of India Enterprise)

MATERIALS DEPARTMENT - FIELD HEAD QUARTERS,
P.O., DULIAJAN, DIBRUGARH DISTRICT, ASSAM – 786602

TEL: (+91) 374 2808613

EMAIL: materials@oilindia.in | f_sathiyaraj@oilindia.in

ANNEXURE-VII

(PART-B)

SPECIAL TERMS

AND

CONDITIONS

(SCC) & MATRIX



Oil India Limited
Materials Department – Field Head Quarters
Duliajan, Assam, India – 786602
 Tel: +91-374-280 8741 | Email: materials@oilindia.in | f_sathiyaraj@oilindia.in
 Website: www.oil-india.com

ANNEXURE-VII
(PART-B) SPECIAL TERMS AND CONDITIONS

TECHNICAL EVALUATION MATRIX FOR (PART-B) SPECIAL TERMS AND CONDITIONS			
(TO BE DULY FILLED IN BY BIDDER AND SIGNED)			
Sl. No.	Description	BIDDER'S RESPONSE	
		(TO BE FILLED BY THE BIDDER)	
		Complied / Not Complied / Not Applicable	Relevant Location of their Bid to support the remarks / compliance
1	The scope of supply and installation shall include Burner Management System (Electronic) with Fuel Train including all accessories for successful commissioning.		
2	The bidder must provide all relevant technical catalogues of the offered make and model of the proposed instruments, BMS controller, SOVs, Hooters and other accessories along with their bid for technical evaluation.		
3	All electronic/electrical instruments and equipment to be used in hazardous area shall fulfil the following:		
(a)	Item shall be of a type and specification conforming to the relevant standards as specified in the Regulation 107(2) of Oil Mines Regulation-2017 and complying the provisions therein.		
(b)	Bidder shall provide documents specifying the type, details of specification, reference of the particular standard, test criteria as per the standards and status of testing, place of testing, copies of test reports from Indian Government Laboratory or NABL accredited laboratory or IECEx accredited laboratory or ATEX notified body which is not a part of manufacture's facilities along with their offer against this tender.		
(c)	In this regard, Bidder may refer OMR-2017, Notification dated 18th October 2017, published in the Gazette of India, under Ministry of Labour and Employment, Directorate General of Mines Safety, published on 2nd November 2017. Copy of the gazette notification shall be attached for reference.		
4	The bidder must categorically confirm in writing that their supplied items will be as per the makes mentioned in point no. A a(16) of the Technical Specification.		

(SIGNATURE COMPANY SEAL OF BIDDER)



Oil India Limited
Materials Department – Field Head Quarters
Duliajan, Assam, India – 786602
 Tel: +91-374-280 8741 | Email: materials@oilindia.in | f_sathiyaraj@oilindia.in
 Website: www.oil-india.com

ANNEXURE-VII**(PART-B) SPECIAL TERMS AND CONDITIONS**

TECHNICAL EVALUATION MATRIX FOR (PART-B) SPECIAL TERMS AND CONDITIONS			
(TO BE DULY FILLED IN BY BIDDER AND SIGNED)			
Sl. No.	Description	BIDDER'S RESPONSE	
		(TO BE FILLED BY THE BIDDER)	
		Complied / Not Complied / Not Applicable	Relevant Location of their Bid to support the remarks / compliance
5	The P&ID diagram of the proposed system shall be submitted to OIL for evaluation purpose. However the same need to be approved from OIL before execution.		
6	230 VAC supply shall be provided by OIL. Necessary rectification to 24 VDC shall be in bidder's scope. Cabling to site will be in bidder's scope.		
7	The successful bidder must supply one (01) hard copy of Operation & Maintenance manual of all the instruments and BMS controller (for each installation).		
8	OIL reserves the right to inspect, test and if necessary reject any part/parts after delivery at site (including incomplete manuals, catalogues, etc.). In case of any fault on the part of the supplier he has to replace/repair at his own cost.		
9	Supply of all necessary accessories & fittings like-pipe, cable tray, Junction Box, Cable gland, cable tie, nut bolt, screw, clamp, etc. required to complete the installation and commission of the BMS is under the scope of the bidder and should be included in their quoted price.		
10	The supplier must submit an undertaking along with the bid that the spares and consumables for the Burner management system shall be available for next six (06) years from the date of successful commissioning.		
11	Since these BMS will be installed with the indirect heaters which are currently in operation, hence minimum downtime will be allowed for the job.		

(SIGNATURE COMPANY SEAL OF BIDDER)



ANNEXURE-VIII

BID REJECTION CRITERIA (BRC)

/

BID EVALUATION CRITERIA (BEC) & MATRIX



Oil India Limited
Materials Department – Field Head Quarters
Duliajan, Assam, India – 786602
 Tel: +91-374-280 8741 | Email: materials@oilindia.in | f_sathiyaraj@oilindia.in
 Website: www.oil-india.com

ANNEXURE-VIII
BID REJECTION CRITERIA / BID EVALUATION CRITERIA

TECHNICAL EVALUATION MATRIX FOR BRC / BEC			
(TO BE DULY FILLED IN BY BIDDER AND SIGNED)			
Sl. No.	Description	BIDDER'S RESPONSE	
		(TO BE FILLED BY THE BIDDER)	
		Complied / Not Complied / Not Applicable	Relevant Location of their Bid to support the remarks / compliance (Reference of Document name / Serial number / Page number of bid for documentary evidence)
<p>The bids shall conform to the specifications and terms & conditions given in the Tender. Bids shall be rejected in case the items offered do not conform to technical specifications and to the respective international/national standards wherever stipulated. Notwithstanding the general conformity of the bids to the stipulated specifications and terms & conditions, the following requirements shall have to be particularly met by the bidders, without which the offer will be considered as non-responsive and rejected. All documents related to BEC/BRC must be submitted along with the technical bid.</p>			
I. BID REJECTION CRITERIA (BRC)			
(A1) TECHNICAL			
1.0	<u>Bidder's Qualification</u>		
1.1.	The bidder shall be the Original Equipment Manufacturer (OEM) of the controller of the Burner Management System or Remote Ignition System used in oil and gas sector.		
	OR		
1.2	The bidder shall be authorized agent / dealer / channel partner/ distributor / supply house of an OEM of the controller of the Burner Management System or Remote Ignition System used in oil and gas sector.		
	Note:		
a)	Bidders other than OEM must submit valid authorization letter from the OEM of the controller of the Burner Management System or Remote Ignition System used in oil and gas sector. The backup warranty for the aforesaid controller in OEM's letter head need to be submitted along with the technical bid.		

(SIGNATURE COMPANY SEAL OF BIDDER)



Oil India Limited
Materials Department – Field Head Quarters
Duliajan, Assam, India – 786602
 Tel: +91-374-280 8741 | Email: materials@oilindia.in | f_sathiyaraj@oilindia.in
 Website: www.oil-india.com

ANNEXURE-VIII

BID REJECTION CRITERIA / BID EVALUATION CRITERIA

TECHNICAL EVALUATION MATRIX FOR BRC / BEC			
(TO BE DULY FILLED IN BY BIDDER AND SIGNED)			
Sl. No.	Description	BIDDER'S RESPONSE	
		(TO BE FILLED BY THE BIDDER)	
		Complied / Not Complied / Not Applicable	Relevant Location of their Bid to support the remarks / compliance (Reference of Document name / Serial number / Page number of bid for documentary evidence)
b)	The Sole Selling Agent/Dealer/ channel partner/ Distributor/Supply House shall categorically confirm in their technical bid that there will be no change of the proposed OEM after submission of the bid.		
2.0	<u>Bidder's Experience</u>		
2.1	In case the bidder is the OEM of the controller of the Burner Management System or Remote Ignition System used in oil and gas sector, then the bidder can either submit their own supply experience or they can submit supply experience of successfully executing their own manufactured ' Similar items ' of value not less than 50% of the tender value (i.e. INR 79,02,691) or tender quantity not less than 50% of the tender quantity (i.e. 3 Nos) through their authorized agent/ dealer/ distributor/ supply house/ channel partner in preceding 05 (five) years (single order) from the original bid closing date of the tender.		
2.2	Bidders other than OEM must have the supply experience of successfully executing at least one order of 'Similar items' of value not less than 50% of the tender value (i.e. INR 79,02,691) or tender quantity not less than 50% of the tender quantity (i.e. 3 Nos) in preceding 05 (five) years from the original bid closing date of the tender.		

(SIGNATURE COMPANY SEAL OF BIDDER)



Oil India Limited
Materials Department – Field Head Quarters
Duliajan, Assam, India – 786602
 Tel: +91-374-280 8741 | Email: materials@oilindia.in | f_sathiyaraj@oilindia.in
 Website: www.oil-india.com

ANNEXURE-VIII
BID REJECTION CRITERIA / BID EVALUATION CRITERIA

TECHNICAL EVALUATION MATRIX FOR BRC / BEC			
(TO BE DULY FILLED IN BY BIDDER AND SIGNED)			
Sl. No.	Description	BIDDER'S RESPONSE	
		(TO BE FILLED BY THE BIDDER)	
		Complied / Not Complied / Not Applicable	Relevant Location of their Bid to support the remarks / compliance (Reference of Document name / Serial number / Page number of bid for documentary evidence)
2.3	<p>In addition to the above clauses (2.1 or 2.2 whichever is applicable), the bidder must have the experience of carrying out installation and commissioning of least one order of 'Similar items' in preceding 05 (five) years from the original bid closing date of the tender.</p> <p>*Similar items mean Electronic Burner Management System (BMS) or Remote Ignition System consisting of minimum Burner Management Controller/ Electrical Ignition System, Pilot Burners and Thermocouple assembly.</p>		
2.4	NOTES TO BIDDER REGARDING EXPERIENCE CRITERIA:		
2.4.1.	Bidder must submit the following documentary evidence in support of previous supply experience as applicable under clause 2.1 or 2.2 above:		
(i)	Copy of Purchase Order /Contract document and		
(ii)	<p>Any one or combination of the following documents that confirms the successful execution of the purchase order / contract :</p> <ul style="list-style-type: none"> - Completion report / performance certificate from the clients, - Bill of lading, - Delivery challan / invoice. - Any other documentary evidence that can substantiate the successful execution of each of the Purchase Order / contract cited above. 		

(SIGNATURE COMPANY SEAL OF BIDDER)



Oil India Limited
Materials Department – Field Head Quarters
Duliajan, Assam, India – 786602
 Tel: +91-374-280 8741 | Email: materials@oilindia.in | f_sathiyaraj@oilindia.in
 Website: www.oil-india.com

ANNEXURE-VIII
BID REJECTION CRITERIA / BID EVALUATION CRITERIA

TECHNICAL EVALUATION MATRIX FOR BRC / BEC			
(TO BE DULY FILLED IN BY BIDDER AND SIGNED)			
Sl. No.	Description	BIDDER'S RESPONSE	
		(TO BE FILLED BY THE BIDDER)	
		Complied / Not Complied / Not Applicable	Relevant Location of their Bid to support the remarks / compliance (Reference of Document name / Serial number / Page number of bid for documentary evidence)
2.4.2.	The following documentary evidence to substantiate the installation & commissioning experience against clause no. 2.3 must be submitted along with the technical bid, failing which the bid shall be treated as incomplete and rejected:		
(a)	Copy of Purchase order/contract awarded by Client.		
(b)	True copies of Original Signed and sealed Completion report/performance certificate from the clients (on Client's/User's official letter head with signature & stamp). OR - Any other documentary evidence that can substantiate the successful execution of the Purchase Order / contract cited above.		
2.5	The date of purchase order/contract need not be within five (05) years preceding the original bid closing date of the tender, but installation & commissioning/ supply of required quantity must be within five (05) years preceding the original bid closing date of this tender.		
2.6	In case of extension to the scheduled Bid Closing date of this tender, if any, the Original scheduled Bid closing Date shall be considered for evaluation of Bids.		
2.7	Against all supporting documents submitted by the bidder along with the technical bid, originals must be kept ready and to be produced for verification of OIL, if called for.		
2.8	The purchase order/ contract must bear the purchase order number/ contract number which clearly indicate the scope of work and technical specifications of the item.		

(SIGNATURE COMPANY SEAL OF BIDDER)



Oil India Limited
Materials Department – Field Head Quarters
Duliajan, Assam, India – 786602
 Tel: +91-374-280 8741 | Email: materials@oilindia.in | f_sathiyaraj@oilindia.in
 Website: www.oil-india.com

ANNEXURE-VIII

BID REJECTION CRITERIA / BID EVALUATION CRITERIA

TECHNICAL EVALUATION MATRIX FOR BRC / BEC			
(TO BE DULY FILLED IN BY BIDDER AND SIGNED)			
Sl. No.	Description	BIDDER'S RESPONSE	
		(TO BE FILLED BY THE BIDDER)	
		Complied / Not Complied / Not Applicable	Relevant Location of their Bid to support the remarks / compliance (Reference of Document name / Serial number / Page number of bid for documentary evidence)
2.9	The experience of the bidder's sister concern/ subsidiary shall not be considered for evaluation.		

(SIGNATURE COMPANY SEAL OF BIDDER)



Oil India Limited
Materials Department – Field Head Quarters
Duliajan, Assam, India – 786602

Tel: +91-374-280 8741 | Email: materials@oilindia.in | f_sathiyaraj@oilindia.in
Website: www.oil-india.com

ANNEXURE-VIII

BID REJECTION CRITERIA / BID EVALUATION CRITERIA

TECHNICAL EVALUATION MATRIX FOR BRC / BEC			
(TO BE DULY FILLED IN BY BIDDER AND SIGNED)			
Sl. No.	Description	BIDDER'S RESPONSE	
		(TO BE FILLED BY THE BIDDER)	
		Complied / Not Complied / Not Applicable	Relevant Location of their Bid to support the remarks / compliance (Reference of Document name / Serial number / Page number of bid for documentary evidence)
<p>The bids shall broadly conform to the specifications and terms and conditions given in this bid document. Bids shall be rejected in case the items offered do not conform to required parameters stipulated in the technical specifications and to the respective international/national standards wherever stipulated. Notwithstanding the general conformity of the bids to the stipulated specifications and terms and conditions, the following requirements will have to be particularly met by the Bidders without which the same will be considered as non-responsive and rejected.</p>			
I. BID REJECTION CRITERIA (BRC)			
(B) FINANCIAL			
1.0	Annual Turnover:		
	The bidder shall have an annual financial turnover of minimum 50% of the tender value (i.e. INR 79,02,691) during any of the preceding 03 (three) financial years reckoned from the original bid closing date, irrespective of whether their bid is for all the tendered items or not.		
2.0	"Net Worth" of the bidder should be positive for the financial/accounting year just preceding to the original bid closing date of the tender i.e. (FY 2024-25) .		
3.0	Considering the time required for preparation of Financial Statements, if the last date of preceding financial / accounting year falls within the preceding six months reckoned from the original bid closing date and the Financial Statements of the preceding financial / accounting year are not available with the bidder, then the financial turnover of the previous three financial / accounting years excluding the preceding financial / accounting year will be considered. In such cases, the Net worth of the previous financial / accounting year excluding the preceding financial / accounting year will be considered.		

(SIGNATURE COMPANY SEAL OF BIDDER)



Oil India Limited
Materials Department – Field Head Quarters
Duliajan, Assam, India – 786602

Tel: +91-374-280 8741 | Email: materials@oilindia.in | f_sathiyaraj@oilindia.in
Website: www.oil-india.com

ANNEXURE-VIII

BID REJECTION CRITERIA / BID EVALUATION CRITERIA

TECHNICAL EVALUATION MATRIX FOR BRC / BEC			
(TO BE DULY FILLED IN BY BIDDER AND SIGNED)			
Sl. No.	Description	BIDDER'S RESPONSE	
		(TO BE FILLED BY THE BIDDER)	
		Complied / Not Complied / Not Applicable	Relevant Location of their Bid to support the remarks / compliance (Reference of Document name / Serial number / Page number of bid for documentary evidence)
	However, the bidder has to submit an affidavit/undertaking certifying that 'the balance sheet/Financial Statements for the financial year (As the case may be) has actually not been audited as on original bid closing date' (Proforma - A).		
	Note:		
(a)	For proof of Annual Turnover & Net worth any one of the following documents must be submitted along with the technical bid:		
	(i) A certificate issued by a practicing Chartered/ Cost Accountant (with Membership Number and Firm Registration Number), certifying the Annual Turnover & Net worth as per format prescribed in (PROFORMA - B).		
	OR		
	(ii) Financial Statements (Balance Sheet & Profit & Loss account along with all the schedules/notes forming part of the Balance sheet & Profit and Loss Account) audited by the auditors appointed under the statute like Companies Act etc. wherever applicable. In cases where the bidding/ supporting company (as applicable) are not required to prepare Audited Financial Statements as per the Law of the Land of the country of the bidding/supporting company as applicable, the bidder shall provide documentary evidence for the same along with a certificate from a practicing Chartered Accountant or equivalent to this effect. The bidder must also submit the financial statement as per the accounting standards of the country of the bidding/supporting company as the case may be, duly certified by the practicing-chartered accountant or equivalent.		

(SIGNATURE COMPANY SEAL OF BIDDER)



Oil India Limited
Materials Department – Field Head Quarters
Duliajan, Assam, India – 786602
 Tel: +91-374-280 8741 | Email: materials@oilindia.in | f_sathiyaraj@oilindia.in
 Website: www.oil-india.com

ANNEXURE-VIII
BID REJECTION CRITERIA / BID EVALUATION CRITERIA

TECHNICAL EVALUATION MATRIX FOR BRC / BEC			
(TO BE DULY FILLED IN BY BIDDER AND SIGNED)			
Sl. No.	Description	BIDDER'S RESPONSE	
		(TO BE FILLED BY THE BIDDER)	
		Complied / Not Complied / Not Applicable	Relevant Location of their Bid to support the remarks / compliance (Reference of Document name / Serial number / Page number of bid for documentary evidence)
(b)	In case the bidder is a Central Govt. Organization/PSU/State Govt. Organization/Semi-State Govt. Organization or any other Central/State Govt. Undertaking, where the auditor is appointed only after the approval of Comptroller and Auditor General of India and the Central Government, their certificates may be accepted even though FRN is not available. However, bidder to provide documentary evidence for the same.		
4.0	In case the Audited Balance Sheet and Profit & Loss Account submitted along with the bid are in currencies other than INR or US\$, the bidder shall have to convert the figures in equivalent INR, considering the prevailing conversion rate on the date of Balance Sheet and Profit & Loss Account. A Chartered Account (CA) certificate is to be submitted by the bidder regarding converted figures in equivalent INR.		
5.0	In case the Bidder is subsidiary company (should be 100% owned subsidiary of the parent/ultimate parent/holding company) who does not meet financial criteria by itself and submits its bid based on the strength of parent/ultimate parent/holding company, then following documents need to be submitted:		
	i) Turnover of the parent/ultimate parent/holding company should be in line with Para 1.0 above.		
	ii) Net Worth of the parent/ultimate parent/holding company should be positive in line with Para 2.0 above.		

(SIGNATURE COMPANY SEAL OF BIDDER)



Oil India Limited
Materials Department – Field Head Quarters
Duliajan, Assam, India – 786602
 Tel: +91-374-280 8741 | Email: materials@oilindia.in | f_sathiyaraj@oilindia.in
 Website: www.oil-india.com

ANNEXURE-VIII

BID REJECTION CRITERIA / BID EVALUATION CRITERIA

TECHNICAL EVALUATION MATRIX FOR BRC / BEC			
(TO BE DULY FILLED IN BY BIDDER AND SIGNED)			
Sl. No.	Description	BIDDER'S RESPONSE	
		(TO BE FILLED BY THE BIDDER)	
		Complied / Not Complied / Not Applicable	Relevant Location of their Bid to support the remarks / compliance (Reference of Document name / Serial number / Page number of bid for documentary evidence)
	iii) Corporate Guarantee (Proforma - C) on parent/ultimate parent/holding company's company letter head signed by an authorized official undertaking that they would financially support their wholly owned subsidiary company for executing the project/job in case the same is awarded to them.		
	iv) Documents to substantiate that the bidder is as 100% subsidiary of the parent/ultimate parent / holding company.		

(SIGNATURE COMPANY SEAL OF BIDDER)



Oil India Limited
Materials Department – Field Head Quarters
Duliajan, Assam, India – 786602
 Tel: +91-374-280 8741 | Email: materials@oilindia.in | f_sathiyaraj@oilindia.in
 Website: www.oil-india.com

ANNEXURE-VIII**BID REJECTION CRITERIA / BID EVALUATION CRITERIA**

TECHNICAL EVALUATION MATRIX FOR BRC / BEC			
(TO BE DULY FILLED IN BY BIDDER AND SIGNED)			
Sl. No.	Description	BIDDER'S RESPONSE	
		(TO BE FILLED BY THE BIDDER)	
		Complied / Not Complied / Not Applicable	Relevant Location of their Bid to support the remarks / compliance (Reference of Document name / Serial number / Page number of bid for documentary evidence)
<p>The bids shall broadly conform to the specifications and terms and conditions given in this bid document. Bids shall be rejected in case the items offered do not conform to required parameters stipulated in the technical specifications and to the respective international/national standards wherever stipulated. Notwithstanding the general conformity of the bids to the stipulated specifications and terms and conditions, the following requirements will have to be particularly met by the Bidders without which the same will be considered as non-responsive and rejected.</p>			
I. BID REJECTION CRITERIA (BRC)			
(C) COMMERCIAL			
1.0	Bids are invited under SINGLE STAGE TWO BID SYSTEM . Bidders should upload Techno-Commercial Bid (Unpriced Bid) and Priced Bid separately at the designated fields assigned in GeM Portal. Please note that no price details should be furnished in the Technical (i.e. Unpriced) bid. The “Unpriced Bid” shall contain all techno-commercial details except the prices/costs. Bidder not complying with above submission procedure will be rejected.		
2.0	The prices/rates offered against the tender must remain firm through delivery and not subject to variation on any account. A bid submitted with an adjustable price condition shall be treated as non-responsive and rejected. No discount whatsoever should be quoted separately. Rates/prices quoted must be net of all discounts.		
3.0	Bids received in physical form shall be rejected (except the documents specifically called for in hard copies, if any). Also, modifications to bids received after the bid closing date & time shall not be entertained.		
4.0	Bids containing incorrect / false / misleading statement(s) shall be rejected.		
5.0	The validity of the bid shall be a minimum of 120 days from the date of actual Bid Closing Date. Bids with lesser validity shall be straightway rejected.		

(SIGNATURE AND SEAL OF BIDDER)



Oil India Limited
Materials Department – Field Head Quarters
Duliajan, Assam, India – 786602

Tel: +91-374-280 8741 | Email: materials@oilindia.in | f_sathiyaraj@oilindia.in
Website: www.oil-india.com

ANNEXURE-VIII**BID REJECTION CRITERIA / BID EVALUATION CRITERIA**

TECHNICAL EVALUATION MATRIX FOR BRC / BEC			
(TO BE DULY FILLED IN BY BIDDER AND SIGNED)			
Sl. No.	Description	BIDDER'S RESPONSE	
		(TO BE FILLED BY THE BIDDER)	
		Complied / Not Complied / Not Applicable	Relevant Location of their Bid to support the remarks / compliance (Reference of Document name / Serial number / Page number of bid for documentary evidence)
6.0	Bidders must confirm that goods/materials to be supplied against the order arising out of this tender shall be of recent make, unused, of the best quality & workmanship and free from defects. The Bidder must undertake to stand guaranteed for the materials as called for in the tender. Defective goods/materials rejected by OIL, whether the entire lot or part thereof, shall be replaced immediately by the supplier at the supplier's expenses at no extra cost to OIL.		
7.0	Successful bidder will be required to furnish Performance Bank Guarantees as below:		
	(i) PBG @ 5 % of cost for Materials during warranty period to be submitted after receipt of PO. The Performance Security must be valid for 3 (three) months beyond the Warranty period indicated in the Purchase Order/contract agreement.		
	(ii) The Performance Security must be valid for a period as called for in the tender document. Bidder must confirm the same in their Technical Bid. Offers not complying with this clause will be rejected.		
8.0	Bids must be accompanied by Bid Security for the amount as mentioned in the tender document and shall be in the prescribed format (PROFORMA – G (A)) if submitted in the form of Bank Guarantee (BG). Bid Security may also be paid through online payment mode. Bid Security must be submitted within the scheduled Bid Closing date and time of the Tender. The amount of Bid Security (EMD) must be strictly as specified in the tender document.		

(SIGNATURE AND SEAL OF BIDDER)



Oil India Limited
Materials Department – Field Head Quarters
Duliajan, Assam, India – 786602
 Tel: +91-374-280 8741 | Email: materials@oilindia.in | f_sathiyaraj@oilindia.in
 Website: www.oil-india.com

ANNEXURE-VIII**BID REJECTION CRITERIA / BID EVALUATION CRITERIA**

TECHNICAL EVALUATION MATRIX FOR BRC / BEC			
(TO BE DULY FILLED IN BY BIDDER AND SIGNED)			
Sl. No.	Description	BIDDER'S RESPONSE	
		(TO BE FILLED BY THE BIDDER)	
		Complied / Not Complied / Not Applicable	Relevant Location of their Bid to support the remarks / compliance (Reference of Document name / Serial number / Page number of bid for documentary evidence)
8.0	Bid Security if submitted in the form of BG/e-PBG must be valid at least for a period of 6 months from the date of original bid closing date of the tender. Bid shall be rejected without further reference, if the Bid Security (EMD) is not received strictly as above, except where exempted. OIL will not assume any responsibility whatsoever for submission of deficient/faulty Bid Security or for delay/non-delivery of the same.		
9.0	Bid must be uploaded together with the Integrity Pact (If applicable against the tender) and the same must be duly signed digitally. If any bidder refuses to sign Integrity Pact or declined to submit Integrity Pact, their bid shall be rejected straightway.		
10.0	Bidders shall accept and comply with the following clauses as given in the Bid Document, failing which bid shall be liable for rejection:		
	(i) Firm price		
	(ii) EMD / Bid Bond / Bid Security Declaration		
	(iii) Scope of work		
	(iv) Specifications		
	(v) Price Schedule		
	(vi) Delivery / Completion Schedule		
	(vii) Period of Validity of Bid		
	(viii) Liquidated Damages		
	(ix) Performance Bank Guarantee / Security deposit		
	(x) Guarantee of material / work		
	(xi) Arbitration / Resolution of Dispute		
	(xii) Force Majeure		
	(xiii) Applicable Laws		
	(xiv) Integrity Pact, if applicable		

(SIGNATURE AND SEAL OF BIDDER)



Oil India Limited
Materials Department – Field Head Quarters
Duliajan, Assam, India – 786602

Tel: +91-374-280 8741 | Email: materials@oilindia.in | f_sathiyaraj@oilindia.in
Website: www.oil-india.com

ANNEXURE-VIII**BID REJECTION CRITERIA / BID EVALUATION CRITERIA**

TECHNICAL EVALUATION MATRIX FOR BRC / BEC			
(TO BE DULY FILLED IN BY BIDDER AND SIGNED)			
Sl. No.	Description	BIDDER'S RESPONSE	
		(TO BE FILLED BY THE BIDDER)	
		Complied / Not Complied / Not Applicable	Relevant Location of their Bid to support the remarks / compliance (Reference of Document name / Serial number / Page number of bid for documentary evidence)
	<p>(xv) Any other condition specifically mentioned in the tender documents elsewhere that non-compliance of the clause lead to rejection of the bid.</p> <p>However, OIL reserves the sole right to decide on acceptance / rejection of any deviation to tendered requirements by bidder.</p>		
11.0	A bid shall be rejected straightway if it does not conform to any one of the following clauses:		
	a) Validity of bid shorter than the validity indicated in the Tender.		
	b) In case the party refuses to sign Integrity Pact.		
	c) Original Bid Security not received within the stipulated date & time mentioned in the Tender.		
	d) Bid Security with : (i) Validity shorter than the validity indicated in Tender and/or (ii) Bid Security amount lesser than the amount indicated in the Tender.		
12	APPLICABILITY OF BANNING POLICY OF OIL INDIA LIMITED		
	OIL's Banning Policy, 2023 will be applicable against the tender (and order in case of award) to deal with any agency (bidder/contractor/supplier/ vendor/service provider) who commits deception, default, fraud or indulged in other misconduct of whatsoever nature in the tendering process and/or order execution processes.		

(SIGNATURE AND SEAL OF BIDDER)



Oil India Limited
Materials Department – Field Head Quarters
Duliajan, Assam, India – 786602

Tel: +91-374-280 8741 | Email: materials@oilindia.in | f_sathiyaraj@oilindia.in
Website: www.oil-india.com

ANNEXURE-VIII

BID REJECTION CRITERIA / BID EVALUATION CRITERIA

TECHNICAL EVALUATION MATRIX FOR BRC / BEC			
(TO BE DULY FILLED IN BY BIDDER AND SIGNED)			
Sl. No.	Description	BIDDER'S RESPONSE	
		(TO BE FILLED BY THE BIDDER)	
		Complied / Not Complied / Not Applicable	Relevant Location of their Bid to support the remarks / compliance (Reference of Document name / Serial number / Page number of bid for documentary evidence)
	The bidders who are on Holiday/Banning/Suspension list of OIL on due date of submission of bid/ during the process of evaluation of the bids, the offers of such bidders shall not be considered for bid opening/evaluation/award. If the bidding documents were issued inadvertently/downloaded from website, the offers submitted by such bidders shall also not be considered for bid opening/evaluation/ Award of Work.		
12.1	The bidder shall submit an undertaking/declaration as per PROFORMA- N confirming that they have read and understood OIL's Banning Policy and that, neither they nor any of their allied concerns or partners or associates or directors, or proprietors involved in any capacity, are currently on OIL's Holiday/Banning List. Further, the bidder shall confirm that neither they nor any of their aforementioned entities have, during the last three years, been involved in any transgression with any company conforming to the Transparency International (TI) approach or with any Public Sector Enterprise of India that could justify exclusion from the tender process. The bidder shall also disclose details of all such allied entities, if any, as required under the Banning Policy. The bidder shall fill up and submit proforma of declaration of Blacklisting / Holiday Listing/ NCLT / NCLAT /DRT /DRAT/ COURT RECEIVERSHIP/ LIQUIDATION (as per Proforma- N) along with the technical bid).		
12.2	The bidder shall fill up and submit proforma of Undertaking on Acceptance of OIL's 'Banning Policy' (As per Proforma-T) along with the technical bid).		

(SIGNATURE AND SEAL OF BIDDER)



Oil India Limited
Materials Department – Field Head Quarters
Duliajan, Assam, India – 786602
 Tel: +91-374-280 8741 | Email: materials@oilindia.in | f_sathiyaraj@oilindia.in
 Website: www.oil-india.com

ANNEXURE-VIII**BID REJECTION CRITERIA / BID EVALUATION CRITERIA**

TECHNICAL EVALUATION MATRIX FOR BRC / BEC			
(TO BE DULY FILLED IN BY BIDDER AND SIGNED)			
Sl. No.	Description	BIDDER'S RESPONSE	
		(TO BE FILLED BY THE BIDDER)	
		Complied / Not Complied / Not Applicable	Relevant Location of their Bid to support the remarks / compliance (Reference of Document name / Serial number / Page number of bid for documentary evidence)
13	DOCUMENT VERIFICATION (If applicable) :		
	Oil India Limited (OIL) has engaged Independent Inspection Agencies to verify and certify of various documents required against BEC/BRC of the tender: (Details already provided in Clause 37.0 of (PART-A) - SPECIAL CONDITIONS OF CONTRACT (SCC) of Tender)		
13.1	The Bidders have to get the various documents required against BEC/BRC of the tender verified and certified (signed & stamped on each page) by anyone of the above Independent Inspection Agencies and submit the duly certified documents along with the Inspection Certificate issued by the Inspection Agencies as part of their Technical Bids. It may be noted that the scope of inspection is primarily to verify the authenticity of the documents being submitted as part of the bid. All Charges of the Third-party Independent Inspection Agencies towards verification of bidder's documents and certification thereof shall be borne by the respective bidders and Payments on account of above inspection, verification and certification shall be made directly by the Bidder to the Inspection Agency(s). OIL will not be responsible for any payment dispute between Bidders and Third-Party Inspection Agencies.		

(SIGNATURE AND SEAL OF BIDDER)



Oil India Limited
Materials Department – Field Head Quarters
Duliajan, Assam, India – 786602
 Tel: +91-374-280 8741 | Email: materials@oilindia.in | f_sathiyaraj@oilindia.in
 Website: www.oil-india.com

ANNEXURE-VIII**BID REJECTION CRITERIA / BID EVALUATION CRITERIA**

TECHNICAL EVALUATION MATRIX FOR BRC / BEC			
(TO BE DULY FILLED IN BY BIDDER AND SIGNED)			
Sl. No.	Description	BIDDER'S RESPONSE	
		(TO BE FILLED BY THE BIDDER)	
		Complied / Not Complied / Not Applicable	Relevant Location of their Bid to support the remarks / compliance (Reference of Document name / Serial number / Page number of bid for documentary evidence)
13.2	As mentioned above, Bidder(s) have to submit the verified documents and the duly certified Inspection Certificate by the Inspection Agencies along with the Technical Bids. Bid submitted with un-verified supporting documents shall not be normally considered. However, in case a bidder submits its bid along with all relevant supporting documents against BEC/BRC without getting all/some of them verified by the designated Independent Inspection agency, such bid can be provisionally considered provided it is accompanied by an Undertaking by the Bidder on their official letterhead to submit the duly verified copies/verification certificate within seven (7) days of actual bid opening. Company will neither send any reminder nor seek any clarification in this regard from such bidders, and the bid will be rejected outright if the bidder fails to submit the verified copies/verification certificate within seven (7) days of actual bid opening at its own risk and responsibility. If a bidder does not submit the undertaking towards submission of third-party certification within 7 days from date of Bid Closing date, but certified document reaches us within the cut-off date of above seven (7) days, then such bids shall be considered.		
13.3	An Undertaking from Independent Inspection Agencies for Document Verification as per (Proforma – U) should be submitted along with the technical bid.		

(SIGNATURE AND SEAL OF BIDDER)