



ऑयल इंडिया लिमिटेड  
(भारत सरकार का उद्यम)

OIL INDIA LIMITED  
(A GOVT. OF INDIA ENTERPRISE)  
CONTRACTS DEPARTMENT  
PIPELINE HEADQUARTERS  
GUWAHATI – 781171, ASSAM  
E-mail: contracts\_phq@oilindia.in

**BID DOCUMENT**  
**WORKS CONTRACT**  
**Tender NO. : CGI7847P25**

**Maintenance of OFC cable and other Telecom activities for a period of two years extendable by another one year upon review under PS5 Sector (ROW Chainage PLKM 352-497 & Spur Line PHQ - GHY Refinery Termianl)**

**OIL INDIA LIMITED  
(A Government of India Enterprise)  
CONTRACTS DEPARTMENT, PHQ  
P.O. Udayan Vihar- 781171, Guwahati, ASSAM**

**FORWARDING LETTER****WORKS CONTRACT**

OIL INDIA LIMITED (OIL) invites Bids through its E-Procurement portal "<https://etender.srm.oilindia.in/irj/portal>" for the following services under **Single Stage Single Bid System**.

<b>1.0 IFB No.</b>	<b>CGI7847P25</b>
Service Requirement	<b>Maintenance of OFC cable and other Telecom activities for a period of two years extendable by another one year upon review under PS5 Sector(ROW Chainage PLKM 352-497 &amp; Spur Line PHQ - GHY Refinery Termianl)</b>
Cost of Bid Document	<b>NIL</b>
Bid Security(EMD)	<b>INR 1,31,700.00</b>
Period of Sale of Bid Document/Issue of User ID & Password	<b>As per online data</b>
Bid Closing /Opening Date & Time	<b>As per online data</b>

2.0 For participation, the application(s) on applicant's letter pad with a request for USER ID & PASSWORD is to be submitted /sent to reach the **Office of GM(C&P), Contracts Department, Pipeline Head Quarter, Oil India Limited, P.O. Udayan Vihar, Assam-781171** within the period of sale (inclusive both the days i.e. start date & end date) of Bid document.

***Alternatively, applicants already having User ID & Password for OIL's E-procurement portal can register against the IFB.***

In case the Bidder(s) send their application for Bid Documents in sealed envelopes, the following must be super scribed on the envelope along with the name & registered postal address of the bidder in typed format or in clear legible handwriting:

"Application- IFB No.: CGI7847P25

Description of Services: **Maintenance of OFC cable and other Telecom activities for a period of two years extendable by another one year upon review under PS5 Sector(ROW Chainage PLKM 352-497 & Spur Line PHQ - GHY Refinery Termianl)** Amongst others, the Bidder(s) must also provide the following information in the application for request for Bid documents: (i) Valid

e-mail ID (ii) Registered Postal Address with PIN code (iii) Vendor Code with OIL (if available) (iv) Mobile No. /Telephone No/Fax No.

- 2.1 No physical Bid documents will be provided. USER\_ID and initial PASSWORD will be communicated to the bidder through e-mail at the e-mail address provided along with request for bid documents as mentioned in 2.2(i) above and will be allowed to participate in the bidding through OIL's E-Procurement portal.
- 2.3 a) Bidders without having E-tender Login ID and Password should complete their online registration at least seven (7) days prior to the scheduled bid closing date and time of the tender. For online registration, Bidder may visit the OIL's E-tender site <https://etender.srm.oilindia.in/irj/portal>
- b) Necessary Login ID & Password will be issued by OIL only after submitting the complete online registration by the Bidder. In the event of late registration/incomplete registration by Bidder, OIL INDIA LIMITED shall not be responsible for late allotment of User ID & Password and request for bid closing date extension on that plea shall not be entertained by Company.
- c) **EMD/Bid security is not applicable against this tender and may be paid in the form of Demand Draft/Banker Cheque /Bank Guarantee (as per Proforma-D) . DECLARATION FOR BID SECURITY(if applicable) is to be furnished by the bidders along with the technical RFX in case of seeking exemption from submission of Bid security/ EMD) ,as per Proforma-R.**
- d) **For availing benefits under Public Procurement Policy (Purchase preference), the interested MSE Bidders must ensure that they are the manufacturer/ service provider of tendered item(s) and registered with the appropriate authority for the said item(s). If the technical offer does not include a valid copy of relevant MSE Certificate issued by appropriate authority specifying the item as per tender will be summarily rejected.** Late communication in this regard and request for bid closing date extension on that plea shall not be entertained by Company.
- e) **Financing of trade receivables of Micro and Small Enterprises (MSEs) through Trade Receivables Discounting System (TReDS) platform.**

Financing of trade receivables of Micro and Small Enterprises (MSEs) through Trade Receivables Discounting System (TReDS) platform.

Based on the initiatives of Government of India to help MSE vendors get immediate access to liquid fund based on Buyers credit rating by discounting, OIL has registered itself on TReDS platform with M/s RXIL and M/s A TREDS Ltd. (Invoice Mart). MSE vendors can avail this benefit by registering themselves with any of the exchanges providing e-discounting / electronic factoring services on TReDS platform and following the procedures defined therein, provided OIL is also participating in such TReDS Platform as a Buyer.

- (i) MSE Vendor should be aware that all costs relating to availing the facility of discounting on TReDS platform including but not limited to Registration charges, Transaction charges for financing, Discounting Charges, Interest on financing, or any other charges known by any name shall be borne by MSE Vendor.
- (ii) MSE Vendor hereby agrees to indemnify, hold harmless and keep OIL and its affiliates, Directors, officers, representatives, agents and employees indemnified, from any and all damages, losses, claims and liabilities (including legal costs) which may arise from Sellers submission, posting or display, participation, in any manner, on the TReDS Platform or from the use of Services or from the Buyer's breach of any of the terms and conditions of the Usage Terms or of this Agreement and any Applicable Law on a full indemnity basis.
- (iii) OIL shall not be liable for any special, indirect, punitive, incidental, or consequential damages or any damages whatsoever (including but not limited to damages for loss of profits or savings, business interruption, loss of information), whether in contract, tort, equity or otherwise or any other damages resulting from using TReDS platform for discounting their (MSE Vendor's) invoices.

Note:

- (i) Buyer means OIL who has placed Purchase Order/ Contract on a MSE Vendor (Seller).
- (ii) Seller means a MSE vendor, who has been awarded Purchase Order/ Contract by OIL (Buyer).

3.0 **EXEMPTION FROM SUBMISSION OF BID SECURITY/EMD(if applicable):** In case any bidder is exempted from paying the Bid security, they should upload the supporting documents along with their technical bid. The detailed guidelines for exemption of the Bid security are given below:

- a) **MSEs Units (manufacturers / Service Providers only and not their dealers / distributors) are eligible for exemption of Bid Security.**
- b) **Central/ State Govt. department / Public Sector Undertaking are also exempted from submission of bid security.**

Note: ***Bids without EMD shall be rejected, if the technical offer does not include a valid copy of relevant Document/Certificate towards exemption of EMD, issued by appropriate authority.***

- c) Documentation required to be submitted by MSE BIDDERS :

Categorization and various criteria applicable to MSE bidders shall be guided by the Gazette Notification No. CG-DL-E-26062020-220191 dated 26.06.2020.



**OIL INDIA LIMITED**  
**(A Government of India Enterprise)**  
**CONTRACTS DEPARTMENT, PHQ**  
**P.O. Udayan Vihar – 781171, Guwahati, ASSAM**

OIL INDIA LIMITED invites ON-LINE BIDS from eligible Bidders/Firms for the following mentioned works/services under **SINGLE STAGE SINGLE BID SYSTEM** through its e-Procurement site .

**DESCRIPTION OF WORK/ SERVICE:**

**Maintenance of OFC cable and other Telecom activities for a period of two years extendable by another one year upon review under PS5 Sector(ROW Chainage PLKM 352-497 & Spur Line PHQ - GHY Refinery Termianl)**

<b>IFB NO:</b>	<b>CGI7847P25</b>
<b>Type of IFB:</b>	<b>Single Stage Single Bid System(Composite)</b>
<b>Location:</b>	<b>PS5 TELECOM ROW Chainage PLKM 352-497 &amp; Spur Line PHQ - GHY Refinery Termianl)</b>
<b>Contract Period:</b>	<b>2 (two)years extendable by 1(one) year</b>
<b>Mobilisation Period:</b>	<b>1(one) day</b>
<b>Pre-Bid meeting</b>	<b>Not Applicable</b>
<b>Technical Bid Closing/ Opening Date &amp; Time:</b>	As per online data
<b>Price Bid Opening Date &amp; Time:</b>	As per online data
<b>Bid Submission Mode:</b>	Bid should be submitted online in OIL's E-Procurement Portal
<b>Bid Form Submission:</b>	Bid Form <b>Proforma-B</b> to be submitted along with Technical Bid
<b>Bid Opening Place:</b>	Office of the <b>GM(C&amp;P)</b> , Oil India Limited, Guwahati- 781171, Assam
<b>Bid Validity:</b>	<b>90 days from actual bid closing /opening date</b>
<b>Bid Security/EMD Amount:</b>	<b>INR 1,31,700.00</b>
<b>Bid Security /EMD validity</b>	<b>120 days from actual bid closing /opening date</b>
<b>Amount Of Performance Security:</b>	<b>10% of contract value</b>
<b>Validity of Performance Security:</b>	<b>3 months beyond contract period.</b>

**Clauses a) is not applicable for this tender.**

- a) **Bid Security** deposited vide **Demand Draft/Banker Cheque /Bank Guarantee No.** \_\_\_\_\_ **dated** \_\_\_\_\_ **of** \_\_\_\_\_

Original hard copy of (a) ( In case of Bidders submitting Bid Security in the form of Bank Draft/Banker cheque/Bank Guarantee) should reach the office of **General Manager(C&P)** on or before **13:30 Hrs (IST) on the bid closing date** or it **can be paid through the online payment Gateway against this Tender, otherwise Bid will be rejected**. A scanned copy of Bid security/EMD invoice (In case of Bid security submitted online) should also be uploaded along with the Un-priced Techno-commercial bid documents.

**A Bank Guarantee in the prescribed format issued by any of the following Bank is only acceptable:**

**i) Any schedule Indian Bank or Any Branch of an International bank situated in India and registered with Reserve Bank of India as scheduled foreign bank in case of domestic bidder OR**

**ii) Any foreign Bank which is not a Scheduled Bank in India, provided the Bank Guarantee issued by such Bank is counter-guaranteed by any Branch situated in India of any Scheduled Bank incorporated in India.**

**Bank Guarantee issued by a scheduled Bank in India at the request of some other Non-Scheduled Bank of India shall not be acceptable.**

**The bank guarantee issued by the bank must be routed through SFMS platform as per the following details:**

- a) (i) **“MT760/ MT760 COV for issuance of bank guarantee”**  
(ii) **“MT767/ MT767 COV for issuance of bank guarantee”**

**The above message/ intimation shall be sent through SFMS by the BG issuing bank branch to Axis Bank, Guwahati Branch, IFS Code- UTIB0000140, Branch Address – Axis Bank Ltd, Guwahati Branch, Chibber House, G S Road, Dispur, Assam, PIN- 781005.”**

**b) The vendor shall submit to OIL the copy of SFMS message as sent by the issuing bank branch along with the original bank guarantee**

- b) Bidders to confirm that in the event of award of Contract, bidder will submit **Performance Security Deposit @ 10% of contract value** and this will not earn any interest.

**A Bank Guarantee in the prescribed format issued by any of the following Bank is only acceptable:**

i) Any schedule Indian Bank or Any Branch of an International bank situated in India and registered with Reserve Bank of India as scheduled foreign bank in case of domestic bidder OR

ii) Any foreign Bank which is not a Scheduled Bank in India, provided the Bank Guarantee issued by such Bank is counter-guaranteed by any Branch situated in India of any Scheduled Bank incorporated in India.

Bank Guarantee issued by a scheduled Bank in India at the request of some other Non-Scheduled Bank of India shall not be acceptable.

The bank guarantee issued by the bank must be routed through SFMS platform as per the following details:

- a) (i) “MT760/ MT760 COV for issuance of bank guarantee”  
(ii) “MT767/ MT767 COV for issuance of bank guarantee”

The above message/ intimation shall be sent through SFMS by the BG issuing bank branch to Axis Bank, Guwahati Branch, IFS Code- UTIB0000140, Branch Address – Axis Bank Ltd, Guwahati Branch, Chibber House, G S Road, Dispur, Assam, PIN- 781005.”

b) The vendor shall submit to OIL the copy of SFMS message as sent by the issuing bank branch along with the original bank guarantee

2.0 (a) SEALED ENVELOPES containing the **Bid Security, Printed catalogue and Literature, if called for in the tender** shall be marked with the above IFB Number and description of work and submitted in the office of:

GM(C&P)  
CONTRACTS DEPARTMENT, PHQ  
OIL INDIA LIMITED  
GUWAHATI- 781171, ASSAM.

All bidders should submit the **Bid Security (if applicable)/Declaration for Bid security(if applicable)** confirming that the Bid is valid for minimum **90 days** from actual bid closing /opening date. *Bid without submission of Bid security (if applicable) will be summarily rejected.*

Bids without **Bid Security(if applicable)/ DECLARATION FOR BID SECURITY (as per PROFORMA-R),if applicable**, in the manner specified above will be summarily rejected.

DECLARATION FOR BID SECURITY

.

To,

M/s. Oil India Limited

.....

.....

Sub: .....

Tender No:.....

Dear Madam/Sir,

After examining / reviewing provisions of above referred tender documents (including all corrigendum/ Addenda), we M/s. .... (Name of Bidder) have submitted our offer / bid no.....

We, M/s. ....(Name of Bidder) hereby understand that, according to your conditions, we are submitting this Declaration for Bid Security.

We understand that we will be put on watch list/holiday/banning list (as per policies of OIL INDIA in this regard), if we are in breach of our obligation(s) as per following:

- (a) have withdrawn/modified/amended, impairs or derogates from the tender, my/our Bid during the period of bid validity specified in the form of Bid; or
- (b) having been notified of the acceptance of our Bid by the OIL INDIA LIMITED during the period of bid validity:
  - (i) fail or refuse to execute the Contract, if required, or
  - (ii) fail or refuse to furnish the Contract Performance Security, in accordance provisions of tender document.
  - (iii) Fail or refuse to accept 'arithmetical corrections' as per provision of tender document.
- (c) having indulged in corrupt/fraudulent/collusive/coercive practice as per procedure.

Place:

[Signature of Authorized Signatory of Bidder]

Date:

Name:

Designation:

Seal:

- 3.0 **Bid should be submitted online up to 11:00 AM (IST) (OIL's e-procurement Portal Server Time) on the date as mentioned and will be opened on the same day at/after 02:00 PM (IST) at Office of the GM(Contracts) in presence of authorized representative of the bidder.**
- 4.0 **All the Bids must be Digitally Signed using "Class 3" digital certificate [Organization] (e-commerce application)** only as per Indian IT Act obtained from the licensed Certifying Authorities operating under the Root Certifying Authority of India (RCAI), Controller of Certifying Authorities (CCA) of India. The bid signed using other than "Class 3" digital certificate, will be liable for rejection. Please note Encryption certificate is also required along with Digital Certificate Class III [Organization] in order to submit bid in system. Please refer "Guideline to Bidder for participating in OIL"
- 5.0 The Company reserves the right to reject any or all the tenders or accept any tender without assigning any reason.
- 6.0 (a) No Bidder can withdraw his bid within the validity or extended validity of the bid. Withdrawal of any bid within validity period will be debarred from participation in future tenders, at the sole discretion of the company.
- (b) Once a withdrawal letter is received from any bidder, the offer will be treated as withdrawn and no further claim / correspondence will be entertained in this regard.
- 7.0 Conditional bids are liable to be rejected at the discretion of the Company.
- 8.0 The bidders are required to furnish the composition and status of ownership of the firm in whose name bid documents have been purchased/issued along with one or more of the following documentary evidences (which are applicable to the bidder) in support of the same and scanned copies of the same should be uploaded along with the Un-priced bid documents.
- 8.1 In case of Sole Proprietorship Firm, Copies of Telephone(Landline Bill)/Electricity/PAN card, latest Income Tax Return form indicating therein the name, business and residential address, E-mail and telephone numbers of the owner and copies of GST and Central Excise Registration Certificate.
- 8.2 In case of HUF, Copies of Telephone(Landline Bill)/Electricity/PAN card, latest Income Tax Return form, Family Arrangement indicating therein the name, residential address, E-mail and telephone numbers of the owners in general and Karta in particular and copies of GST and Central Excise Registration Certificate.
- 8.3 In case of Partnership Firm, Copies of Telephone (Landline Bill)/Electricity/PAN card, latest Income Tax Return form indicating therein the name,

residential address, E-mail and telephone numbers of all the partners (including the Managing Partner), registered partnership agreement/deed and copies of GST Registration Certificate.

- 8.4 In case of Co-Operative Societies, Copies of Telephone(Landline Bill)/Electricity/PAN card, latest Income Tax Return form indicating therein the name, residential address, E-mail and telephone numbers of all the Directors or persons who are at the helm of affairs, registration certificate from Registrar of Co-Operative Societies and copies of GST Registration Certificate.
- 8.5 In case of Societies registered under the Societies Registration Act, Copies of Telephone (Landline Bill)/Electricity/PAN card, latest Income Tax Return form indicating therein the name, residential address, E-mail and telephone numbers of all the Directors or persons who are at the helm of affairs, registration certificate from the Registrar of the state and copies of GST Registration Certificate.
- 8.6 In case of Joint Stock Companies registered under the Indian Companies Act, Copies of Telephone (Landline Bill)/Electricity/PAN card, latest Income Tax Return form indicating therein the name, residential address, E-mail and telephone numbers of all the Directors or persons who are at the helm of affairs, Certificate of Incorporation from the Registrar of Companies, Memorandum and Articles and copies of GST Registration Certificate.
- 8.7 In case of Trusts registered under the Indian Trust Act, Copies of Telephone (Landline Bill)/Electricity/ PAN card, latest Income Tax Return form indicating therein the name, residential address, E-mail and telephone numbers of all the Trustee or persons who are at the helm of affairs, registration certificate from the Registrar of the state, Trust Deed and copies GST Registration Certificate.
- 9.0 The selected bidder will be required to enter into a formal contract, which will be based on their bid and O.I.L's Standard Form of Contract.
- 10.0 Time will be regarded as the essence of the Contract and the failure on the part of the Contractor to complete the work within the stipulated time shall entitle the Company to recover liquidate damages and / or penalty from the Contractor as per terms of the tender /contract.
- 11.0 The contractor will be required to allow OIL officials to inspect the work site and documents in respect of the workers payment.
- 12.0 **The successful bidder shall furnish a Performance Security Deposit in the form of Demand Draft / Banker's Cheque / Bank Guarantee as specified above within 30 days ~~2(two) weeks~~ from date of issue of LOA**

**before signing the formal contract.** The Performance Security Deposit will be refunded to the Contractor after satisfactory completion of the work, but a part or whole of which shall be used by the Company in realization of liquidated damages or claims, if any or for adjustment of compensation or loss due to the Company for any reason. This Performance Security Money shall not earn any interest.

- 13.0 **BACKING OUT BY BIDDER:** In case any bidder withdraws their bid within the bid validity period, the party will be debarred for a period of 2(two) years from the date of withdrawal of bid.
- 14.0 **BACKING OUT BY L-1 BIDDER AFTER ISSUE OF LOA:** In case LOA issued is not accepted by the L1 bidder **the bidder shall be debarred for 2 (two) years from the date of default.**
- 15.0 **FURNISHING FRAUDULENT INFORMATION/DOCUMENT:** Bidder should note that the documents/information submitted by the bidders(s) against the tender are presumed to be genuine, authentic and true copy of the originals. In case at any stage of tendering process or during execution of contract or after expiry of contract, if it is found at any time that, a Bidder / Contractor has / had furnished fraudulent documents / information, the company shall immediately reject the bid of such bidder(s) or cancel /terminate the contract, as the case may be . Also the bidder / the party/the contractor shall be debarred for a period of two (02) years from the date of issuance of debarment notice, besides legal action.
- 16.0 **The tender will be governed by:**  
**Forwarding Letter.**  
Instruction to Bidders-**Part-1**  
BRC-BEC-Bid Rejection Criteria & Bid Evaluation Criteria –**Part-2**  
General Conditions of Contract. (GCC) **Part –3, Section-I**  
Terms of Reference, **Part-3, Section-II**  
Special Conditions of Contract (SCC), **Part-7, Section-III**  
Schedule of Work, Unit and Quantity (SOQ)- **Part-4, Section-II**  
**Proforma and Annexures**
- 17.0 The **Integrity Pact** is **APPLICABLE** against this tender:

OIL shall be entering into an Integrity Pact with the bidders as per format enclosed vide **“Proforma -I”** of the tender document. This Integrity Pact Proforma has been duly signed digitally by OIL’s competent signatory (Digitally Signed). The proforma has to be returned by the bidder (along with the technical bid) duly signed (digitally) by the same signatory who signed the bid, i.e., who is duly authorized to sign the bid. Uploading the Integrity Pact with digital signature will be construed that all pages of the Integrity Pact has been signed by the bidder’s authorized signatory who sign the Bid.

(Note: Following person has been appointed as Independent External Monitor:

A. Shri Ram Phal Pawar, IPS (Retd.), Former Director, NCRB, MHA,  
E-mail IDs: rpawar61@hotmail.com , ramphal.pawar@ips.gov.in

B. Dr. Tejendra Mohan Bhasin,  
Former Vigilance Commissioner, CVC  
E-mail: tmbhasin@gmail.com

C. Shri Ajit Mohan Sharan, IAS (Retd.)  
Former Secretary,  
Ministry of Ayush,  
Govt. of India  
E-mail: ams057@gmail.com

18.0 **SPECIAL NOTE:**

**GUIDELINES FOR PARTICIPATING IN OIL'S E-PROCUREMENT:**

To participate in OIL's E-procurement tender, bidders should have a legally valid digital certificate of Class 3 with Organizations Name as per Indian IT Act from the licensed Certifying Authorities operating under the Root Certifying Authority of India (RCAI), Controller of Certifying Authorities (CCA) of India (<http://www.cca.gov.in>). Bidders must have a valid User Id to access OIL e-Procurement site. Bidders can click on Guest login button to view the available open tenders in the E-portal. Bidders shall request OIL through E-mail or fax or letter along with the cost of bid documents as indicated in the NIT for issue of the USER ID for accessing and submitting against the E-procurement tender. The User ID shall be issued to the eligible bidders on receipt of the requisite cost of the bid document. In case any bidder is exempted from paying the tender fee, they should request OIL with supporting documents for issue of the User Id on free of charge basis. The detailed guidelines are available in OIL's e-procurement site. For any clarification in this regard, bidders may contact OIL.

Please note that all tender forms (Bid document, Integrity Pact, Proforma, Annexure) and supporting documents are to be submitted through OIL's E-Procurement site only **except Original Bid Security(if applicable)** and any other document if specified in the IFB which are to be submitted in sealed envelope super scribed with tender no. and due date to: The **G.M. (Contracts), Pipeline Head Quarter, Oil India Limited, Guwahati-781171, ASSAM**

Bidders are requested to examine all instructions, forms, terms and specifications in the bid. Failure to furnish all information required as per the bid or submission of offers not substantially responsive to the bid in every respect will be at the bidders risk and may result in the rejection of its offer

without seeking any clarifications. Offers sent without the requisite value of prescribed bid security (if called for in the bid) in original will be ignored straightway.

Please note Encryption certificate is also required along with Digital Certificate Class III [Organization in order to submit bid in system. Please refer “Guideline to Bidder for participating in OIL”

19.0 The tender is invited under **SINGLE STAGE SINGLE BID SYSTEM**. The bidder has to submit the “Un-Priced Techno-Commercial” and “Price-Bid” through electronic form in the OIL’s e-Tender portal within the Bid Closing Date and Time stipulated in the e-Tender portal. **The Technical Bid is to be submitted as per Scope of Work & Technical Specifications along with all technical related documents related to the tender are to be uploaded under Technical RFx Tab.** The Price Bid rates shall be quoted as specified in the “PRICE BID FORMAT” and to be attached as attachment under the Notes & attachment tab. **The price quoted in the “PRICE BID FORMAT” will only be considered for evaluation.**

**Please note that no price details should be uploaded under Technical RFx. Details of prices as per Price Bid format / Priced bid can be uploaded as Attachment under Notes & Attachment Tab. Offer not complying with above submission procedure will be rejected.**

A few screen shots to find out the required IFB is shown below.

Notes and Attachments	→ Only Price Details Should Be Uploaded
Technical attachments	→ All technical bid documents except price details

Please do refer “**NEW INSTRUCTION TO BIDDER FOR SUBMISSION**” for the above two points and also please refer “**New Vendor Manual (effective 12.0.2017)**” available in the login Page of the OIL’s E-tender Portal.

Regarding new bid submission procedure (effective from 12.04.2017 onwards), please refer **new vendor manual** available in OIL's E-tender Site:

**Notes :**

- \* The “Techno-Commercial Unpriced Bid” shall contain all techno-commercial details except the prices.
- \*\* The “Price bid” must contain the price schedule and the bidder’s commercial terms and conditions. For uploading Price Bid, first click on Sign Attachment, a browser window will open, select the file from the PC and click on Sign to sign the Sign. On Signing a new file with extension .SIG will be created. Close that window. Next click on Add Attachment, a browser window will open, select the .SIG signed file from the PC and name the file under Description, Assigned to General Data and click on OK to save the File.
- 8.0 Bidder is responsible for ensuring the validity of digital signature and its proper usage by their employee.
- 9.0 The bid including all uploaded documents shall be digitally signed by duly authorized representative of the bidding company.
- 10.0 OIL reserves the right to increase/decrease the quantum of job at the time of award of contract and it will be obligatory on the part of the successful bidder to accept the same at the offered rates.
- 11.0 The Company reserves the right to reject any or all the tenders or accept any tender without assigning any reason.
- 12.0 Offer must conform in all respect to the terms and conditions of the enquiry. Deviations, if any, must be clearly and specifically stated. Conditional bids are liable to be rejected at the discretion of the Company.



**E-TENDER: CGI7847P25**  
**PART-1**  
**INSTRUCTIONS TO BIDDERS (ITB)**

**1.0 Eligibility of the bidder:**

- 1.1 The eligibility of the bidder are listed under **BID EVALUATION CRITERIA (BEC), PART-2** of the Bid document.
- 1.2 Bidder shall bear all costs associated with the preparation and submission of bid. Oil India Limited, hereinafter referred to as Company, will in no case be responsible or liable for those costs, regardless of the conduct or outcome of the bidding process.

**2.0 Bid Documents:**

- 2.1 The services required, bidding procedures and contract terms are prescribed in the Bid Document. This Bid Document includes the following:
- a) A Tender Forwarding Letter
  - b) Instructions to Bidders, (Part-1)
  - c) Bid Evaluation/Rejection Criteria (Part-2)
  - d) General Conditions of Contract, (Part-3) Section-I
  - e) Schedule of Quantities/Rates, SOQ/SOR (Part-4)
    - f) Scope of Work/Terms of Reference/Schedule of company's Plants, Materials and Equipments (SCPME) (Part-5)
  - g) Payment Terms (Part-6)
  - h) Special Conditions of Contract (Part 7) Section-III
  - i) Price Schedule Format, (Proforma-A)
  - j) Bid Form, (Proforma-B)
  - k) Statement of Non-Compliance, (Proforma-C)
  - l) Bid Security ~~declaration~~—BG Format (Proforma-D)**if applicable**
  - m) Performance Security Form, (Proforma-E)
  - n) Sample Agreement Form (Proforma-F)
  - o) Proforma of Letter of Authority (Proforma-G)
  - p) Authorization for Attending Bid Opening (Proforma-H)
  - q) Integrity Pact (Proforma -I) **(if applicable)**
  - r) Safety Measures (Proforma – J)
  - s) UNDERTAKING TOWARDS PURCHASE PREFERENCE(Proforma -K)**if applicable**
  - t) UNDERTAKING FOR LOCAL CONTENT (Proforma -K1)**if applicable**
  - u) Proforma of Bank Guarantee towards PP-LC (Proforma -K2) **if applicable**
  - v) Certificate of Compliance of Financial Criteria (Proforma –L)**if applicable**
  - w) Format of undertaking by Bidders towards submission of authentic information/documents (Proforma –M)
  - x) E-remittance format (Proforma –N)
  - y) Format for undertaking -(Proforma –O)
  - z) E–Payments vide RTGS/NEFT-(Proforma –P)
  - aa) Proforma of indemnity bond for supply of materials by purchaser/ owner-(Proforma –Q)
  - bb) DECLARATION FOR BID SECURITY (Proforma –R),**if applicable**

## **E-TENDER: CGI7847P25**

2.2 The bidder is expected to examine all instructions, forms, terms and specifications in the Bid Documents. Failure to furnish all information required in the Bid Documents or submission of a bid not substantially responsive to the Bid Documents in every respect will be at the Bidder's risk & responsibility and may result in the rejection of its bid.

2.3 Bidders shall be deemed, prior to submitting their bids, to have satisfied themselves about the weather conditions, working culture in the area, socio-political environment, safety & security aspects, law & order situation and law of the land, and obtain for themselves all necessary information as to the risks, contingencies and all other circumstances, which may influence or affect the various obligations under the Contract.

### **3.0 Transferability of bid documents:**

3.1 Bid Documents are non-transferable. Bid can be submitted only by the bidder in whose name the Bid Document has been issued/registered.

3.2 **In case of e-Tender, Bidder must submit the bid using Organizational Class-3 Digital Signature issued by the Competent Authority in favour of the bidder. Bid submitted using Digital Signature other than the Digital Signature of the bidder shall be summarily rejected.**

3.3 Unsolicited bids will not be considered and will be rejected straightway.

### **4.0 Amendment of bid documents:**

4.1 At any time prior to the deadline for submission of bids, the Company may, for any reason, whether at its own initiative or in response to a clarification requested by a prospective Bidder, modify the Bid Documents through issuance of an Addendum(s)/Corrigendum(s)/Amendment(s).

4.2 The Addendum will be uploaded in OIL's E-Tender Portal in the Tab "Technical Rfx" and under External Area - "Amendments" folder. The Company may, at its discretion, extend the deadline for bid submission. Bidders are expected to take the Addendum into account in preparation and submission of their bid. Bidders are to check from time to time the E-Tender portal ["Technical RFX" Tab and under the folder "Amendments"] for any amendments to the bid documents before submission of their bids. No separate intimation shall be sent to the Bidders.

### **5.0 Preparation of Bids**

5.1 Language of Bids:

## **E-TENDER: CGI7847P25**

5.1.1 The bid prepared by the bidder and all correspondence and documents relating to the bid exchanged by the Bidder and the OIL shall be written in English language. Supporting documents and printed literature furnished by the Bidder may be in another language provided they are accompanied by an accurate translation of the relevant passages in English, duly authenticated by local chamber of Commerce of bidder's country, in which case, for purposes of interpretation of the bid, the translation shall prevail.

5.2 Bidder's/Agent's Name & address:

5.2.1 Bidders should indicate in their bids their detailed postal address including the Fax/Telephone / Cell Phone Nos. and E-mail address. Similar information should also be provided in respect of their authorised Agents in India, if any.

### 5.3 **Documents comprising the bid:**

5.3.1 Bids are invited under **Single Stage Single Bid System**. The bid to be uploaded by the Bidder in OIL's E-Tender portal shall comprise of the following components:

- (A) Technical Bid (to be uploaded in "Technical Attachments" tab)
- a) Complete technical details of the services offered.
  - b) Documentary evidence established in accordance with **Clause 9.0**.
  - c) **Bid Security(if applicable) / DECLARATION FOR BID SECURITY(if applicable)** is to be furnished by the bidders along with the technical RFX. In case of seeking exemption from submission of Bid security/ EMD(if applicable) **DECLARATION FOR BID SECURITY(if applicable)** is to to be submitted by bidders as per **Proforma-R**.
  - d) Copy of Bid-Form without indicating prices in **Proforma-B**.
  - e) Statement of Non-compliance as per **Proforma-C**.
  - f) ~~Proforma A: List of items to be imported without the CIF values (For Global Tenders).~~
  - g) ~~Copy of Priced Bid without indicating prices (Proforma B).~~
  - h) Integrity Pact (**if applicable**) digitally signed by OIL's competent personnel as **Proforma-I**. ~~Annexure V attached with the bid document to be digitally signed by the bidders Authorised representative.~~
  - i) All Other relevant Undertakings and Proformas as applicable as part of Bid.

**Note: Please note that, No price should be mentioned in the "Technical Attachments" tab.**

(B) **Price Bid (to be uploaded in "Notes and Attachments" tab)**

## E-TENDER: CGI7847P25

Bidder shall quote their prices in the following Proforma available in OIL's E-procurement portal in the "Notes & Attachments" Tab:

- a) Price-Bid Format as per **Proforma-A**
- b) Bid Form as per **Proforma-B**
- c) ~~Proforma A showing the items to be imported with the CIF values (For Global Tenders).~~

The Priced Bid shall contain the prices along with the currency quoted and any other commercial information pertaining to the service offered.

### **6.0 Bid Form:**

- 6.1 The bidder shall complete the Bid Form and the appropriate Price Schedule furnished in their Bid.

### **7.0 Bid Price:**

- 7.1 Prices must be quoted by the Bidders online as per the price bid format available in OIL's E-Tender Portal under "Notes & Attachment" Tab. Prices must be quoted by the bidders as per the Price/Bidding format.

- 7.2 **Prices quoted by the successful bidder must remain firm during its performance of the Contract and is not subject to variation on any account.**

- 7.3 All duties (except customs duty which will be borne by the Company) and taxes (excluding GST) including Corporate Income Tax, Personal Tax, Assam Entry Tax etc. and other Cess/levies payable by the successful bidder under the Contract for which this Bid Document is being issued, shall be included in the rates, prices and total Bid Price submitted by the bidder, and the evaluation and comparison of bids shall be made considering the quoted GST in the proforma. For example, personal taxes and/or any corporate taxes arising out of the profits on the contract as per rules of the country shall be borne by the bidder.

### **8.0 Currencies of bid and payment:**

- 8.1 A bidder expecting to incur its expenditures in the performance of the Contract in more than one currency, and wishing to be paid accordingly, shall so indicate in the bid. In such a case, the bid shall be expressed in different currencies and the respective amounts in each currency shall together make up the total price.

**E-TENDER: CGI7847P25**

8.2 Indian bidders too can submit their bids in any currency (including Indian Rupees) and receive payment in such currencies on par with foreign bidders. However, currency once quoted will not be allowed to be changed.

**9.0 Documents establishing bidder's eligibility and qualifications:**

9.1 These are listed in BID EVALUATION CRITERIA (BEC), **PART-2** of the Bid document.

**10.0 BID SECURITY : ( APPLICABLE FOR THIS TENDER)**

1. The Bid Security is required to protect the Company against the risk of Bidder's conduct, which would warrant forfeiture of the Bid Security, pursuant to sub-clause 8.
2. All the bids must be accompanied by Bid Security in Original as prescribed under, for the amount as mentioned in the "Forwarding Letter" of the tender documents:
  - a. The Bid Security may be submitted in the form of irrevocable Bank Guarantee (as per PROFORMA-D) issued by Nationalized or Scheduled Bank in favour of M/s Oil India Limited and payable at GUWAHATI. The Bank Guarantee must be on Non-Judicial Stamp Paper of requisite value as per Indian Stamp Act purchased in the name of Banker.
  - b. Alternately Bid Security can also be paid through Bank Draft/Cashier's Cheque/ Banker's Cheque/Fixed Deposit Receipt (Account OIL INDIA LIMITED)/irrevocable Letter of Credit/NEFT/RTGS/Electronic Fund Transfer through Online Payment Gateway of OIL's e-tender portal (subject to credit in OIL's account within prescribed time) to designated account of OIL.
    - i. If the Bid Security is submitted in the form of Bank Draft, Banker's Cheque, Cashier's Cheque, Fixed Deposit Receipt or Letter of Credit, the same should be in favour of "**Oil India Limited**" payable at **Guwahati**.
    - ii. Bid Security amount through NEFT or RTGS mode may be deposited on or before bid closing date and time to the following designated OIL's bank account:

**Note: Bank details of Oil India Limited may be required by Bank for issuance of Bank Guarantee (BG):**

<b>BANK DETAILS OF BENEFICIARY</b>		
<b>a</b>	Bank Name	AXIS BANK

**E-TENDER: CGI7847P25**

<b>b</b>	Branch Name	GUWAHATI
<b>c</b>	Branch Address	CHIMBER HOUSE, G.S.ROAD, DISPUR ASSAM
<b>d</b>	Banker Account No.	140010200027654
<b>e</b>	Type of Account	CURRENT ACCOUNT
<b>f</b>	IFSC Code	UTIB0000140
<b>g</b>	MICR Code	781211002
<b>h</b>	SWIFT Code	Axisinbb140
<b>i</b>	Contact No.	8876501401
<b>j</b>	Contact Person Name	Mr. Dibakar Ghaosh
<b>k</b>	Fax No.	Not available
<b>l</b>	Email Id	<a href="mailto:Guwahati.branchhead@axisbank.com">Guwahati.branchhead@axisbank.com</a>

- iii. If the bid security is submitted through NEFT or RTGS mode, details such as UTR No., Tender No., Bidder's name & Deposited Amount etc. must be uploaded with the Unpriced Techno-Commercial Bid documents.
- c. In case of Bidders submitting Bid Security in the form of Bank Guarantee/ Bank Draft/Cashier's Cheque/Banker's Cheque/Fixed Deposit Receipt/Letter of Credit, the original hard copy of Bid Security should reach the office of GM-CONTRACTS, OIL PHQ GUWAHATI-781171 on or before 12.45 p.m. (IST) on the bid closing / opening date otherwise bid will be rejected.
- d. Submission of Bid Security/Performance Security, as applicable, in the form of Electronic Bank Guarantee(e-BG) is also acceptable.

SL.NO.	BANK NAME	SL.NO.	BANK NAME
1	AU Small Finance Bank	12	IDFC First Bank
2	Axis Bank	13	Indian Bank
3	Bank of Baroda	14	Indian Overseas Bank
4	Bank of India	15	IndusInd Bank
5	Canara Bank	16	Karur Vysya Bank
6	City Union Bank	17	Kotak Mahindra Bank
7	Federal Bank	18	Punjab National Bank
8	HDFC Bank	19	RBI Bank
9	HSBC Bank	20	State Bank of India
10	ICICI Bank	21	South Indian Bank
11	IDBI Bank	22	Yes Bank

**E-TENDER: CGI7847P25**

Beneficiary details for issue of e-BG are:

Sl. No.	Particulars	Details
1	<b>Name</b>	<b>Oil India Limited</b>
2	<b>PAN</b>	<b>AAACO2352C</b>
3	<b>Date of Incorporation</b>	<b>18.02.1959</b>
4	<b>Email ID</b>	<a href="mailto:bikram_chakraborty@oilindia.in">bikram_chakraborty@oilindia.in</a> <a href="mailto:prasoon_tripathi@oilindia.in">prasoon_tripathi@oilindia.in</a>
5	<b>Mobile No.</b>	<b>9954067677/967222247</b>
6	<b>Local Address</b>	<b>Oil India Limited, PHQ, Narangi</b>

- e. A scanned copy of Bid Security document should also be uploaded along with the Unpriced Techno-Commercial Bid documents.
- f. This Bid Security Deposit shall be refunded to all unsuccessful bidders but is liable to be forfeited in full or part, at Company's discretion, as per Clause No. 8 below. Bids without Bid Security Deposit in the manner specified above will be summarily rejected.
- g. No other mode of payment will be accepted by the Company. The Bid Security shall not earn any interest to the bidder from the Company.

Note:

i. Bidders claiming waiver of Bid Security shall upload supporting documents as mentioned in Para No. 2.3 below along with technical bid.

**ii. Any offer not accompanied with the Bid Security shall be treated as invalid and summarily rejected unless the bidder is exempted from submission of Bid Security as per Bid Security Exemption Criteria of this tender and proper proof towards this exemption is submitted by the bidder. Any subsequent deposit of Bid Security after the bid closing date shall not be permitted. Also, adjustment of Bid Security due against the instant tender, against dues from the Company or on any account shall not be permitted.**

3. Any bid not secured in accordance with sub-clause 2 above shall be rejected by the Company as non-responsive.

4. The bidders shall extend the validity of the Bid Security suitably, if and when specifically advised by OIL, at the bidder's cost.

5. Unsuccessful Bidder's Bid Security will be discharged and / or returned within 30 days after finalization of the Tender.

6. Successful Bidder's Bid Security will be discharged and / or returned upon Bidder's furnishing the Performance Security and signing of the contract. Successful bidder will however ensure validity of the Bid Security

**E-TENDER: CGI7847P25**

till such time the Performance Security in conformity with Clause No. 31.0 below is furnished.

7. Bid Security shall not accrue any interest during its period of validity or extended validity.

**11.0 Exemption from submission of bid security: (if applicable)**

**11.1 Central/ State Govt. department / Public Sector Undertaking are exempted from submission of bid security .**

**11.2 Micro or Small Enterprises (MSE) bidders are exempted from submitting Bid Security.** Categorization and various Criteria applicable to MSE bidders shall be guided by the Gazette Notification No. CG-DL-E-26062020-220191 dated 26.06.2020 issued by MINISTRY OF MICRO, SMALL AND MEDIUM ENTERPRISES. ~~The existing enterprises registered under EM Part II or UAM till 30th June'2020 shall continue to be valid only for a period up to the 31st day of March, 2021.~~

11. 3 The bidder claiming as MSE status (MSE-General, MSE-SC/ST, MSE -Woman) against this tender has to submit the following documents for availing the benefits applicable to MSEs:

**i. Udyam Registration Number ( URN) with Udyam Registration Certificate(URC)**

**11.3.1** In case bidding MSE is owned by Schedule Caste or Schedule Tribe entrepreneur or Woman Entrepreneur, valid documentary evidence issued by the agency who has registered the bidder as MSE owned by SC/ST entrepreneur/ Woman Entrepreneurs should also be enclosed.

**12.0 PERIOD OF VALIDITY OF BIDS :**

12.1 Bids shall remain valid as per the requirement mentioned in forwarding letter from the date of closing of bid prescribed by the Company. **Bids of shorter validity will be rejected as being non-responsive.** If nothing is mentioned by the bidder in their bid about the bid validity, it will be presumed that the bid is valid for **90 days** from **actual bid closing /opening date.**

12.2 In exceptional circumstances, the Company may solicit the Bidder's consent to an extension of the period of validity. The request and the response thereto shall be made in writing through Fax or e-mail. A Bidder granting the request will neither be required nor permitted to modify their Bid.

**13.0 Signing & submission of bids:**

**13.1 Signing of bids:**

**E-TENDER: CGI7847P25**

13.1.1 Bids are to be submitted online through OIL's E-procurement portal with digital signature. The bid and all attached documents should be digitally signed by the bidder using "Class 3" digital certificates with Organization's Name [e-commerce application (Certificate with personal verification and Organization Name)] as per Indian IT Act 2000 obtained from the licensed Certifying Authorities operating under the Root Certifying Authority of India (RCAI), Controller of Certifying Authorities (CCA) of India before bid is uploaded. Digital Signature Certificates having Bidder's Name in the "Organization Name" field are only acceptable. Digital Signature Certificate having "Organization Name" field other than Bidder's Name shall be rejected summarily.

The bid including all uploaded documents shall be digitally signed by duly authorized representative of the bidder holding a Power of Attorney to bind the Bidder to the contract.

If any modifications are made to a document after attaching digital signature, the digital signature shall again be attached to such documents before uploading the same. The Power of Attorney in original shall be submitted by bidder as mentioned in Para 13.2 below.

In case the digital signature is not of "Class-3" with organization name, the bid will be rejected. Bidder is responsible for ensuring the validity of digital signature and its proper usage by their employees.

13.1.2 The original and all copies of the bid shall be typed or written in indelible inks. Since bids are to be submitted ONLINE with digital signature, manual signature is NOT relevant. The letter of authorization (as per Proforma-H) shall be indicated by written Power of Attorney accompanying the Bid.

13.1.3 Any physical documents submitted by bidders shall contain no interlineations, white fluid erasures or overwriting except as necessary to correct errors made by the Bidder, in which case such correction shall be initialed by the person or persons who has/have digitally signed the Bid.

13.1.4 Any Bid, which is incomplete, ambiguous, or not in compliance with the Bidding process shall be rejected.

13.2 **Submission of bids:**

The tender is processed under **Single Stage Single bid system**. Bidder shall submit the Technical bid and Priced bid along with all the Annexures and Proforma (wherever applicable) and copies of documents in electronic form through OIL's e-procurement portal within the Bid Closing Date & Time stipulated in the e-tender. For submission of Bids online at OIL's E-Tender

## **E-TENDER: CGI7847P25**

Portal, detailed instructions is available in “User Manual” available in OIL’s E-Tender Portal. Guidelines for bid submission are also provided in the “Forwarding Letter”. The Technical Bid is to be submitted as per Terms of Reference/Technical Specifications of the bid document and Priced Bid as per the Price Schedule. The Technical Bid should be uploaded in the “Technical Attachment” Tab Page only. Prices to be quoted as per **Proforma-A** should be uploaded as Attachment just in the attachment link under “Notes & Attachments” Tab under General Data in the e-portal. No price should be given in the “Technical Attachment”, otherwise bid shall be rejected. The priced bid should not be submitted in physical form and which shall not be considered. However, the following documents in one set should necessarily be submitted in physical form in sealed envelope superscribing the “IFB No., Brief Description of services and Bid Closing/Opening date & Time along with the bidder’s name and should be submitted to GM-Contracts, Oil India Ltd., Guwahati-781171 (Assam) on or before 12.45 Hrs (IST) on the bid closing date indicated in the IFB:

- a) The Original Bid Security **(if applicable)** along with 1(one) copy
- b) Printed catalogue and literature if called for in the bid document.
- c) Power of Attorney for signing of the bid digitally.
- d) Any other document required to be submitted in original as per bid document requirement.

Documents sent through E-mail/Fax/Telephonic method will not be considered.

13.2.1 All the conditions of the contract to be made with the successful bidder are given in various Sections of the Bid Document. Bidders are requested to state their non-compliance to each clause as per Proforma-C of the bid document and the same should be uploaded along with the Technical Bid.

13.2.2 Timely delivery of the documents in physical form as stated in Para 13.2 above is the responsibility of the bidder. Bidders should send the same through Registered Post or by Courier Services or by hand delivery to the Officer in Charge of the particular tender before the Bid Closing Date and Time. Company shall not be responsible for any postal delay/transit loss.

13.2.3 Bids received through the e-procurement portal shall only be accepted. Bids received in any other form shall not be accepted.

**14.0** Indian agent/representative/retainer/associate Foreign bidders shall clearly indicate in their bids whether they have an Agent/Representative/Retainer/Associate in India. In the event the overseas bidder is having an Agent/Representative/Retainer/Associate in India, the bidder should furnish the name and address of their Agent/Representative/Retainer/Associate in India and clearly indicate nature and extent of services to be provided by such an Agent/

## **E-TENDER: CGI7847P25**

Representative/Retainer/Associate in India and also stating in their bids whether the Agent/Representative/Retainer/Associate is authorized to receive any commission. The rate of the commission included in the quoted rates of bidder should be indicated which would be payable to Agent/Representative/Retainer/Associate in non-convertible Indian currency according to Import Trade Regulation of India. Unless otherwise specified, it will be assumed that agency commission is not involved in the particular bid.

Further, overseas bidders shall submit their bids directly and not through their Agent/Representative/Retainer/Associate in India. Bid submitted by Indian Agent/Representative/Retainer/Associate on behalf of their foreign principals will not be considered and will be rejected straightway. Moreover, one Indian Agent/Representative/Retainer/Associate cannot represent more than one foreign bidder against the IFB.

The Indian Agent/Representative/Retainer/Associate will not be permitted to submit any **Bid Security (if applicable)** and Performance Security on behalf of their foreign principals and also the Indian Agent/Representative/Retainer/Associate will not be allowed to execute the contract and receive payment against bid submitted by their foreign principals. Such bids shall be rejected straightway.

### **15.0 Deadline for submission of bids:**

- 15.1 Bids should be submitted online as per the online tender submission deadline. Bidders will not be permitted by System to make any changes in their bid/quote after the bid submission deadline is reached. Bidders are requested to take note of this and arrange to submit their bids within the submission deadline to avoid last minute rush/network problems.
- 15.2 No bid can be submitted after the submission dead line is reached. The system time displayed on the e-procurement web page shall decide the submission dead line.
- 15.3 The documents in physical form as stated in Para 13.2 must be received by Company at the address specified in the "Forwarding Letter" on or before 12.45 Hrs(IST) on the Bid Closing Date mentioned in the "Forwarding Letter". Timely delivery of the same at the address mentioned in the Forwarding Letter is the responsibility of the Bidders.

### **16.0 Late Bids:**

- 16.1 Bidders are advised in their own interest to ensure that their bids are uploaded in system much before the closing date and time of the bid. The documents in physical form if received by the Company after the deadline for

**E-TENDER: CGI7847P25**

submission prescribed by the Company shall be rejected and shall be returned to the Bidders in unopened condition immediately.

**17.0 Modification and withdrawal of bids**

17.1 The Bidder after submission of Bid may modify or withdraw its Bid prior to Bid Closing Date & Time in the e-portal using Digital Signature by the person or persons who has/have digitally signed the Bid. Withdrawal or modification of bid through physical correspondence shall not be considered and accepted.

17.2 No Bid can be modified or withdrawn subsequent to the deadline for submission of Bids.

17.3 No Bid can be withdrawn in the interval between the deadline for submission of Bids and the expiry of the period of Bid Validity specified by the Bidder on the Bid Form. Withdrawal of a Bid during this interval shall result in the Bidder's debarment from participation in future tenders of OIL.

**18.0 Extension of bid submission date**

18.1 Normally no request for extension of Bid Closing Date & Time will be entertained. However, OIL at its discretion, may extend the Bid Closing Date and/or Time due to any reasons.

**19.0 Bid opening and evaluation**

19.1 Company will open the Technical Bids, including submission made pursuant to clause 15.0, in presence of Bidder's representatives who choose to attend at the date, time and place mentioned in the Forwarding Letter. However, an authorisation letter (as per Proforma-I) from the Bidder must be produced by the Bidder's representative at the time of Bid Opening. Unless this Letter is presented, the representative will not be allowed to attend the Bid Opening. The Bidder's representatives who are allowed to attend the Bid Opening shall sign a register evidencing their attendance. Only one representative against each Bid will be allowed to attend. In technical bid opening, only "Technical Attachment" will be opened. Bidders therefore should ensure that technical bid is uploaded in the "Technical Attachment" Tab Page only in the E-portal.

19.2 In case of any unscheduled holiday or Bandh on the Bid Opening Date, the Bids will be opened on the next full working day. Accordingly, Bid Closing Date / time will get extended up to the next working day and time.

## **E-TENDER: CGI7847P25**

- 19.3 Bids which have been withdrawn pursuant to clause 17.0 shall not be opened. Company will examine bids to determine whether they are complete, whether requisite Bid Securities have been furnished, whether documents have been digitally signed and whether the bids are generally in order.
- 19.4 At bid opening, Company will announce the Bidder's names, written notifications of bid modifications or withdrawal, if any, the presence of requisite Bid Security **(if applicable)**, and such other details as the Company may consider appropriate.
- 19.5 Normally no clarifications shall be sought from the Bidders. However, for assisting in the evaluation of the bids especially on the issues where the Bidder confirms compliance in the evaluation and contradiction exists on the same issues due to lack of required supporting documents in the Bid (i.e. document is deficient or missing), or due to some statement at other place of the Bid (i.e. reconfirmation of confirmation) or vice versa, clarifications may be sought by OIL. In all the above situations, the Bidder will not be allowed to change the basic structure of the Bid already submitted by them and no change in the price or substance of the Bid shall be sought, offered or permitted.
- 19.6 Prior to the detailed evaluation, Company will determine the substantial responsiveness of each bid to the requirement of the Bid Documents. For purpose of these paragraphs, a substantially responsive bid is one, which conforms to all the terms and conditions of the Bid Document without material deviations or reservation. A material deviation or reservation is one which affects in any substantial way the scope, quality, or performance of work, or which limits in any substantial way, in-consistent way with the Bid Documents, the Company's right or the bidder's obligations under the contract, and the rectification of which deviation or reservation would affect unfairly the competitive position of other bidders presenting substantial responsive bids. The Company's determination of Bid's responsiveness is to be based on the contents of the Bid itself without recourse to extrinsic evidence.
- 19.7 A Bid determined as not substantially responsive will be rejected by the Company and may not subsequently be made responsive by the Bidder by correction of the non-conformity.
- 19.8 The Company may waive minor informality or nonconformity or irregularity in a Bid, which does not constitute a material deviation, provided such waiver, does not prejudice or affect the relative ranking of any Bidder.

## **20.0 Opening of priced bids**

## **E-TENDER: CGI7847P25**

- 20.1 Company will open the Priced Bids of the techno-commercially qualified Bidders on a specific date in presence of representatives of the qualified bidders. The techno-commercially qualified Bidders will be intimated about the Priced Bid Opening Date & Time in advance. In case of any unscheduled holiday or Bandh on the Priced Bid Opening Date, the Bids will be opened on the next working day.
- 20.2 The Company will examine the Price quoted by Bidders to determine whether they are complete, any computational errors have been made, the documents have been properly signed, and the bids are generally in order.
- 20.3 Arithmetical errors will be rectified on the following basis. If there is a discrepancy between the unit price and the total price (that is obtained by multiplying the unit price and quantity) the unit price shall prevail and the total price shall be corrected accordingly. If there is a discrepancy between words, and figures, the amount in words will prevail. If any Bidder does not accept the correction of the errors, their Bid will be rejected.

### **21.0 Conversion to single currency**

While evaluating the bids, the closing rate (B.C. Selling Rate) of exchange declared by State Bank of India on the day prior to price bid opening will be taken into account for conversion of foreign currency into Indian Rupees. Where the time lag between the opening of the price bids and final decision exceeds three months, the rate of exchange declared by State Bank of India on the date prior to the date of final decision will be adopted for conversion.

### **22.0 Evaluation and comparison of bids**

The Company will evaluate and compare the bids as per **BID EVALUATION CRITERIA (BEC), PART-2** of the Bid Documents.

#### **22.1 Discounts / rebates**

- 22.1.1 Unconditional discounts/rebates, if any, given in the bid will be considered for evaluation.
- 22.1.2 Post bid or conditional discounts/rebates offered by any bidder shall not be considered for evaluation of bids. However, if the lowest bidder happens to be the final acceptable bidder for award of contract, and if they have offered any discounts/rebates, the contract shall be awarded after taking into account such discounts/rebates.

#### **22.2 Loading of foreign exchange**

There would be no loading of foreign exchange for deciding the inter-se-ranking of domestic bidders.

**22.3 Exchange rate risk**

Since Indian bidders are now permitted to quote in any currency and also receive payments in that currency, Company will not be compensating for any exchange rate fluctuations in respect of the services.

**22.4 Repatriation of rupee cost**

In respect of foreign parties rupee payments made on the basis of the accepted rupee component of their bid, would not be repatriable by them. A condition to this effect would be incorporated by the Company in the contract.

**23.0 Contacting the company**

23.1 Except as otherwise provided in Clause 19.0 above, no Bidder shall contact Company on any matter relating to its bid, from the time of the bid opening to the time the Contract is awarded except as required by Company vide sub-clause 19.5.

23.2 An effort by a Bidder to influence the Company in the Company's bid evaluation, bid comparison or Contract award decisions may result in the rejection of their bid.

**24.0 Award of contract**

24.1 Award criteria

24.1.1 The Company will award the Contract to the successful Bidder whose bid has been determined to be substantially responsive and has been determined as the lowest evaluated bid, provided further that the Bidder is determined to be qualified to perform the Contract satisfactorily.

**25.0 Company's right to accept or reject any bid**

Company reserves the right to accept or reject any or all bids and to annul the bidding process and reject all bids, at any time prior to award of contract, without thereby incurring any liability to the affected bidder, or bidders or any obligation to inform the affected bidder of the grounds for Company's action.

**26.0 Notification of award**

Prior to the expiry of the period of bid validity or extended validity, Company will notify the successful Bidder in writing by registered letter or by fax or E-mail (to be confirmed in writing by registered / couriered letter) that its Bid has been accepted.

26.1 The notification of award will constitute the formation of the Contract.

**E-TENDER: CGI7847P25**

26.2 Upon the successful Bidder's furnishing of Performance Security pursuant to Clause 27.0 below, the Company will promptly notify each un-successful Bidder and will discharge their Bid Security **(if applicable)**, pursuant to Clause 10.0 hereinabove.

**27.0 Performance security:**

Successful bidder has to submit Performance Security amount as mentioned in GCC clause no. 10.0 -

**28.0 Signing of contract**

28.1 At the same time as the Company notifies the successful Bidder that its Bid has been accepted, the Company will either call the successful Bidder for signing of the agreement or send the Contract Form provided in the Bid Documents, along with the General & Special Conditions of Contract, Technical Specifications, Schedule of Rates incorporating all agreements agreed between the two parties.

28.2 The successful Bidder shall sign and date the contract and return it to the Company after receipt of LOA. Till the contract is signed, the LOA issued to the successful bidder shall remain binding amongst the two parties.

28.3 In the event of failure on the part of the successful Bidder to sign the contract, OIL reserves the right to terminate the LOA issued to the successful Bidder and the party shall be debarred for a period of 2(two) years from the date of default.

*(Signing of the Contract may be done at the place of award in presence of both parties)*

**29.0 Credit facility**

Bidders should indicate clearly in the Bid about availability of any credit facility inclusive of Government to Government credits indicating the applicable terms and conditions of such credit.

**30.0 Mobilization and advance payment **(NOT APPLICABLE FOR THIS TENDER)****

30.1 Request for advance payment shall not be normally considered. However, depending on the merit and at the discretion of the Company, advance against mobilization charge may be given at an interest rate of 1% above the prevailing Bank rate (CC rate) of SBI from the date of payment of the advance till recovery/refund.

**E-TENDER: CGI7847P25**

- 30.2 Advance payment agreed to by the Company shall be paid only against submission of an acceptable bank guarantee whose value should be equivalent to the amount of advance plus the amount of interest covering the period of advance. Bank guarantee shall be valid for 2 months beyond completion of mobilization and the same may be invoked in the event of Contractor's failure to mobilize as per agreement.
- 30.3 In the event of any extension to the mobilization period, Contractor shall have to enhance the value of the bank guarantee to cover the interest for the extended period and also to extend the validity of bank guarantee accordingly.

**31.0 Integrity pact: APPLICABLE for this tender**

- 31.1 OIL shall be entering into an Integrity Pact with the Bidders as per format enclosed vide **Proforma I** of the Bid Document. The Integrity Pact has been duly signed digitally by OIL's competent signatory and uploaded in the OIL's e-portal. The Integrity Pact shall be returned by the bidder (along with the technical Bid) duly signed by the same signatory who signed the Bid i.e. who is duly authorized to sign the Bid. Uploading the Integrity Pact in the OIL's E-portal with digital signature will be construed that all pages of the Integrity Pact has been signed by the bidder's authorized signatory who has signed the bid. If any bidder refuses to sign Integrity Pact or declines to submit the Integrity Pact, their bid shall be rejected straightway.

- 31.2 Bidders may contact the Independent External Monitors for any matter relating to the IFB at the following addresses:

A. Shri Ram Phal Pawar, IPS (Retd.), Former Director, NCRB, MHA,  
E-mail IDs: rpawar61@hotmail.com , [ramphal.pawar@ips.gov.in](mailto:ramphal.pawar@ips.gov.in)

B. Dr. Tejendra Mohan Bhasin,  
Former Vigilance Commissioner, CVC  
E-mail: tmbhasin@gmail.com

C. Shri Ajit Mohan Sharan, IAS (Retd.)  
Former Secretary,  
Ministry of Ayush,  
Govt. of India  
E-mail: ams057@gmail.com

**32.0 Local conditions**

It is imperative for each Bidder to be fully informed themselves of all Indian as well as local conditions, factors and legislation which may have any effect on the execution of the work covered under the Bidding Document. The

## **E-TENDER: CGI7847P25**

bidders shall be deemed, prior to submitting their bids to have satisfied themselves of all the aspects covering the nature of the work as stipulated in the Bidding Document and obtain for themselves all necessary information as to the risks, contingencies and all other circumstances, which may influence or affect the various obligations under the Contract.

No request will be considered for clarifications from the Company (OIL) regarding such conditions, factors and legislation. It is understood and agreed that such conditions, factors and legislation have been properly investigated and considered by the Bidders while submitting the Bids. Failure to do so shall not relieve the Bidders from responsibility to estimate properly the cost of performing the work within the provided timeframe. Company (OIL) will assume no responsibility for any understandings or representations concerning conditions made by any of their officers prior to award of the Contract. Company (OIL) shall not permit any Changes to the time schedule of the Contract or any financial adjustments arising from the Bidder's lack of knowledge and its effect on the cost of execution of the Contract.

### **33.0 Specifications**

Before submission of Bids, Bidders are requested to make themselves fully conversant with all Conditions of the Bid Document and other relevant information related to the works/services to be executed under the contract.

### **34.0** In all National Competitive tenders, only Class-I local suppliers and Class-II local suppliers shall be eligible to bid. **[NOT APPLICABLE FOR THIS TENDER]**.

[Class-I local supplier' means a supplier or service provider, whose goods, services or works offered for procurement, has local content equal to or more than 50% as defined in PP-LC policy; Class-II local supplier': means a supplier or service provider, whose goods, services or works offered for procurement, has local content equal to or more than 20% but less than 50%, as defined under PP-LC policy].

### **35.0** Upon award of Contract based on PP-LC policy, the bidder shall have to submit additional Bank Guarantee (format enclosed as PROFORMA-XV) equivalent to the amount of Performance Security towards fulfillment of conditions pertaining to Local Contents in accordance with the value mentioned in the certificate of LC. **[ NOT APPLICABLE FOR THIS TENDER]**

### **36.0** **The bidders have to categorically confirm / declare the policy i.e. PP-LC or PP-MSE** under which they want to avail the benefit and have to submit relevant supporting document / certificate to avail this benefit. The bids will be evaluated based on this declaration. No benefit will be given if the bid is submitted without the above declaration along with supporting document as per the respective policies. Availing the benefit of Purchase Preference and award of eligible tendered

## **E-TENDER: CGI7847P25**

quantity after price matching, shall be considered based on Bidder's declaration of availing PP-LC or MSE policy only. Bidder(s) shall declare the purchase preference policy they have opted in **PROFORMA-XVII. [NOT APPLICABLE FOR THIS TENDER].**

**37.0** Purchase preference policy (linked with Local Content) (PP-LC) notified vide letter no. FP-20013/2/2017-FP-PNG dated 17th November, 2020 of MoP&NG ,Order No. FP20013/2/2017-FP-PNG-Part (4) (E-41432) dated 26th April 2022 of MoPNG, FP- 20013/2/2017-FP-PNG-Part(1) E(-36682) dated 23.02.2022 of MoP&NG.Purchase preference policy (linked with Local Content) (PP-LC) **(Applicable for tenders of value greater than Rs 1 Crore.) [NOT APPLICABLE FOR THIS TENDER]**

### 1 Preamble

1.1 In tune with Make in India (MII) campaign in oil and gas sector, the Government has decided to incentivize the growth in local content in goods and services while implementing oil and gas projects in India, and

1.2 Whereas the Public procurement policy rests upon the core principles of competitiveness, adhering to sound procurement practices and execution of orders for supply of goods or services in accordance with a system which is fair, equitable, transparent, competitive and cost effective, and

1.3 Whereas, the local content can be increased through partnerships, cooperation with local companies, establishing production units in India or Joint Ventures (JV) with Indian suppliers, increasing the participation of local employees in services and training them etc.

1.4 Whereas incentivizing enhanced local content in the procurement of goods and/or services in oil and gas business activities would lead to increased local industry content;

1.5 Therefore, the Ministry of Petroleum and Natural Gas (MoPNG) has decided to stipulate the following policy for providing Purchase Preference to the manufacturers/ service providers having the capability of meeting/ exceeding the local content targets in oil and gas business activities;

1.6 This policy considers the Local Content (LC) as the added value brought to India through the activities of the oil and gas industry. This may be measured (by project, affiliate, and/or country aggregate) and undertaken through Workforce development and investments in supplier development through developing and procuring supplies and services locally.

### 2 Definitions

2.1 Oil and Gas Business Activity shall comprise of Upstream, Midstream and

## **E-TENDER: CGI7847P25**

Downstream business activities.

2.2 Domestic products shall be goods and/or service (including design and engineering), produced by companies, investing and producing in India.

2.3 Local Content hereinafter abbreviated to LC means the amount of value added in India which shall, unless otherwise prescribed by the Nodal Ministry, be the total value of the item procured (excluding net domestic indirect taxes) minus the value of imported content in the item (including all customs duties) as a proportion of the total value, in percent.

2.4 Domestic Manufacturer shall be business entity or individual having business activity established under Indian law and producing products domestically.

2.5 Supplier of goods and/or provider of service shall be a business entity having capability of providing goods and/or service in accordance with the business line and qualification thereof and classified as under:

'Class-I local supplier' means a supplier or service provider, whose goods, services or works offered for procurement, has local content equal to or more than 50% as defined under this Policy.

'Class-II local supplier' means a supplier or service provider, whose goods, services or works offered for procurement, has local content more than or equal to 20% but less than 50%, as defined under this Policy.

'Non-local supplier' means a supplier or service provider, whose goods, services or works offered for procurement, has local content less than 20%, as defined under this Policy.

2.6 Steering Committee means the committee to be constituted by MoPNG to provide effective guidance and to oversee the implementation of the Policy on a regular and continuing basis.

2.7 Verification shall be an activity to verify the accomplishment of LC by domestic manufacturers and/or suppliers of goods and/or providers of service with the data obtained or collected from respective business activities.

2.8 Purchase preference: Where the quoted price is within the margin of purchase preference of the lowest price, other things being equal, purchase preference may be granted to the bidder concerned, at the lowest valid price bid.

2.9 Local Content (LC) in Goods shall be the use of raw materials, design and engineering towards manufacturing, fabrication and finishing of work carried out within the country.

2.10 Local Content (LC) in Services shall be the use of services up to the final delivery by utilizing manpower (including specialist), working appliance (including software) and supporting facilities carried out within in the country.

2.11 Local Content (LC) in EPC contracts shall be the use of materials, design and

## **E-TENDER: CGI7847P25**

engineering comprising of manufacturing, fabrication, assembly and finishing as well as the use of services by utilizing manpower (including specialist), working appliance (including software) and supporting facility up to the final delivery, carried out within the country.

2.12 Factory overhead cost shall be indirect costs of manpower, machine/working appliance/facility and the whole other fabrication costs needed to produce a unit of product with the cost not chargeable directly to specified product.

2.13 Company overhead cost shall be costs related to the marketing, administration and general affairs cost of the company.

2.14 Indian Company means a company formed and registered under the Companies Act, 2013.

2.15 Foreign company means any company or body corporate incorporated outside India which-

(a) has a place of business in India whether by itself or through an agent, physically or through electronic mode; and (b) conducts any business activity in India in any other manner.

### **3. Scope**

3.1 The regulation shall be intended to:

3.1.1 Support and boost the growth of domestic manufacturing sector so as to be able to support oil and natural gas business activities and contribute added value to economy, absorb manpower as well as have national, regional and international competitiveness;

3.1.2 Support and boost the growth of innovation/technology of domestic manufacturing sector.

3.2 This policy shall apply to all the Public Sector Undertakings and their wholly owned subsidiaries under the Ministry of Petroleum and Natural Gas; Joint Ventures that have 51% or more equity by one or more Public Sector Undertakings under the Ministry of Petroleum and Natural Gas; attached and subordinate offices of MoPNG.

3.3 This policy shall not include goods/ services falling under Micro Small and Medium Enterprises (MSME) or Domestically Manufactured Electronic Products (DMEP), as those products/ services are already covered under specific policy. However, an option would be given in the tender for the bidder to declare preference for seeking benefit under PP-LC/MSME or DMEP.

3.4 The policy is not applicable for HP-HT operations for the time being. The Charter Hiring of offshore vessels shall continue to be governed by DG, Shipping Guidelines. Indian Flag Vessels shall be considered as having 100% LC.

3.5 The prescribed local content in the Policy shall be applicable on the date of Notice inviting Tender.

### **4. Procurement**

## **E-TENDER: CGI7847P25**

4.1 The procuring companies shall follow their own procurement procedures. Aggregation of annual requirements and such other procurement practices, which facilitate the implementation of this policy, may be adopted by procuring companies.

4.2 In respect of Global Tender Enquiry (GTE) the guidelines as issued by Government of India from time to time shall be applicable on the procuring entities.

4.3 **Margin of Purchase preference: The margin of purchase preference shall be 20%.**

4.4 (a) In respect of all goods, services or works in respect of which the Nodal Ministry/ Department under DPIIT's Public Procurement (Preference to Make in India) Order, 2017 has communicated that there is sufficient local capacity and local competition, only Class-I local supplier shall be eligible to bid irrespective of purchase value.

4.4 (b) For all other local tenders, Class-I local supplier and Class-II local supplier shall be eligible to bid irrespective of purchase value, but preference to be given as per PP-LC to the Class-I local supplier.

4.4 (c) Only Class-I local supplier and Class-II local supplier, as defined under the Order, shall be eligible to bid in procurements undertaken by procuring entities, except when Global tender enquiry has been issued. In global tender enquiries, Non-local suppliers shall also be eligible to bid along with Class-I local suppliers and Class-II local suppliers.

4.4 (d) Class-II local supplier will not get purchase preference in any procurement, undertaken by procuring entities.

4.5 **In National Competitive Bid procurements of all items not covered by para 4.4 (a) and where the estimated value to be procured i.e. total value of enquiry/ tender, is less than Rs. 1 Crore shall be exempt from this Policy.** In case of International Competitive Bids, the policy shall be applicable irrespective of the tender estimate. However, it shall be ensured by procuring entities that procurement is not split for the purpose of avoiding the provisions of this Policy.

4.6 The producers of goods and/or providers of services shall be obliged to fulfil the requirements of quality and delivery time in accordance with the provisions of the respective contracts of goods and services.

4.7 If the Ministry is satisfied that Indian suppliers of an item are not allowed to participate and/or compete in procurement by any foreign government, it may, if it deems appropriate, restrict or exclude bidders from that country from eligibility for procurement of that item and/or other items relating to the Ministry.

4.8 For the purpose of para 4. 7 above, a supplier or bidder shall be considered to be from a country if (i) the entity is incorporated in that country, or (ii) a majority of its shareholding or effective control of the entity is exercised from that country, or (iii) more than 50% of the value of the item being supplied has been added in that country. Indian suppliers shall mean those entities which meets any of these tests with respect

to India.

5. Purchase Preference- Linked with Local Content {LC}

5.1 In procurement of all items not covered by para 4.4 (a), the following provisions may be considered for LC linked Purchase Preference:

5.1.1 The manufacturers/ service providers having the capability of meeting/ exceeding the local content targets shall be eligible for purchase preference under the policy, i.e. LC manufacturers/ LC service providers respectively as described below.

5.1.2 Wherever the goods/ services are procured under this policy, eligible (techno-commercially qualified) Class I Local supplier may be granted a purchase preference where the quoted price is within the margin of purchase preference of the lowest price, other things being equal, purchase preference may be granted to the eligible (techno-commercially qualified) Class I Local supplier concerned, at the lowest valid price bid.

5.1.3 Goods: The tender for procuring goods would specify that the contract for 50% of the procured quantity would be awarded to the lowest techno-commercially qualified Class I Local supplier, subject to matching with L1, if such bidders are available. The remaining will be awarded to L1.

5.1.3.1 However, if L1 bidder happens to be a Class Local supplier, the entire procurement value shall be awarded to such bidder;

5.1.3.2 If in the opinion of the procuring company, the tenders (procured quantity) cannot be divided in the prescribed ratio of 50:50, then they shall have the right to award contract to the eligible Class I Local supplier for quantity not less than 50%, as may be divisible.

5.1.3.3 In continuation to 5.1.3.2 above, if the tendered item is non divisible, (to be included in the tender document by procuring company) the contract can be awarded to the eligible Class I Local supplier for the entire quantity.

5.1.4 **Services/ EPC Contracts: The tender for oil and gas services/ EPC contracts shall not normally be split. For such procurement the tender would specify that the entire contract would be awarded to the lowest techno-commercially qualified Class I Local supplier, subject to matching with L1, if such bidders are available.** However, tender for certain oil & gas services can normally be split, in such cases, splitting shall be allowed and specified in tender document. Such services shall follow the procedure outlined for goods as described in para 5.1.3. The procuring company should clearly specify in the tender document whether the tender shall be split or not.

5.1.5 For para 5.1.3 and 5.1.4 above, only those LC manufacturers/ service providers whose bids are within the margin of purchase preference would be allowed an opportunity to match L1 bid.

5.1.6 The tender conditions would ensure that local content in oil & gas products is encouraged. However, the procuring company may incorporate such stipulations as

**E-TENDER: CGI7847P25**

may be considered necessary to satisfy themselves of the production capability and product quality of the manufacturer.

**5.1.7 The procedure for award under the policy is at Enclosure-I.**

6. Determination of LC

6.1 LC of goods

6.1.1 LC of goods shall be computed on the basis of the cost of domestic components in goods, compared to the whole cost of product.

6.1.2 The criteria for determination of the local content cost in the goods shall be as follows:

- a) in the case of direct component (material), based on country of origin;
- b) in the case of manpower, based on INR component.

6.1.3 The calculation of LC of the combination of several kinds of goods shall be based on the ratio of the sum of the multiplication of LC of each of the goods · with the acquisition price of each good to the acquisition price of the combination of goods.

6.2 LC of service

6.2.1 LC of Service shall be calculated on the basis of the ratio of service cost of domestic component in service to the total cost of service.

6.2.2 The total cost of service--shall be constituted of the cost spent for rendering of service, covering:

- a) cost of component (material) which is used;
- b) manpower and consultant cost; cost of working equipment/ facility; and
- c) general service cost.

6.2.3 The criteria for determination of cost of local content in the service shall be as follows:

- a) in the case of material being used to help the provision of service, based on country of origin;
- b) in the case of manpower and consultant based on INR component of the services contract;
- c) in the case of working equipment/facility, based on country of origin; and
- d) in the case of general service cost, based on the criteria as mentioned in clauses a, b, and c above.
- e) Indian flag vessels in operation as on date.

## **E-TENDER: CGI7847P25**

### 6.3 LC of the EPC Contracts:

6.3.1 LC of EPC contracts shall be the ratio of the whole cost of domestic components in the combination of goods and services to the whole combined cost of goods and services.

6.3.2 The whole combined cost of goods and services shall be the cost spent to produce the combination of goods and services, which is incurred on work site. LC of the combination of goods and services shall be counted in every activity of the combination work of goods and services.

6.3.3 The spent cost as mentioned in paragraph 6.3.2 shall include production cost in the calculation of LC of goods as mentioned in clause 6.1.1 and service cost in the calculation of LC of services as mentioned in clause 6.2.2.

### 6.4 Calculation of LC and Reporting

LC shall be calculated on the basis of verifiable data. In the case of data used in the calculation of LC being not verifiable, the value of LC of the said component shall be treated as nil.

## 7 Certification and Verification

7.1 Class I/Class II Local suppliers are eligible to bid only if they meet the local content norms, therefore whether or not they want to avail PP-LC benefit, it will still be mandatory for them to give adequate documentation as follows to establish their status as Class-I or Class-II local supplier

### 7.1.2 At bidding stage:

#### a. Price Break-up:

- The bidder shall provide the percentage of local content in the bid
- b) The bidder shall submit an undertaking from the authorized signatory of bidder having the power of Attorney along with the bid stating the bidder meets the mandatory minimum LC requirement and such undertaking shall become a part of the contract.

- In cases of procurement for a value in excess of Rs 10 crores, the undertaking submitted by the bidder shall be supported by a certificate from the statutory auditor or cost auditor of the company (in case of companies) or from a practicing cost accountant or practicing chartered accountant (in respect of other than companies) giving the percentage of local content.

- However, in case of foreign bidder, certificate from the statutory auditor or cost auditor of their own office or subsidiary in India giving the percentage of local content is also acceptable. In case office or subsidiary in India does not exist or Indian office/ subsidiary is not required to appoint statutory auditor or cost auditor, certificate from practicing cost accountant or practicing chartered accountant giving the percentage of

## **E-TENDER: CGI7847P25**

local content is also acceptable.

### 7.1.3 After Contract Award:

- The bidder shall submit an undertaking from the authorized signatory of bidder having the power of Attorney along with the bid stating the bidder meets the mandatory minimum LC requirement and such undertaking shall become a part of the contract.
- In cases of procurement for a value in excess of Rs 10 crores, the undertaking submitted by the bidder shall be supported by a certificate from the statutory auditor or cost auditor of the company (in case of companies) or from a practicing cost accountant or practicing chartered accountant (in respect of other than companies) giving the percentage of local content.
- However, in case of foreign bidder, certificate from the statutory auditor or cost auditor of their own office or subsidiary in India giving the percentage of local content is also acceptable. In case office or subsidiary in India does not exist or Indian office/ subsidiary is not required to appoint statutory auditor or cost auditor, certificate from practicing cost accountant or practicing chartered accountant giving the percentage of local content is also acceptable.

7.2 Each supplier shall provide the necessary local-content documentation to the statutory auditor, which shall review and determine that local content requirements have been met, and issue a local content certificate to that effect on behalf of the bidder, stating the percentage of local content in the good or service measured. The Auditor shall keep all necessary information obtained from suppliers for measurement of Local Content confidential.

7.3 The Local Content certificate shall be submitted along with each invoice raised. However, the % of local content may vary with each invoice while maintaining the overall % of local content for the total work/purchase of the pro-rata local content requirement. In case, it is not satisfied cumulatively in the invoices raised up to that stage, the supplier shall indicate how the local content requirement would be met in the subsequent stages.

7.4 As regards cases where currency quoted by the bidder is other than Indian Rupee, exchange rate prevailing on the date of notice inviting tender (NIT) shall be considered for the calculation of Local Content.

7.5 The Procuring Company shall also have the authority to audit as well as witness production processes to certify the achievement of the requisite local content.

## 8 Governance and Supervision

**E-TENDER: CGI7847P25**

8.1 A Steering Committee will be constituted by MoPNG to provide effective guidance and to oversee the effective implementation of the Policy including review and amendments required therein. The Steering Committee may consider representations on target Local Content in goods, services and EPC and modify the policy accordingly.

8.2 The Steering Committee shall annually conduct a review of the policy implementation which shall specifically cover the issue of whether there has been adequate competition, and whether the policy has resulted in any reduction in competition/ exclusion of non-local bidders or any cost increase to the purchasing PSU, particularly-in respect of services & works contracts.

9 Sanctions

9.1 The Procuring companies shall impose sanction on manufacturers/ service providers not fulfilling LC of goods/ services in accordance with the value mentioned in certificate of LC.

9.2 The sanctions may be in the form of written warning, financial penalty and blacklisting.

9.3 In the event that a manufacturer or supplier of goods and/or provider of services does not fulfil his obligation after the expiration of the period specified in such warning, the procuring company can initiate action for blacklisting such manufacturer/supplier/service provider.

9.4 A manufacturer and/or supplier of goods and/or provider of services who has been awarded the contract after availing Purchase Preference is found to have violated the LC provision, in the execution of the procurement contract of goods and/or services shall be subject to financial penalty specified in clause 9.4.1.

9.4.1 The financial penalty shall be over and above the PBG value prescribed in the contract and shall not be more than an amount equal to 10% of the Contract Price.

10. Clarification on Goods/ Services: Any issue regarding the coverage of a particular good/ service under the proposed policy would be referred to the Steering Committee for clarification.

11. Powers to grant exemption and to reduce minimum local content: Wherever proper justification exists, Ministry of Petroleum and Natural Gas may by written order, for reasons to be recorded in writing,

- a) Reduce the minimum local content below the prescribed level; or
- b) Reduce the margin of purchase preference below 20%; or
- c) Exempt any particular item or supplying entities from the operation of this Order or any part of the Order.

12. Time Period: The Policy shall be applicable for 5 years. Except for 2017-18, the Policy shall not be continued unless, the Steering Committee by September 30th of each year, concludes a review as per para 8.2 of the Policy and recommends continuation of the Purchase Preference.

**Enclosure-I**

**PROCEDURE FOR AWARD OF CONTRACTS**

Procedure for award of contracts under this policy shall be as follows:

1.1 In procurement of all items which are divisible in nature, the 'Class I local supplier' shall get purchase preference over 'Class II local supplier' as well as 'Non Local Supplier' as per following procedure:

- i. Among all qualified bids, the lowest bid will be termed as L1. If L1 is 'Class I local supplier', the contract for full quantity will be awarded to L1.
- ii. If L1 bid is not a 'Class I local supplier', 50% of the order quantity shall be awarded to L1. Thereafter, lowest bidder among the 'Class I Local supplier' will be invited to match the L1 price for the remaining 50% quantity subject to Class I local supplier's quoted price failing within the margin of purchase preference, and contract for that quantity shall be awarded to such 'Class I local supplier' subject to matching the L1 price. In case such lowest eligible 'Class I local supplier' fails to match the L1 price or accepts less than the offered quantity, the next higher 'Class I local supplier' within the margin of purchase preference shall be invited to match the L1 price for remaining quantity and so on, and contract shall be awarded accordingly. In case some quantity is still left uncovered on Class I local suppliers, then such balance quantity may also be ordered on the L1 bidder.

1.2 In the procurement of all items which are not divisible in nature, and in procurement of services where the bid is evaluated on price alone, the 'Class I local supplier' shall get purchase preference over 'Class II local supplier' as well as 'Non-local supplier', as per following procedure:

- i. Among all qualified bids, the lowest bid will be termed as L1. If L1 is 'Class-I local supplier', the contract will be awarded to L1.
- ii. If L1 is not 'Class-I local supplier', the lowest bidder among the 'Class-I local supplier', will be invited to match the L1 price subject to Class-I local supplier's quoted price falling within the margin of purchase preference, and the contract shall be awarded to such 'Class-I local supplier' subject to matching the L1 price.
- iii. In case such lowest eligible 'Class-I local supplier' fails to match the L1 price, the 'Class-I local supplier' with the next higher bid within the margin of purchase preference shall be invited to match the L1 price and so on and contract shall be awarded accordingly. In case none of the 'Class-I local supplier' within the margin of purchase preference matches the L1

**E-TENDER: CGI7847P25**

price, the contract may be awarded to the L1 bidder.

**38.0 DOCUMENTS REQUIRED TO BE SUBMITTED BY MSE BIDDERS:**

Categorization and various criteria applicable to MSE bidders shall be guided by the Gazette Notification No. CG-DL-E-26062020-220191 dated 26.06.2020 (and as amended time to time) issued by MINISTRY OF MICRO, SMALL AND MEDIUM ENTERPRISES and as amended time to time.

The bidder claiming the MSE status (MSE-General, MSE-SC/ST, MSE-Woman) against this tender must submit the following documents along with the technical bid for availing the benefits applicable to MSEs.

- i. Udyam Registration Number with Udyam Registration Certificate.**

**Note: In case bidding MSE is owned by Schedule Caste or Schedule Tribe or Woman entrepreneur, valid documentary evidence issued by the agency who has registered the bidder as MSE owned by SC/ST/Woman entrepreneur should also be enclosed.**

\*\*\*\*\*

**BID REJECTION CRITERIA(BRC) / BID EVALUATION CRITERIA (BEC)**

The bid shall conform generally to the specifications and terms and conditions given in the Bidding Documents. Bids will be rejected in case material and services offered do not conform to the required parameters stipulated in the technical specifications. Notwithstanding the general conformity of the bid to the stipulated specifications, the following requirements will have to be particularly met by the Bidders without which the same will be considered as non-responsive and rejected. Bidders are advised not to take any exception/deviations to the bid document. All the documents related to BEC/BRC shall be submitted along with the Techno-Commercial Bid.

**EXPERIENCE & FINANCIAL CRITERIA**

**1.0 BID REJECTION CRITERIA (BRC):**

The bid shall conform to the specifications and terms and conditions given in the Bidding Documents. Bids will be rejected in case material and services offered do not conform to the required parameters stipulated in the technical specifications. Notwithstanding the general conformity of the bid to the stipulated specifications, the following requirements will have to be particularly met by the Bidders without which the same will be considered as non-responsive and rejected. All the documents related to BRC shall be submitted along with the Bid.

**2.0. TECHNICAL:**

**2.1** The bidder must have successfully executed/completed similar Works over the last 7(seven) years reckoned from the Original Bid Closing Date in Central/State Government/ PSUs/ Nationalised Banks/ Public Limited Company as under -

The Bidders must have successfully executed/completed similar works (similar works mean "experience for execution of either Maintenance or laying of Optical Fibre Cable") over the last 7(seven) years reckoned from the original bid closing date in Central/ State Government/ PSUs/ Nationalised Banks/ Public Limited Company” as under:

(i) At least one similar work of **INR 16,46,180.**

NOTE-:

(a) A job executed by a bidder for its own organization / subsidiary cannot be considered as experience for the purpose of meeting BEC.

(b) In case of tenders for Annual rate contracts / Maintenance and Service contracts, if the prospective bidder is executing rate / maintenance /service contract which is still running and the contract value / quantity executed prior to due date of bid

## **E-TENDER: CGI7847P25**

submission is equal to or more than the minimum prescribed value in the BEC such experience will also be taken in to consideration provided that the bidder has submitted satisfactory work / supply / service execution certificate issued by end user.

2.2 Documentary proof must be furnished in support of the experience by way of purchase order / work order / contract document along with completion certificate from the organization to whom such services have been rendered.

In case of OIL contractor, copy of certificate of completion (COC)/Work Order showing gross value of job. It may be clearly noted that simply mentioning of OIL COC/WO no. will not be accepted.

2.3 Bidders must have PF Account in their name issued by Regional Provident Fund Commissioner. Documentary evidence of the same is to be submitted.

### 3.0 FINANCIAL

1.1 Financial capability: Bidders must have:

- i. Annual financial turnover as per Audited Annual Reports in any of the preceding three (3) financial years should be at least **INR 16,46,180.00**.
- ii. Period for consideration: In any of preceding 3 financial years
- iii. Net worth: Positive for the preceding financial / accounting year
- iv. For proof of Annual Turnover & Net worth any one of the following document must be submitted along with the bid:-

a) A certificate issued by a practicing Chartered/Cost Accountant (with Membership Number and Firm Registration Number), UDIN certifying the Annual turnover & Net worth.

**OR**

b) Audited Balance Sheet along with Profit & Loss account.

v. In case the bidder is a Central Govt. Organization/PSU/State Govt. Organization/Semi State Govt. Organization or any other Central/State Govt. Undertaking, where the auditor is appointed only after the approval of Comptroller and Auditor General of India and the Central Government, their certificates may be accepted even though FRN (Firm Registration Number) is not available. However, bidder to provide documentary evidence for the same.

vi. ~~Considering the time required for preparation of Financial Statements, if the last date of preceding financial/ accounting year falls within the preceding six months reckoned from the original bid closing date and the Financial Statements of the preceding financial / accounting year are not available with the bidder, then the financial turnover of the previous three financial / accounting years excluding the preceding financial / accounting year will be considered. In such cases, the Net worth~~

## E-TENDER: CGI7847P25

~~of the previous financial/ accounting year excluding the preceding financial/ accounting year will be considered. However, the bidder has to submit an affidavit/ undertaking certifying that the balance sheet/ Financial Statements for the financial year \_\_\_\_\_ (or as the case may be) has actually not been audited so far.~~

### 4. COMMERCIAL:

4.1. Bidder shall submit the offer under **Single Stage Single bid (Composite) system**. The tender is invited under **SINGLE STAGE SINGLE BID SYSTEM**. The bidders shall submit both the "TECHNICAL" and "PRICED" bids through electronic form in the OIL's E-Procurement portal within the Bid Closing Date and Time stipulated in the E-Tender. The Technical Bid should be submitted as per Scope of Work & Technical Specifications along with all technical documents related to the tender and uploaded under "Technical Attachment" Tab only. Bidders must note that no price details should be uploaded in "Technical Attachment" Tab Page. **The Technical Bid should not have any price indication otherwise, the bid shall be rejected straightway.** Details of prices as per Price Bid format/ Priced bid to be uploaded under "Notes and Attachment" Tab. **Bidders must quote clearly and strictly in accordance with the price schedule outlined in relevant section of Bidding Documents; otherwise the bid will be rejected.**

**Offer not complying with above submission procedure will be rejected as per Bid Rejection Criteria. In Bid opening, both Technical & Priced Bids will be opened. In Bid opening, Technical Bid will be opened. Priced Bid opening will be notified in OIL E TENDER portal.**

4.2. Bidder shall furnish **Bid Security(if applicable)/ DECLARATION FOR BID SECURITY(if applicable)** along with Bid. **Bid Security/DECLARATION FOR BID SECURITY** shall be furnished as a part of 'Technical Bid'. **Any bid not accompanied by a proper Bid Security(if applicable)/ DECLARATION FOR BID SECURITY(if applicable) will be rejected. Bidder shall submit original document to the address as specified with BCD before Bid opening date and time, otherwise Bid will be rejected.** A scanned copy of this document should also be uploaded along with the Un-priced bid.

EMD/Bid security is **applicable** against this tender and may be paid in the form of Demand Draft/Banker Cheque /Bank Guarantee **(as per Proforma-D) DECLARATION FOR BID SECURITY(if applicable) is to be furnished by the bidders along with the technical RFx in case of seeking exemption from submission of Bid security/ EMD(if applicable) (as per Proforma-R).**

Any offer not accompanied with the Bid Security**(if applicable)** shall be treated as invalid and summarily rejected unless the bidder is exempted from submission of Bid Security as per Bid Security Exemption Criteria of this tender and proper proof towards this exemption is submitted by the bidder. Any subsequent deposit of Bid Security**(if applicable)** after the bid closing date shall not be permitted. Also, adjustment of Bid Security**(if applicable)** due against the instant tender, against dues from the Company or on any account shall not be permitted.

**E-TENDER: CGI7847P25**

4.3. The Validity of the bid shall be **minimum 90 days from actual bid closing /opening date**. Bids with lesser validity will be rejected.

4.4. Any bid received in the form of Telex/Cable/Fax/E-mail/ Telephone call will not be accepted.

**4.5. Price quoted by the successful Bidder must be firm during the performance of the Contract and not subject to variation on any account. A bid submitted with an adjustable price will be treated as non-responsive and rejected.**

4.6. Any bid containing false statement will be rejected.

4.7. The Bid Documents are not transferable. Bids made by parties who have not purchased the Bid Documents from the Company will be rejected.

4.8. Any Bid received by the Company after the deadline for submission of bids prescribed by the Company will be rejected.

4.9. The following Clauses with all its sub-clauses should be agreed in toto, failing which the bid will be rejected. To this effect Bidder shall submit an undertaking along with the Technical Bid.

- a) Performance Security Clause
- b) Force Majeure Clause
- c) Termination Clause
- d) Settlement of disputes Clause
- e) Liquidated Damages Clause.
- f) Acceptance of Jurisdiction and applicable law.
- g) Tax liabilities clause.
- h) Insurance clause.
- i) With holding clause.
- j) Liability clause.
- k) Set off clause

**4.10 PURCHASE PREFERENCE CLAUSE:**

**PURCHASE PREFERENCE TO MSE BIDDERS:** Purchase Preference to Micro and Small Enterprises is applicable for this tender. Bidders seeking benefits, under Purchase Preference Policy (MSE) shall have to be registered under Udyam Registration.

- a) Purchase Preference to Micro and Small Enterprises (MSEs) falling within the price band of **L-1+ 15%** and ~~Purchase preference policy linked with Local Content (PP-LC) falling within the price band of L-1+ 20%~~ shall be applicable in this tender.
- b) In case a bidder is eligible to seek benefits under PP-LC policy as well as Public Procurement Policy for MSEs -

**E-TENDER: CGI7847P25**

Order 2012, then the bidders should categorically seek benefits against only one of the two policies i.e. either **PP- LC or MSE policy**. Bidder to categorically confirm under which policy i.e. **PP-LC or MSE**, they want to avail the benefit and to submit requisite document/certificate in support to avail this benefit. The bids shall be evaluated based on their declaration. No benefit shall be given if the bid is submitted without any above declaration along with supporting document as per the respective policies. Please refer **PROFORMA-XVII** to confirm under which category (PPLC or MSE) the benefit has been sought. **(NOT APPLICABLE FOR THIS TENDER)**

In case participating MSEs Quote price within price band of L1+15%, such MSE shall be considered for award of contract by bringing down their price to L1 price in a situation where L1 price is from someone other than an MSE.

In case of more than one such MSE qualifying for 15% purchase preference, the contract shall be awarded to lowest eligible MSE amongst the MSEs qualifying for 15% purchase preference.

Documentation required to be submitted by MSEs: Categorization and various criteria applicable to MSE bidders shall be guided by the Gazette Notification No. CG-DL- E-26062020-220191 dated 26.06.2020.

The bidder claiming the MSE status (MSE-General, MSE-SC/ST, MSE-Woman) against this tender must submit the following documents along with the technical bid for availing the benefits applicable to MSEs.

**(i) Udyam Registration Number with Udyam Registration Certificate.**

Note: In case bidding MSE is owned by Schedule Caste or Schedule Tribe or Woman entrepreneur, valid documentary evidence issued by the agency who has registered the bidder as MSE owned by SC/ST/Woman entrepreneur should also be enclosed.

**b) PURCHASE PREFERENCE POLICY (LINKED WITH LOCAL CONTENT) (PP- LC): (NOT APPLICABLE FOR THIS TENDER)**

i) Purchase preference policy-linked with Local Content (PP- LC) notified vide letter no. FP-20013/2/2017-FP-PNG dated 17th November, 2020 of MoPNG & Order No. FP20013/2/2017-FP-PNG-Part (4) (E-41432) dated 26th April 2022 of MoPNG shall be applicable in this tender. Bidders to check the provisions of the Notification for their eligibility to bid and seek benefits for Purchase preference, accordingly. Purchase preference will be applicable as per the Notification(s) and any amendment thereof. Bidders seeking benefits, under Purchase Preference Policy (linked with Local Content) (PP-LC) shall have to comply with all the provisions of the notification no. FP-20013/2/2017-FP-PNG dated 17th November, 2020 & Order No. FP20013/2/2017-

**E-TENDER: CGI7847P25**

FP-PNG-Part (4) (E-41432) dated 26th April 2022 of MoPNG or subsequent amendments, if any.

ii) Upon award of Contract based on PP-LC policy, the bidder shall have to furnish their compliance to all the provisions of PP-LC policy and to submit additional 10% Bank Guarantee of the total Contract value (format enclosed as PROFORMA-XV) towards fulfilment of conditions pertaining to Local Contents in accordance with the value mentioned in the certificate of LC.

**c) AWARD OF CONTRACT: The total requirement of hiring tendered services is not splittable/not divisible under the Purchase Preference policy.**

**In case of participation of both MSE and LC bidder(s) against the tender, MSE bidder(s) will be given preference over LC bidder(s) to match with L1 bidder as per Public Procurement Policy.** Accordingly, Purchase preference shall be extended as per the following:

a) Purchase preference will be given to MSEs as defined in Public Procurement Policy for Micro and Small Enterprises (MSEs) Order, 2012 dated 23.03.2012 issued by Ministry of Micro, Small and Medium Enterprises and its subsequent Orders/Notifications issued by concerned Ministry. If the bidder wants to avail the Purchase preference for services, the bidder must be the Service provider of the offered Service. Relevant documentary evidence in this regard shall be uploaded along with the bid in respect of the offered service. **If L-1 is not an MSE and MSE Service Provider (s) has/have quoted price within L-1+ 15% of margin of purchase preference/price band defined in relevant policy, then 100% order quantity will be awarded to such MSE bidder(s) subject to acceptance of L1 bid price.**

b) **In case of non-eligible MSE bidder (s): (NOT APPLICABLE FOR THIS TENDER)**

i) **Among all qualified bids, the lowest bid will be termed as L1. If L1 is “Class-I local supplier”, the contract for full quantity will be awarded to L1.**

(ii) **If L1 bidder is not a “Class-I local supplier”, the lowest bidder among the “Class-I local supplier” will be invited to match the L1 price subject to the Class-I local supplier’s quoted price falling within the margin of purchase preference, and the contract shall be awarded to such “Class-I local supplier” subject to matching the L1 price.**

(iii) **In case such lowest “Class-I local supplier” fails to match the L1 price, the next higher “Class-I local supplier” within the margin of purchase preference shall be invited to match the L1 price and so on and the contract shall be awarded accordingly. In case none of the “Class-I local supplier” within the margin of purchase preference matched the L1 price, the contract may be awarded to the L1 bidder.**

**4.11 There should not be any indication of price in the Un-priced Techno-Commercial Bid. A bid will be straightway rejected if this is given in the Un-priced Techno- Commercial Bid.**

## **E-TENDER: CGI7847P25**

4.12 **Bid received with validity of offer less than 120 (One Hundred Twenty) days from Bid Closing Date will be rejected.** Bidder must submit a declaration regarding bid validity as per the format prescribed in PROFORMA-B.a)

4.13 **The Integrity Pact is applicable against this tender.** OIL shall be entering into an Integrity Pact with the bidders as per format enclosed vide of the tender document. This Integrity Pact Proforma has been duly signed digitally by OIL's competent signatory. The Proforma has to be returned by the bidder (along with the Un-priced Techno-Commercial Bid) duly signed (digitally) by the same signatory who signed the bid, i.e., who is duly authorized to sign the bid. Uploading the Integrity Pact with digital signature will be construed that all pages of the Integrity Pact has been signed by the bidder's authorized signatory who sign the Bid. If any bidder refuses to sign Integrity Pact or declines to submit the Integrity Pact, their bid will be rejected.

4.14 Only one bid against a party offering individually as well as under Proprietorship/Partnership firms shall be accepted. In case any bidder is found to have submit separate bids under proprietorship as well as under any Partnership firm then the acceptable bid made in the name of the Partnership firm will only be considered for further evaluation.

### **5. BID EVALUATION CRITERIA (BEC):**

5.1. The bids conforming to the technical specifications, terms and conditions stipulated in the bid documents and considered to be responsive after subjecting to the Bid Rejection Criteria will be considered for further evaluation as per the Bid Evaluation Criteria.

5.2. To ascertain the inter-se-ranking, the comparison of the responsive bids will be made on the basis of total cost of various works envisaged under the contract.

5.3. In case more than one bidder emerges as lowest bidder due to equal rate quoted by the bidder, then the lowest bidder will be decided by draw of lots. Company's decision in this regard is final and binding to all bidders

5.4. Any discount/rebates offered shall not be considered for evaluation of bids. However, if the lowest bidder happens to be the final acceptable bidder for award of contract and if they have offered any discount/rebate the contract shall be awarded after taking into consideration such discount/rebate after negotiation or otherwise.

**5.5 Original Bid closing date will be considered for evaluation of BRC criteria even in case of any extension of the original Bid Closing Date.**

### **6.0 PRICE EVALUATION CRITERIA:**

6.1 Price bid shall be opened in respect of only the techno- commercially acceptable bidders whose bids have been found to be substantially responsive. A substantially responsive bid is one that meets the terms and conditions of the Tender and/or the acceptance of which bid will not result in indeterminate liability on OIL.

6.2 Bidders are required to quote for all the items as per Price Bid Format; otherwise the offer of the bidder will be straightway rejected.

**6.3 Arithmetical errors will be rectified on the following basis: If there is a discrepancy between the unit price and the total price (that is obtained by**

## E-TENDER: CGI7847P25

**multiplying the unit price and quantity) the unit price shall prevail and the total price shall be corrected accordingly. If there is a discrepancy between words, and figures, the amount in words will prevail. If any Bidder does not accept the correction of the errors, their Bid will be rejected.**

6.4 It is to be clearly understood that the assumptions made in respect of the quantities for various operations are only for the purpose of evaluation of the bid and the Contractor will be paid on the basis of the actual number of days/parameter, as the case may be.

6.5 The bidders are advised not to offer any discount/rebate separately and to offer their prices after considering discount/rebate, if any.

6.6 Conditional and unsolicited discount will not be considered in evaluation. However, if such bidder happens to be the lowest recommended bidder, unsolicited discount without any condition will be considered for computing the contract price.

6.7 **The inter-se-ranking of the techno-commercially qualified bidders will be determined on overall lowest cost basis (L-1 offer)** i.e. considering the Total quoted price inclusive of all liabilities and GST.

6.8 In case more than one bidder emerges as lowest bidder due to equal rate quoted by the bidder, then the lowest bidder will be decided by draw of lots. Company's decision in this regard is final and binding to all bidders.

6.9 OIL will prefer to deal with registered bidder under GST. Therefore, bidders are requested to get themselves registered under GST, if not registered yet. However, in case any unregistered bidder is submitting their bid, their prices will be loaded with applicable GST while evaluation of bid. Where OIL is entitled for input credit of GST, the same will be considered for evaluation of bid as per evaluation methodology of tender document.

6.10 Input Tax Credit on GST (Goods & Service Tax) for this service is NOT available to OIL & the bids will be evaluated based on total price including GST.

6.11 **Based on the evaluation of techno-commercially qualified bidders, the job will be awarded to L-1 bidder.**

## 7.0 OTHER INFORMATION /DOCUMENTS:

Other Information /Documents:

Bidders must furnish the following information with relevant documents wherever necessary:

- a) Tax Exemption Certificate, if any if /applicable.
- b) PAN no. (photocopy of the PAN card required).
- c) Goods & Service Tax registration no.
- e) Bank account no. with name of Bank, Type of account, Bank address.
- f) P.F. Account No./ Code
- g) ESI Account No./Code, if applicable

**E-TENDER: CGI7847P25**

h). GST REGISTRATION NO.

Non Furnishing of the above information may be liable for rejection of the offer.

**8.0 GENERAL:**

a) In case bidder takes exception to any clause of Tender Document not covered under BEC/BRC, then the Company has the discretion to load or reject the offer on account of such exception if the bidder does not withdraw/modify the deviation when/as advised by the Company. The loading so done by the Company will be final and binding on the Bidders. No deviation will however, be accepted in the clauses covered under BRC.

**b) To ascertain the substantial responsiveness of the bid the Company reserves the right to ask the Bidder for clarification in respect of clauses covered under BRC also such clarification fulfilling the BRC clauses must be received on or before ten days from the date of clarification sought by the Company, failing which the bid will be summarily rejected.**

c) In case of any of the clauses in the BRC contradict with other clauses of Bid Document elsewhere, then the clauses in the BRC shall prevail.

d) Any exceptions/deviations to the tender and applicable statutory duties and levies must be spelt out by bidder in their Techno-Commercial bid only.

d) The original copy of documents [furnished by bidders(s)] shall have to be produced by bidder(s) to OIL as and when asked for.

e) Bidder(s) must note that requisite information(s)/financial values etc. as required in the BEC/BRC & Tender are clearly understandable from the supporting documents submitted by the Bidder(s); otherwise Bids shall be rejected.

f) OIL will not be responsible for delay, loss or non-receipt of applications for participating in the bid sent by mail and will not entertain any correspondence in this regard.

g) The originals of such documents [furnished by bidder(s)] shall have to be produced by bidder(s) to OIL as and when asked for.

**h) In case, if L-1 bidder happens to be more than one, contract will be awarded on the basis of draw of lots.**

**9.0 COMPLIANCE OF THE COMPETITION ACT, 2002:** The bidder shall strictly comply with the provisions of the Competition Act, 2002, more particularly, Section-3 of the Act. Any violation of the provisions of the Act shall attract penal action under the Act.

**10.0 LAND BORDER SHARING:** Bidders should submit an Undertaking that, their bid is compliant to Order No. F.No. 6/18/2019-PPD dated 23.07.2020 issued by Ministry of Finance, Department of Expenditure, Public Procurement Division, Govt. of India (including subsequent amendments thereto, if any), regarding restrictions on procurement from a bidder of a country which shares land border with India.

**ANNEXURE-AA:**

**CERTIFICATE OF ANNUAL TURNOVER & NETWORTH**

(To be issued by practicing Chartered/Cost Accountant Firm  
on their Letter Head)

**E-TENDER: CGI7847P25**

TO WHOM IT MAY CONCERN

This is to certify that the following financial positions extracted from the audited financial statement of M/s\_\_\_\_\_ (Name of the bidder) for the last three(3) completed accounting years up to\_\_\_\_\_ (as the case may be) are correct.

<b>YEAR</b>	<b>TURNOVER(Rs.)</b>	<b>NETWORTH(Rs.)</b>
<b>2021-2022</b>		
<b>2022-2023</b>		
<b>2023-2024</b>		

Place:

Date:

Seal:

Membership Code and Registration No.

UDIN:

Signature:

\*\*\*\*End of BRC-BEC\*\*\*\*

**PART-3, SECTION-I**

**GENERAL CONDITIONS OF CONTRACT (GCC)**

**OIL INDIA LIMITED**  
**(A Government of India Enterprise)**  
**CONTRACTS DEPTT., PHQ**  
**P.O. Udayan Vihar – 781171, Guwahati, ASSAM**

**DESCRIPTION OF WORK/SERVICES:-**

**Maintenance of OFC cable and other Telecom activities for a period of two years extendable by another one year upon review under PS5 Sector(ROW Chainage PLKM 352-497 & Spur Line PHQ - GHY Refinery Termianl)**

**GENERAL CONDITIONS OF CONTRACT (GCC)**

**1.0 APPLICABILITY, DEFINITION & INTERPRETATION:**

**1.1 Applicability**

All clauses in the General Conditions of Contract [GCC] shall apply to all transactions except as otherwise stated in the Special Conditions of Contract [SCC] and/or BEC-BRC. Furthermore, in the event if there is any conflict between the Principal text of the Agreement and the Appendixes, the Principal text will prevail.

**1.2 Definition & Interpretation**

In the contract (as hereinafter defined) the following words and expressions shall have the meaning hereby assigned to them except where the context otherwise requires:

**1.2.1 COMPANY/OIL/Operator:**

Shall mean Oil India Limited [OIL] a public sector undertaking, incorporated under COMPANY's Act 1956 having its registered office at Duliajan-786602, Assam, India and includes its successor and permitted assigns.

**1.2.2 CONTRACTOR:**

Shall mean the person or persons, firm or COMPANY or corporation incorporated in India or abroad, who has been awarded with the contract and includes contractor's legal representatives, his successors and permitted assigns.

**1.2.3 Contract:**

Shall mean a written agreement between the COMPANY and the CONTRACTOR for execution of the services/works including all contract documents and subsequent

amendments, if any.

**1.2.4 Site:**

Shall mean the place in which the operations/services are to be carried out or places approved by OIL for the purposes of the CONTRACT together with any other places designated in the CONTRACT as forming part of the site.

**1.2.5 COMPANY's Site Representative/Engineer:**

Shall mean the person or the persons appointed by the COMPANY from time to time to act on its behalf at the site for overall co- ordination, supervision and project management at site.

**1.2.6 Sub-Contract:**

Shall mean order/ contract placed by the CONTRACTOR for any portion of the CONTRACT or work sublet with necessary written consent of COMPANY on third party. Such sub-letting shall not relieve the CONTRACTOR from any obligation, duty or responsibility under the CONTRACT.

**1.2.7 Sub-Contractor:**

Shall mean any person or firm or COMPANY (other than CONTRACTOR) to whom any part of the work has been entrusted by CONTRACTOR, with written consent of OIL or the persons appointed by OIL, successors and permitted assigns of such persons, firm or COMPANY.

**1.2.8 Contractor's Representative:**

Shall mean such person/or persons duly appointed representative at the site and base as the CONTRACTOR may designate in writing to the COMPANY as having authority to act for the CONTRACTOR in matters affecting the work and to provide the requisite services.

**1.2.9 Contract Price/Value:**

Shall mean the sum accepted or the sum calculated in accordance with the rates accepted in tender and/or the contract rates as payable to the CONTRACTOR for the entire execution and completion of the services/works, including amendments/modification/change order issued by the COMPANY.

**1.2.10 Firm price:**

The prices will remain unchanged, except for statutory changes, during currency of the CONTRACT unless specifically agreed to in writing by COMPANY.

**1.2.11 Service/Works/Operations:**

Shall mean and include all items and things to be supplied/done and all work /Service to be performed by the CONTRACTOR as specified in the Scope of Work under this CONTRACT and shall also include all extra, additional, altered or substituted works/services as required for the purpose of successful execution of the Contract.

**1.2.12 Equipment/Materials/Goods :**

Shall mean and include any equipment, machinery, instruments, stores, goods which CONTRACTOR is required to provide to the COMPANY for/under the CONTRACT and amendments thereto.

**1.2.13 Drawings:**

Shall mean and include all Engineering sketches, general arrangements/ layout drawings, sectional plans, all elevations, photographs, etc. related to the CONTRACT together with modification and revision thereto.

**1.2.14 Specifications:**

Means and includes all technical specifications, provision attached and referred to in the tender/contract document regarding method and manner of performing the services and qualities of the service/materials to be provided under the contract and also as modified by the COMPANY/its site representative during the execution of contract in the best interest of service.

**1.2.15 Engineer In-charge (EIC):**

Shall mean the person designated from time to time by the COMPANY and shall include those who are expressly authorized by the COMPANY to act for and on its behalf for operation of the contract.

**1.2.16 Inspectors:**

Shall mean any person or outside Agency nominated by COMPANY to inspect equipment, materials and services, if any, in the CONTRACT (stage wise as well as final) as per the terms of the CONTRACT.

**1.2.17 Tests:**

Shall mean such process or processes to be carried out by the CONTRACTOR as are prescribed in the CONTRACT, considered necessary by the COMPANY or their representative to ascertain quality, workmanship, performance and efficiency of equipment or services thereof.

**1.2.18 Approval:**

Shall mean and include the written consent duly signed by COMPANY or their authorized official in respect of all documents, drawings or other particulars in relation to the CONTRACT.

**1.2.19 Day:**

Shall mean a calendar day of twenty –four (24) consecutive hours beginning at 00:00 hours with reference to local time at the site.

**1.2.20 Month:**

Shall mean a calendar month as per Gregorian calendar.

**1.2.21 Year:**

Shall mean calendar year as per Gregorian calendar.

**1.2.22 Working day:**

Means any day which is not declared to be holiday by the COMPANY.

**1.2.23 Bid/offer:**

Shall mean the proposal/Offer along with supporting documents submitted by the bidder in response to the tender or enquiry in accordance with the terms of Tender or Enquiry, for consideration by COMPANY, prior to award of contract.

**1.2.24 Guarantee:**

Shall mean the period and other conditions governing the warranty/guarantee of the services as provided in the CONTRACT.

**1.2.25 Mobilization:**

Shall mean rendering the equipment fully manned and equipped as per CONTRACT and ready to begin work at site designated by the COMPANY and accepted by the COMPANY after inspection.

**1.2.26 De-mobilization:**

Shall mean the removal of all items forming part of the Mobilization from the site of the COMPANY and inspection and acceptance thereafter by the COMPANY including compliance of requirement in relation to re-export of imported equipment/materials under concessional duty scheme in accordance with relevant notification from Customs Authorities.

**1.2.27 Willful Misconduct:**

Shall mean intentional disregard of good and prudent standards of performance or proper conduct under the Contract with knowledge that it is likely to result in any injury to any person or persons or loss or damage of property of the Company or Third Party.

**1.2.28 Gross Negligence:**

Shall mean any act or failure to act (whether sole, joint or concurrent) by a person or entity which was intended to cause, or which was in reckless disregard of or unjustifiable indifference to, avoidable and harmful consequences such person or entity knew, or should have known, would result from such act or failure to act. Notwithstanding the foregoing, Gross negligence shall not include any action taken in good faith for the safeguard of life or property.

**1.2.29 Criminal Negligence:**

## **E-TENDER: CGI7847P25**

Shall mean that the crime happened negligently, there was duty of care upon the Person but inadvertently due to his negligence, the duty was breached, which causes harm to the people in the form of death or serious injury.

### **1.2.30 GST Legislations:**

‘GST legislations’ means ‘any or all of the following legislations as may be applicable to the CONTRACTOR and OIL:

- (A) The Central Goods & Services Tax Act, 2017;
- (B) The Integrated Goods & Services Act, 2017;
- (C) The Union Territory Goods & Services Tax Act, 2017;
- (D) The respective State Goods & Service Tax Acts’
- (E) The Goods and Services (Compensation to States) Act, 2017
- (F) The Customs Act and the Customs Tariff Act.
- (G) Any other applicable Act related to GST

## **2.0 CONTRACT DOCUMENT:**

**2.1 Governing language:** The governing language for the CONTRACT shall be English. All CONTRACT documents and all correspondence and communication to be given and all other documentation to be prepared and supplied under the CONTRACT shall be written in English and the CONTRACT shall be construed and interpreted in accordance with English language.

**2.2 Entire Agreement:** The CONTRACT constitutes the entire agreement between OIL and the CONTRACTOR with respect to the subject matter of the CONTRACT and supersedes all communication, negotiations and agreement (whether written or oral) of the parties with respect thereto made prior to the date of this agreement, unless such communication(s) expressly forms part of the contract or included by reference.

**2.3 Amendment in CONTRACT:** No Amendment of the Contract shall be valid unless it is in writing, is dated, expressly refers to the Contract, and is signed by a duly authorized representative of each party thereto. OIL shall not be bound by any printed conditions, provisions in the CONTRACTOR’s BID, forms of acknowledgement of CONTRACT, invoice and other documents which purport to impose any condition at variance with or supplement to CONTRACT.

## **3.0 WAIVERS AND AMENDMENTS:**

**3.1 Waivers:** It is fully understood and agreed that none of the terms and conditions of this contract shall be deemed waived by either party unless such waiver is executed in writing only by the duly authorized representatives of both the parties. The failure of either party to execute any right shall not act as a waiver of such right by such

party.

**3.2 Change Program:** It is agreed that CONTRACTOR shall carry out work in accordance with the completion program (e.g. Drilling programme) to be furnished by the COMPANY, which may be changed from time to time by reasonable modifications in the program as COMPANY sees fit. COMPANY's instruction in this regard shall be final and binding.

**4.0 CONTRACT TIMELINE:**

**4.1 Effective Date of Contract:** The contract shall become effective as of the date COMPANY notifies the CONTRACTOR in writing that it has been awarded the contract. This date of issuance of Letter of Award (LOA) by the COMPANY will be the Effective Date of Contract. All terms and conditions of the contract shall come into force with the date of issuance of LOA.

**4.2 Date of Commencement of Operation:**

The date on which the mobilization is completed in all respects and CONTRACTOR is ready to commence operation as per the contract provision [Certified by the COMPANY's representative] will be treated as the date of Commencement of Operation.

**4.3 Duration of the contract:**

The contract shall be valid for a period as defined in the LOA and Special Conditions of Contract [SCC].

**5.0 SCOPE OF WORK/CONTRACT:**

Scope of the CONTRACT shall be as defined in the CONTRACT, specifications, drawings and Appendices.

**6.0 GENERAL OBLIGATION OF CONTRACTOR:**

CONTRACTOR shall, in accordance with and subject to the terms and conditions of this Contract:

**6.1** Perform the work described in the Terms of Reference/Scope of Work. The CONTRACTOR shall execute the work with professional competence and in an efficient and workman like manner.

**6.2** Except as otherwise provided in the Terms of Reference and the special Conditions of the contract, employ all labours/personnel as required to perform the work.

**6.3** Perform all other obligations, work and services which are required by the terms of this contract or which reasonably can be implied from such terms as being necessary for the successful and timely completion of the work.

**6.4** Comply with all applicable statutory obligations specified in the contract.

**6.5** CONTRACTOR shall be deemed to have satisfied himself before submitting their bid as

**E-TENDER: CGI7847P25**

to the correctness and sufficiency of its bid for the services required and of the rates and prices quoted, which rates and prices shall, except insofar as otherwise provided, cover all its obligations under the contract.

**6.6** CONTRACTOR shall be deemed, prior to submitting their bids, to have satisfied themselves about the weather conditions, working culture in the area, socio-political environment, safety & security aspects, law & order situation and law of the land, and obtain for themselves all necessary information as to the risks, contingencies and all other circumstances, which may influence or affect the various obligations under the Contract.

**6.7** CONTRACTOR shall give or provide all necessary supervision during the performance of the services and as long thereafter within the warranty period as COMPANY may consider necessary for the proper fulfilling of CONTRACTOR's obligations under the contract.

**7.0 GENERAL OBLIGATION OF COMPANY:**

COMPANY shall, in accordance with and subject to the terms and conditions of this contract:

**7.1** Pay CONTRACTOR in accordance with terms and conditions of the contract.

**7.2** Allow CONTRACTOR access, subject to normal security and safety procedures, to all areas as required for orderly performance of the work as specified in the Scope of Works of the contract or work connected therewith.

**7.3** Perform all other obligations required of COMPANY by the terms of this contract.

**8.0 DUTIES AND POWER /AUTHORITY:**

**8.1 OIL's site representative/engineer:**

The duties and authorities of OIL's site representative/engineer are to act on behalf of OIL for:

- i. Overall supervision, co-ordination and Project Management at site
- ii. Proper and optimum utilization of equipment and services.
- iii. Monitoring of performance and progress
- iv. Commenting/ countersigning on reports made by the CONTRACTOR's representative at site in respect of works, receipts, consumption etc. after satisfying himself with the facts of the respective cases.
- v. He shall have the authority, but not obligation at all times and any time to

**E-TENDER: CGI7847P25**

inspect/test/examine/ verify any equipment machinery, instruments, tools, materials, personnel, procedures and reports etc. directly or indirectly pertaining to the execution of the work. However this shall not construe to imply an acceptance by the inspector.

Hence, the overall responsibility of quality of work shall rest solely with the CONTRACTOR.

- vi. Each and every document emerging from site in support of any claim by the CONTRACTOR has to have the countersignature/ comments of the OIL's representative/engineer without which no claim shall be entertained by the OIL.

**8.2 CONTRACTOR's representative:**

- (a) The CONTRACTOR's representative shall have all the powers requisite for the performance of the Service/Works, subject to holding due authorisation from the CONTRACTOR.
- (b) Representative(s) shall liaise with OIL's representative/engineer for the proper co-ordination and timely completion of the works and on any matter pertaining to the works.
- (c) Representative(s) shall extend full co-operation to OIL's representative/inspector/engineer in the manner required by them for supervision/inspection/observation of equipment, material, procedures, performance, reports and records pertaining to works.
- (d) To have complete charge of CONTRACTOR's personnel engaged in the performance of the work and to ensure compliance of rules and regulations and safety practice.

**9.0 Personnel to be deployed by contractor:**

CONTRACTOR warrants that it shall provide competent, qualified and sufficiently experienced personnel to perform the work correctly and efficiently.

- 9.1 The CONTRACTOR should ensure that their personnel observe all statutory safety requirement including those prescribed by the COMPANY. Upon COMPANY's written request, CONTRACTOR, entirely at its own expense, shall remove immediately any personnel of the CONTRACTOR determined by the COMPANY to be unsuitable and shall promptly replace such personnel with personnel acceptable to the COMPANY. Replacement personnel should be mobilized within 15 days from the date of issuance of notice without affecting the operation of the COMPANY.

- 9.2 The CONTRACTOR shall be solely responsible throughout the period of the contract for providing all requirements of their personnel including but not limited to, their transportation to & fro from Duliajan/field site, enroute/ local boarding, lodging, personal protective gear & medical attention etc. COMPANY shall have no responsibility or liability in this regard.

- 9.3 However, COMPANY shall provide available medical assistance/facilities to

**E-TENDER: CGI7847P25**

CONTRACTOR's Personnel in case of emergency at its own establishment on chargeable basis.

- 9.4 CONTRACTOR's key personnel shall be fluent in English language (both writing and speaking).

**10.0 PERFORMANCE SECURITY:**

- 10.1 On receipt of notification of award from the COMPANY, the CONTRACTOR shall furnish the Performance Security to COMPANY within **30 (Thirty)** days from the date of issue of LOA for an amount specified in the Forwarding Letter and Letter of Award (LOA) as per Proforma-Form and must be in the form of an Insurance Surety Bond/Bank Draft/ Cashier's cheque/Banker's cheque\*/NEFT/RTGS/Electronic fund transfer to designated account of OIL# or Fixed Deposit Receipt (account OIL INDIA LIMITED) or irrevocable Bank Guarantee or irrevocable Letter of Credit (LC) from:

- a. Any schedule Indian Bank or Any Branch of an International bank situated in India and registered with Reserve Bank of India as scheduled foreign bank in case of domestic CONTRACTOR/service provider.

OR

- b. Any scheduled bank in India or from International bank who has its branch in India registered with Reserve Bank of India, in case of foreign CONTRACTOR/service provider.

OR

- c. Any foreign Bank which is not a Scheduled Bank in India, provided the Bank Guarantee issued by such Bank is counter-guaranteed by any Branch situated in

India of any Scheduled Bank incorporated in India.

Note: Bank Guarantee issued by a Scheduled Bank of India at the request of some other Non-Schedule Bank of India shall not be acceptable.

- 10.2 Bank Guarantee issued by a Bank, amongst others, must contain the following particulars of such bank:

Full address Branch Code

Code Nos. of the authorized signatory with full name and designation. Phone Nos.

Fax Nos.

E-mail address.

- 10.3 The domestic CONTRACTOR/service provider(s) will have to submit the Bank Guarantee from any of the scheduled banks and on non- judicial stamp paper of requisite value as per the Indian Stamp Act, purchased in the name of the issuing banker.

- 10.4 The foreign CONTRACTOR/service provider(s) will submit the Bank Guarantee from Banks of Indian origin situated in their country. In case no such bank of Indian origin is situated in their country, the Bank Guarantee may be submitted from the bankers as specified above.

## **E-TENDER: CGI7847P25**

- 10.5** The Performance Security shall be denominated in the currency of the contract.
- 10.6** The Performance Security specified above must be valid for the entire duration of the Contract and claim period should be valid for a minimum of 03 (three) months beyond the contract period. The Performance Security will be discharged by COMPANY not later than 30 days following its expiry of claim period. In the event of any extension of the Contract period, Bank Guarantee should be extended by CONTRACTOR by the period equivalent to the extended period.
- 10.7** The Performance Security shall be encashed by COMPANY on account of CONTRACTOR's failure to fulfil its obligations under the Contract and/or non-performance/un-satisfactory performance of the Contractor. Company shall not be required to proof any loss or damage on account of Contractor's non-performance/un-satisfactory performance.
- 10.8** The Performance Security will not accrue any interest during its period of validity or extended validity.
- 10.9** Failure of the successful Bidder to comply with the requirements of clause [10.0](#) shall constitute sufficient grounds for annulment of the award. In such an eventuality, action will be initiated as per the Banning Policy of OIL in vogue.

# Subject to credit in OIL's account within prescribed time

\* The validity of Bank Draft/Cashier's/Banker's cheque (as applicable) should not be less than 3 months.

In the event CONTRACTOR fails to honour any of the commitments entered into under this agreement, and /or in the event of termination of the contract under provisions of Integrity Pact and /or in respect of any amount due from the CONTRACTOR to OIL, OIL shall have unconditional option under the guarantee to invoke the above bank guarantee and claim the amount from the bank. The bank shall be obliged to pay the amount to OIL on demand.

### **11.0 SIGNING OF CONTRACT:**

- 11.1** The successful bidder is required to sign a formal detailed contract with OIL within a maximum period of 60 days of date of LOA. Until the contract is signed, the LOA **as well as GCC & SCC as prescribed in the Tender**, shall remain binding amongst the two parties. In the event of failure on the part of the successful Bidder to sign the contract, OIL reserves the right to terminate the LOA issued to the successful Bidder and invoke the Performance Security if submitted by the successful Bidder. Such CONTRACTOR shall be put on holiday as per the Banning Policy of OIL [available at [www.oil-india.in](http://www.oil-india.in)].

### **12.0 CLAIMS, TAXES & DUTIES:**

- 12.1 **Claims:**** CONTRACTOR agrees to pay all claims, taxes and fees for equipment, labour, materials, services and supplies to be furnished by it hereunder and agrees to allow

**E-TENDER: CGI7847P25**

no lien or charge resulting from such claims to be fixed upon any property of COMPANY. COMPANY may, at its option, pay and discharge any liens or overdue charges for CONTRACTOR's equipment, labour, materials, services and supplies under this CONTRACT and may thereupon deduct the amount or amounts so paid from any sum due, or thereafter become due, to CONTRACTOR hereunder.

**12.2 Notice of claims:** CONTRACTOR or COMPANY, as the case may be, shall promptly give the other, notice in writing of any claim made or proceeding commenced for which that party is entitled to indemnification under the CONTRACT. Each party shall confer with the other concerning the defense of any such claims or proceeding, shall permit the other to be represented by counsel in defense thereof, and shall not affect settlement of or compromise any such claim or proceeding without the other's written consent.

**12.3 Taxes:**

**12.3.1** CONTRACTOR, unless specified otherwise in the CONTRACT, shall bear all tax liabilities, duties, Govt. levies etc. including GST and customs duty, Corporate and personnel taxes levied or imposed on the CONTRACTOR on account of payments received by it from the COMPANY for the work done under this CONTRACT. It shall be the responsibility of CONTRACTOR to submit to the concerned Indian authorities, the returns and all other concerned documents required for this purpose and to comply in all respects with the requirements of the laws in this regard, in time.

**12.3.2** Tax levied on CONTRACTOR as per the provisions of Indian Income Tax Act and any other enactment/rules on income derived/payments received under the contract will be on CONTRACTOR's account.

**12.3.3** CONTRACTOR shall be responsible for payment of personal taxes, if any, for all the personnel deployed in India by CONTRACTOR.

**12.3.4** The CONTRACTOR shall furnish to the COMPANY, if and when called upon to do so, relevant statement of accounts or any other information pertaining to work done under the contract for submitting the same to the Tax authorities, on specific request from them in accordance with provisions under the law. CONTRACTOR shall be responsible for preparing and filing the return of income etc. within the prescribed time limit to the appropriate authority.

**12.3.5** Prior to start of operations under the contract, the CONTRACTOR shall furnish the COMPANY with the necessary documents, as asked for by the COMPANY and/ or any other information pertaining to the contract, which may be required to be submitted to the Income Tax authorities at the time of obtaining "No Objection Certificate" for releasing payments to the CONTRACTOR.

**12.3.6** Corporate income tax will be deducted at source from the invoice at the specified rate of income tax as per the provisions of Indian Income Tax Act as may be in force from time to time and COMPANY will issue TDS Certificate to the CONTRACTOR as per the provisions of Income Tax Act.

**E-TENDER: CGI7847P25**

- 12.3.7** Corporate and personnel taxes on CONTRACTOR shall be the liability of the CONTRACTOR and the COMPANY shall not assume any responsibility on this account.
- 12.3.8** All local taxes, levies and duties, sales tax, octroi, etc. on purchases and sales made by CONTRACTOR shall be borne by the CONTRACTOR.
- 12.3.9** CONTRACTOR shall provide all the necessary compliances/ invoice/documents for enabling OIL to avail Input tax credit benefits in respect of the payments of GST which are payable against the CONTRACT. The CONTRACTOR should provide tax invoice issued under GST legislations for the goods and Services (indicating GST). Payment towards the components of GST shall be released by OIL only against appropriate documents i.e.: Tax Invoice/Bill of entry for availing input tax credit (as applicable).
- 12.3.10** The tax invoices as per above provisions should contain all the particulars as required under the invoicing rules under the GST legislations, including, but not limited to the following:
- i. Name, Address and the GST Registration Number (under the relevant Tax Rules) of the Service Provider (CONTRACTOR)
  - ii. Name and Address and GST Registration Number of the Service Receiver (Address of OIL)
  - iii. Description, Classification and Value of taxable service/goods and the amount of applicable tax (CGST, SGST, IGST, UTGST and cess)
- 12.3.11** In case of imported goods, CONTRACTOR/supplier is required to provide original Bill of Entry or copy of Bill of Entry duly attested by Custom authority.
- 12.3.12** The CONTRACTOR should mention the Place of supply in the invoice raised under GST Law.
- 12.3.13** OIL would not accept any invoice without its GSTIN mentioned on the invoice

*Note: CONTRACTOR who is under composition levy of the GST legislation would raise Bill of supply instead of Tax invoice, which will have GSTIN of supplier as well as OIL.*

**12.4 Goods and Services Tax:**

- 12.4.1** "GST" shall mean Goods and Services Tax charged on the supply of material(s) and services. The term "GST" shall be construed to include the Integrated Goods and Services Tax (hereinafter referred to as "IGST") or Central Goods and Services Tax (hereinafter referred to as "CGST") or State Goods and Services Tax (hereinafter referred to as "SGST") or Union Territory Goods and Services Tax (hereinafter referred to as "UTGST") depending upon the import/interstate or intrastate supplies, as the case may be. It shall also mean GST compensation Cess, if applicable.
- 12.4.2** Where the OIL is entitled to avail the input tax credit of GST:

## **E-TENDER: CGI7847P25**

OIL will reimburse the GST to the Supplier of Goods/Services (Service Provider) at actual against submission of Invoices as per format specified in rules/ regulation of GST to enable OIL to claim input tax credit of GST paid. In case of any variation in the executed quantities, the amount on which the GST is applicable shall be modified in same proportion. Returns and details required to be filled under GST laws & rules should be timely filed by supplier with requisite details.

### **12.4.3** Where the OIL is not entitled to avail/take the full input tax credit of GST:

OIL will reimburse GST to the Supplier of Goods/Services (Service Provider) at actual against submission of Invoices as per format specified in rules/ regulation of GST subject to the ceiling amount of GST as quoted by the bidder. In case of any variation in the executed quantities (If directed and/or certified by the In-Charge) the ceiling amount on which GST is applicable will be modified on pro-rata basis.

### **12.4.4** The CONTRACTOR will be under obligation for charging correct rate of tax as prescribed under the respective tax laws. Further the CONTRACTOR shall avail and pass on benefits of all exemptions/concessions available under tax laws. Any error of interpretation of applicability of taxes/ duties by the CONTRACTOR shall be to CONTRACTOR's account.

### **12.4.5** In case of statutory variation in GST, other than due to change in turnover, payable on the contract value during contract period, the Supplier of Goods/ Services (Service Provider) shall submit a copy of the 'Government Notification' to evidence the rate as applicable on the Bid due date and on the date of revision.

### **12.4.6** Beyond the contract period, in case OIL is not entitled for input tax credit of GST, then any increase in the rate of GST beyond the contractual delivery period shall be to Service provider's account whereas any decrease in the rate GST shall be passed on to the OIL.

### **12.4.7** Beyond the contract period, in case OIL is entitled for input tax credit of GST, then statutory variation in applicable GST on supply and on incidental services, shall be to OIL's account.

### **12.4.8** Claim for payment of GST/ Statutory variation, should be raised within two [02] months from the date of issue of 'Government Notification' for payment of differential (in %) GST, otherwise claim in respect of above shall not be entertained for payment of arrears.

### **12.4.9** The base date for the purpose of applying statutory variation shall be the Bid Opening Date.

### **12.4.10** The CONTRACTOR will be liable to ensure to have registered with the respective tax authorities, wherever applicable and to submit self- attested copy of such registration certificate(s) and the CONTRACTOR will be responsible for procurement of material in its own registration (GSTIN) and also to issue its own Road Permit/ E-way Bill, if applicable etc.

## **12.5 Anti-profiteering clause**

## **E-TENDER: CGI7847P25**

**12.5.1** As per Clause 171 of GST Act it is mandatory to pass on the benefit due to reduction in rate of tax or from input tax credit to the consumer by way of commensurate reduction in prices.

**12.5.2** In case rating of Contractor is negative/black listed after award of work for supply of goods/services, then OIL shall not be obligated or liable to pay or reimburse GST to such vendor/Contractor and shall also be entitled to deduct/recover such GST along with all penalties/interest, if any, incurred by OIL.

### **13.0 CUSTOMS DUTY, IF APPLICABLE:**

**13.1.1** CONTRACTOR shall be responsible to import the equipment/tools/spares/consumables etc. required for execution of the contract. The CONTRACTOR shall undertake to complete all the formalities as required under the Customs Act/Foreign Trade Policy (FTP) and indemnify OIL from all the liabilities of Customs in this regard.

**13.1.2** CONTRACTOR will be solely responsible for payment of all applicable Customs Duty and to comply all Rules and Regulations. Total Contract Price/Value is inclusive of all Customs Duty, if not mentioned otherwise elsewhere in the Contract.

**13.1.3** Above clause is to be read with Customs Duty Clause in SCC, if any.

### **14.0 INSURANCE:**

**14.1** The Contractor shall at its own expense arrange secure and maintain insurance with reputed insurance companies to the satisfaction of the Company as follows:

- a) The Contractor shall, at his own expense, arrange appropriate comprehensive insurance (All-risks insurance cover with suitable limit as per International Standard) to cover all risks assumed by the Contractor under this Contract in respect of its equipment, tools including but not limited to well equipment & tools, any other belongings and personnel during the entire period of this Contract including extensions thereof.
- b) The Contractor shall also carry adequate insurance cover against damage/loss to third party/person/property.
- c) The Contractor at his cost shall arrange, secure and maintain insurance as may be necessary and to its full value for all such amounts to protect the works-in-progress from time to time and the interest of Company against all risks as detailed herein subject to the satisfaction of the Company and irrespective of acceptance of the Work.
- d) The responsibility to maintain adequate insurance coverage at all times during the period of the Contract shall be that of the Contractor alone and OIL will have no liability on this account. The Contractor's failure in this regard shall not relieve him

**E-TENDER: CGI7847P25**

of any of his responsibilities & obligations under the Contract.

- e) All costs on account of insurance liabilities covered under the Contract will be to the Contractor's account.

**14.2 Deductible:**

The Contractor shall take policy with minimum deductible as per IRDA prescribed for the policy(ies) that portion of any loss not covered by the insurance provided for in this article solely by reason of a deductible provision in such insurance policies that shall be the account of the Contractor.

- 14.3** The Contractor shall require all of its sub-Contractor to provide such of the foregoing insurance coverage as Contractor is obliged to provide under this Contract and inform the Company about the coverage prior to the commencement of agreements with its sub-Contractors.

- 14.4** All insurance taken out by Contractor or their sub-contractor shall be endorsed to provide that the underwriters waive their rights of recourse on the Company and to the extent of the liabilities assumed by Contractor under this Contract.

**14.5 Waiver of subrogation:**

All insurance policies of the Contractor and its Sub-Contractor with respect to the operations conducted hereunder as set forth in clauses hereof, shall be endorsed by the underwriter in accordance with the following policy wording:

"The insurers hereby waive their rights of subrogation against Oil India Limited or any of their employees or their affiliates and assignees."

**14.6 Loss Payee Clause:**

The Insurance Policies should mention the following in Loss Payee Clause:

"In respect of Insurance claims in which OIL's interest is involved, written consent of OIL will be required".

**14.7 Additional Assured:**

"**Oil India Limited**" is to be included as Additional Assured in the Insurance Policies (except in case of Workmen's Compensation/Employer's Liability insurance).

**14.8 Certificate of Insurance:**

Before commencing performance of the CONTRACT, CONTRACTOR shall furnish OIL with certificates of insurance indicating:

- a) Kinds and amounts of insurance as required herein  
b) Details of coverage

**E-TENDER: CGI7847P25**

- c) Insurance corporation or companies carrying the aforesaid coverage
- d) Effective and expiry dates of policies
- e) That OIL shall be given thirty (30) days written advance notice of any material change in the policy
- f) Waiver of subrogation endorsement has been attached to all policies and

**Note: An undertaking by the service provider has to be mandatorily provided during the Mobilisation time that they have taken all the Insurance provisions as per the contract and as the Law and Insurance Regulation.**

**14.9** If any of the above policy expire or/are cancelled during the term of this CONTRACT and CONTRACTOR fails for any reason to renew such policies, OIL in no case shall be liable for any loss/damage occurred during the term when the policy is not effective. Furthermore, a penal interest @ 1% of the Total contract value shall be charged towards not fulfilling of the contractual obligations. Notwithstanding above, should there be a lapse in any insurance required to be taken by the Contractor for any reason whatsoever, loss/damage claims resulting therefrom shall be to the sole account of Contractor.

**14.10** The Contractor on demand from the Company shall furnish the Insurance Policy having detail terms and conditions, with respect to any Certificate of Insurance submitted to the Company.

**14.11 On account payment to OIL in case of claim**

In case any loss or damage happen and where Company's interest is involved, The Company reserves the right to recover the loss amount from the Contractor prior to final settlement of the claim.

**14.12** The CONTRACTOR shall at all time during the currency of the contract provide, pay for and maintain the following insurance amongst others:

- i) **Employees Compensation (EC) Policy or Employer's Liability Policy insurance**  
as required by the laws of the country of origin of the employee.
- ii) **Commercial General Liability Insurance:** Commercial General Public Liability Insurance covering liabilities including contractual liability for bodily injury, including death of persons, and liabilities for damage of property. This insurance must cover all operations of CONTRACTOR required to fulfil the provisions under this Contract.
- iii) **Comprehensive General Automotive Liability:** Automobile Public Liability Insurance covering owned, non-owned and hired automobiles used in the performance of the work hereunder, with bodily injury limits and property damage limits shall be governed by Indian Insurance Regulations.
- iv) **Carrier's Legal Liability Insurance:** Carrier's Legal Liability Insurance in respect of

## **E-TENDER: CGI7847P25**

**all CONTRACTOR's items** to be transported by the CONTRACTOR to the site of work, for physical loss or destruction of or damage to goods or merchandise, while in transit.

- v) **Public Liability Act Policy:** Public Liability Act Policy, if applicable, covering the statutory liability arising out of accidents occurring during the currency of the contract due to handling hazardous substances as provided in the Public Liability Insurance Act 1991 and the Rules framed there under. In case there is no usage of hazardous substance, the Contractor should provide an undertaking during mobilization as per format enclosed regarding non-inclusion of hazardous substances within the ambit of the contract.
- vi) **Pradhan Mantri Suraksha Bima Yojana (PMSBY) and Pradhan Mantri Jeevan Jyoti Bima Yojana (PMJJBY):** CONTRACTOR shall, ensure that all his/its personnel deployed under this contract have obtained additional insurance coverage under the Pradhan Mantri Suraksha Bima Yojana (PMSBY) and Pradhan Mantri Jeevan Jyoti Bima Yojana (PMJJBY) through the participating banks and submit the proof of such insurance coverage to the satisfaction of OIL.

Note: This will be applicable for only Indian citizens and within the prescribed age group defined under the scheme for the insurance coverage.

- vii) **Any other insurance policy set forth in the SCC**

### **15.0 LIABILITY:**

- 15.1** Except as otherwise expressly provided herein, neither COMPANY nor its servants, agents, nominees, CONTRACTORS, or sub- CONTRACTORS shall have any liability or responsibility whatsoever to whomsoever for loss of or damage to the equipment and/or loss of or damage to the property of the CONTRACTOR and/or their CONTRACTORS or sub-CONTRACTORS, irrespective of how such loss or damage is caused and even if caused by the negligence of COMPANY and/or its servants, agent, nominees, assignees, CONTRACTORS and sub-CONTRACTORS.
- 15.2** The CONTRACTOR shall protect, defend, indemnify and hold harmless COMPANY from and against such loss or damage and any suit, claim or expense resulting there from. Neither COMPANY nor its servants, agents, nominees, assignees, CONTRACTORS, sub-CONTRACTORS shall have any liability or responsibility whatsoever for injury to, illness, or death of any employee of the CONTRACTOR and/or of its CONTRACTORS or sub-CONTRACTOR irrespective of how such injury, illness or death is caused and even if caused by the negligence of COMPANY and/or its servants, agents nominees, assignees, CONTRACTORS and sub-CONTRACTORS. CONTRACTOR shall protect, defend, indemnify and hold harmless COMPANY from and against such liabilities and any suit, claim or expense resulting there from.
- 15.3** The CONTRACTOR hereby agrees to waive its right of recourse and further agrees to cause its underwriters to waive their right of subrogation against COMPANY and/or its underwriters, servants, agents, nominees, assignees, CONTRACTORS and sub-CONTRACTORS for loss or damage to the equipment of the CONTRACTOR and/or its

**E-TENDER: CGI7847P25**

sub-CONTRACTORS and/or their employees when such loss or damage or liabilities arises out of or in connection with the performance of the contract limited to the CONTRACTOR's liabilities agreed to under this Contract.

- 15.4** The CONTRACTOR hereby further agrees to waive its right of recourse and agrees to cause its underwriters to waive their right of subrogation against COMPANY and/or its underwriters, servants, agents, nominees, assignees, CONTRACTORS and sub-CONTRACTORS for injury to, illness or death of any employee of the CONTRACTOR and of its CONTRACTORS, sub-CONTRACTORS and/or their employees when such injury, illness or death arises out of or in connection with the performance of the contract limited to the CONTRACTOR's liabilities agreed to under this Contract.
- 15.5** Except as otherwise expressly provided herein, neither CONTRACTOR nor its servants, agents, nominees, CONTRACTORS or sub- CONTRACTORS shall have any liability or responsibility whatsoever to whomsoever for loss of or damage to the equipment and/or loss or damage to the property of the COMPANY and/or their CONTRACTORS or sub-CONTRACTORS, irrespective of how such loss or damage is caused and even if caused by the negligence of CONTRACTOR and/or its servants, agents, nominees, assignees, CONTRACTORS and sub- CONTRACTORS. The COMPANY shall protect, defend, indemnify and hold harmless CONTRACTOR from and against such loss or damage and any suit, claim or expense resulting there from.
- 15.6** Except as otherwise expressly provided herein, neither CONTRACTOR nor its servants, agents, nominees, assignees, CONTRACTORS, sub- CONTRACTORS shall have any liability or responsibility whatsoever to whomsoever for injury or illness, or death of any employee of the COMPANY and/or of its CONTRACTORS or sub- CONTRACTORS irrespective of how such injury, illness or death is caused and even if caused by the negligence of CONTRACTOR and/or its servants, agents, nominees, assignees, CONTRACTORS and sub- CONTRACTORS. COMPANY shall protect, defend indemnify and hold harmless CONTRACTOR from and against such liabilities and any suit, claim or expense resulting there from.
- 15.7** The COMPANY agrees to waive its right of recourse and further agrees to cause its underwriters to waive their right of subrogation against CONTRACTOR and/or its underwriters, servants, agents, nominees, assignees, CONTRACTORS and sub-CONTRACTORS for loss or damage to the equipment of COMPANY and/or its CONTRACTORS or sub-CONTRACTORS when such loss or damage or liabilities arises out of or in connection with the performance of the contract.
- 15.8** The COMPANY hereby further agrees to waive its right of recourse and agrees to cause it underwriters to waive their right of subrogation against CONTRACTOR and/or its underwriters, servants, agents, nominees, assignees, CONTRACTORS and sub-CONTRACTORS for injury to, illness or death of any employee of the COMPANY and of its CONTRACTORS, sub-CONTRACTORS and/or their employees when such injury, illness or death arises out of or in connection with the performance of the Contract.

**16.0 LIMITATION OF LIABILITY:**

**E-TENDER: CGI7847P25**

- a) Notwithstanding any other provisions herein to the contrary, except only in cases of Wilful misconduct and/or criminal acts and/or criminal negligence, neither the CONTRACTOR nor the COMPANY (OIL) shall be liable to the other, whether in Contract, tort, or otherwise, for any consequential loss or damage, loss of use, loss of production, or loss of profits or interest costs, provided however that this exclusion shall not apply to any obligation of the CONTRACTOR to pay Liquidated Damages to the COMPANY and/or COMPANY's right to forfeit the Performance Bank Guarantee(s) in terms of the contract.
- b) Notwithstanding any other provisions incorporated elsewhere in the contract, the aggregate liability of the CONTRACTOR in respect of this contract, whether under Contract, in tort or otherwise, shall not exceed 100% of the Contract Price (if not specified otherwise in SCC), provided however that this limitation shall not apply to the cost of repairing or replacing defective equipment by the CONTRACTOR, or to any obligation of the CONTRACTOR to indemnify the COMPANY with respect to Intellectual Property Rights.
- c) COMPANY shall indemnify and keep indemnified CONTRACTOR harmless from and against any and all claims, costs, losses and liabilities in excess of the aggregate liability amount in terms of clause (b) above.

**17.0 LIABILITY OF UNION GOVERNMENT OF INDIA:**

It is expressly understood and agreed upon by and between CONTRACTOR and OIL INDIA LIMITED, and that OIL INDIA LIMITED is entering into this agreement solely on its own behalf and not on behalf of any other person or entity. In particular, it is expressly understood and agreed that Union of India is not a party to this agreement and has no liabilities, obligations or rights, whatsoever hereunder. It is expressly understood and agreed that OIL INDIA LIMITED is an independent legal entity with power and authority to enter into contracts solely on its own behalf under the applicable laws of India and general principles of the Contract law. The bidder/ CONTRACTOR expressly agrees, acknowledges and understands that OIL INDIA LIMITED is not an agent, representative or delegate of the Union of India. It is further understood and agreed that Union of India is not and shall not be liable for any acts, omissions, commissions, breaches or other wrongs arising out of the contract. Accordingly, bidder/ CONTRACTOR hereby expressly waives, releases and foregoes any and all actions or claims, including cross claims, impleader claims or counter claims against the Union of India arising out of this contract and covenants not to sue the Union of India as to any manner, claim, cause of action or thing whatsoever arising of or under this agreement.

**18.0 CONSEQUENTIAL DAMAGE:**

Except as otherwise expressly provided, neither party shall be liable to the other for special, indirect or consequential damages resulting from or arising out of the contract, including but without limitation, to loss or profit or business interruptions, howsoever caused and regardless of whether such loss or damage was caused by the negligence (either sole or concurrent) of either party, its employees, agents or sub-CONTRACTORS.

**19.0 RISK PURCHASE:**

In the event, CONTRACTOR's failure to provide the services as per the Contractual

**E-TENDER: CGI7847P25**

scope, terms and conditions, COMPANY (OIL) reserves the right to hire the services from any other source at the CONTRACTOR's risk & cost and the difference in cost shall be borne by the CONTRACTOR. Further, OIL shall retain the right of forfeiture of Performance Bank Guarantee and any other action as deemed fit. In certain operational situations OIL reserves the right to take over the site including the service equipment at the risk and cost of the CONTRACTOR.

**20.0 INDEMNITY AGREEMENT:**

**20.1** Except as provided hereof CONTRACTOR agrees to protect, defend, indemnify and hold COMPANY harmless from and against all claims, suits, demands and causes of action, liabilities, expenses, cost, liens and judgments of every kind and character, without limit, which may arise in favour of CONTRACTOR's employees, agents, CONTRACTORS and sub-CONTRACTORS or their employees or in favour of any third party(is) on account of bodily injury or death, or damage to personnel/property as a result of the operations contemplated hereby, regardless of whether or not said claims, demands or causes of action arise out of the negligence or otherwise, in whole or in part or other faults.

**20.2** Except as provided hereof COMPANY agrees to protect, defend, indemnify and hold CONTRACTOR harmless from and against all claims, suits, demands and causes of action, liabilities, expenses, cost, liens and judgments of every kind and character, without limit, which may arise in favour of COMPANY's employees, agents, CONTRACTORS and sub-CONTRACTORS or their employees or in favour of any third party(is) on account of bodily injury or death, or damage to personnel/property as a result of the operations contemplated hereby, regardless of whether or not said claims, demands or causes of action arise out of the negligence or otherwise, in whole or in part or other faults.

**21.0 INDEMNITY APPLICATION:**

The indemnities given herein above, whether given by COMPANY or CONTRACTOR shall be without regard to fault or to the negligence of either party even though said loss, damage, liability, claim, demand, expense, cost or cause of action may be caused, occasioned by or contributed to by the negligence, either sole or concurrent of either party.

**22.0 ROYALTY PATENTS:**

Each party shall hold harmless and indemnify the other from and against all claim and proceedings for or on account of any patent rights, design, trade mark or other protected rights arising from any use of materials, equipment, processes, inventions and methods, which have not been imposed on the attending party by the terms of the contract or the specifications forming part thereof.

**23.0 WARRANTY AND REMEDY OF DEFECTS:**

**23.1** CONTRACTOR warrants that they shall perform the work in a first class, workmanlike, and professional manner and in accordance with their highest degree of quality, efficiency and current state of the art technology/industry practices and in conformity with all specifications, standards and drawings set forth or referred to in the Terms

## **E-TENDER: CGI7847P25**

of Reference and with instructions and guidance, which COMPANY may, from time to time, furnish to the CONTRACTOR.

- 23.2** Should COMPANY discover at any time during the tenure of the Contract or till the Unit/equipment/tools are demobilised from site or base camp (if applicable) that the work does not conform to the foregoing warranty, CONTRACTOR shall after receipt of notice from COMPANY, promptly perform any and all corrective work required to make the services conform to the Warranty. Such corrective Work shall be performed entirely at CONTRACTOR's own expenses. If such corrective Work is not performed within a reasonable time, the COMPANY, at its option may have such remedial Work performed by others and charge the cost thereof to CONTRACTOR subject to a maximum of the contract value payable for the defective work which needs corrective action which the CONTRACTOR must pay promptly. In case CONTRACTOR fails to perform remedial work, or pay promptly in respect thereof, the performance security shall be forfeited.

### **24.0 SUBCONTRACTING/ASSIGNMENT:**

- 24.1** CONTRACTOR shall not subcontract, transfer or assign the contract, or any part under this contract, to any third party(ies). Except for the main services under this contract, CONTRACTOR may sub-contract the petty support services subject to COMPANY's prior written approval. However, CONTRACTOR shall be fully responsible for complete execution and performance of the services under the Contract.
- 24.2** Consequent upon of placement of contract, if successful bidder(s)(other than Micro/Small Enterprise) is procuring materials/services from their sub-vendor, who is a Micro or Small Enterprise registered with District Industry Centers or Khadi and Village Industries Commission or Khadi and Village Industries Board or Coir Board or National Small Industries Corporation or Directorate of Handicrafts and Handloom or any other body specified by Ministry of MSME with prior consent in writing of the purchasing authority/Engineer in Charge the details like Name, Registration No., Address, Contact No., details of material and value of procurement made, etc. of such enterprises shall be furnished by the CONTRACTOR at the time of submission of invoice/bill.

### **25.0 RECORDS, REPORTS AND INSPECTION:**

The CONTRACTOR shall, at all times during the currency of the contract, permit the COMPANY and its authorized employees and representatives to inspect all the Work performed and to witness and check all the measurements and tests made in connection with the said work. The CONTRACTOR shall keep an authentic, accurate history and logs including safety records of each service item with major items consumed, which shall be open at all reasonable times for inspection by the COMPANY's designated representatives and its authorized employees. The CONTRACTOR shall provide the COMPANY's designated representatives with a daily written report, on form prescribed by the COMPANY showing details of operations during the preceding 24 hours and any other information related to the said services requested by the COMPANY whenever so requested. The CONTRACTOR shall not, without COMPANY's written consent allow any third person(s) access to the said

**E-TENDER: CGI7847P25**

information or give out to any third person information in connection therewith.

**26.0 CONFIDENTIALITY, USE OF CONTRACT DOCUMENTS AND INFORMATION:**

**26.1** CONTRACTOR shall not, without COMPANY's prior written consent, disclose the contract, or any provision thereof, or any specification, plan, drawing pattern, sample or information furnished by or on behalf of COMPANY in connection therewith, to any person other than a person employed by CONTRACTOR in the performance of the contract. Disclosure to any such employed person shall be made in confidence and shall extend only, as may be necessary for purposes of such performance with prior permission from COMPANY. However, nothing hereinabove contained shall deprive the CONTRACTOR of the right to use or disclose any information which is:

- a) possessed by the CONTRACTOR, as evidenced by the CONTRACTOR's written records, before receipt thereof from the COMPANY which however the CONTRACTOR shall immediately inform to COMPANY ; or
- b) required to be disclosed by the CONTRACTOR pursuant to an order of a court of competent jurisdiction or other governmental agency having the power to order such disclosure, provided the CONTRACTOR uses its best efforts to provide timely notice to COMPANY of such order to permit COMPANY an opportunity to contest such order subject to prior permission from COMPANY.

**26.2** CONTRACTOR shall not, without COMPANY's prior written consent, make use of any document or information except for purposes of performing the contract.

**26.3** Any document supplied to the CONTRACTOR in relation to the contract other than the Contract itself remain the property of COMPANY and shall be returned (in all copies) to COMPANY on completion of CONTRACTOR's performance under the Contract if so required by COMPANY.

**26.4** During the currency of the Contract, COMPANY and its employees, agents, other CONTRACTORS, sub-CONTRACTORS (of any tier) and their employees etc. may be exposed to certain confidential information and data of the CONTRACTOR. Such information and data held by the COMPANY, its employees, agents, other CONTRACTORS, sub-CONTRACTORS (of any tier) and their employees in the strictest Confidence and shall not be disclosed to any other party except on a need to know basis.

However, the above obligation shall not extend to information which:

- i) is, at the time of disclosure, known to the public which CONTRACTOR shall immediately inform COMPANY ;
- ii) is lawfully becomes at a later date known to the public through no fault of CONTRACTOR subject to CONTRACTOR's undertaking that no information has been divulged by them to the public;
- iii) is lawfully possessed by CONTRACTOR before receipt thereof from COMPANY which should be immediately informed to COMPANY;

**E-TENDER: CGI7847P25**

- iv) is developed by CONTRACTOR independently of the information disclosed by COMPANY which should be shared with the COMPANY;
- v) CONTRACTOR is required to produce before competent authorities or by court order subject to prior permission from COMPANY;

**27.0 REMUNERATION AND TERMS OF PAYMENT:**

- 27.1** COMPANY shall pay to the CONTRACTOR during the term of the Contract the amount due from time to time calculated according to the rates of payment set and in accordance with other provisions hereof. No other payments shall be due from COMPANY unless specifically provided for in the Contract. All payments will be made in accordance with the terms hereinafter described.
- 27.2** Request for payment/part payment to third party i.e. other than the party on whom the contract has been awarded will not be entertained by OIL under any circumstances.
- 27.3** MANNER OF PAYMENT: All payments due by COMPANY to CONTRACTOR hereunder shall be made at CONTRACTOR's designated bank. Bank charges, if any will be on account of the CONTRACTOR.
- 27.4** Payment of any invoices shall not prejudice the right of COMPANY to question the validity of any charges therein, provided COMPANY within one year after the date of payment shall make and deliver to CONTRACTOR written notice of objection to any item or items the validity of which COMPANY questions.
- 27.5** INVOICES: Mobilization charges will be invoiced only upon completion of mobilization as certified by COMPANY representative and CONTRACTOR is ready at site for starting the services/ operation. Payment of mobilization charges shall be made within 45 days following the date of receipt of undisputed invoices by COMPANY.
- 27.6** CONTRACTOR shall send invoice to COMPANY on the day following the end of each month for all daily or monthly charges due to the CONTRACTOR.
- 27.7** CONTRACTOR will submit 02 (Two) sets of all invoices duly super scribed 'Original' and 'copy' as applicable to the COMPANY for processing payment. Separate invoices for the charges payable under the contract shall be submitted by the CONTRACTOR for foreign currency and Indian currency.
- 27.8** Payment of monthly invoices, if undisputed, shall be made within 30 days following the date of receipt of invoice by COMPANY.
- 27.9** COMPANY shall within 30 days of receipt of the invoice notify the CONTRACTOR of any item under dispute, specifying the reasons thereof, in which event, payment of the disputed amount may be withheld until settlement of the dispute, but payment shall be made of any undisputed portion on or before the due date. This will not prejudice the COMPANY's right to question the validity of the payment at a later date as envisaged in clause no. **27.4** above.

**E-TENDER: CGI7847P25**

- 27.10** The acceptance by CONTRACTOR of part payment on any billing not paid on or before the due date shall not be deemed a waiver of CONTRACTOR's rights in any other billing, the payment of which may then or thereafter be due.
- 27.11** Payment of Final demobilization charges shall be made if applicable within 45 days on receipt of invoice by COMPANY accompanied by the following documents from the CONTRACTOR:
- a) Audited account up to completion of the Contract.
  - b) Tax audit report for the above period as required under the Indian Tax Laws.
  - c) Documentary evidence regarding the submission of returns and payment to taxes for the expatriate personnel engaged by the CONTRACTOR or by its sub-CONTRACTOR.
  - d) Proof of re-export of all items including the unutilized spares and consumables (excepting consumables consumed during the contract period) and also cancellation of re-export bond if any.
  - e) Any other documents as required by applicable Indian Laws.

In case, no demobilization charges are payable, the documents mentioned above will have to be submitted by the CONTRACTOR before release of the final payment by the COMPANY. A certificate from Chartered Accountant on (a), (b) & (c) above will suffice

- 27.12** CONTRACTOR shall maintain complete and correct records of all information on which CONTRACTOR's invoice are based upto 02 (two) years from the date of last invoice. Such records shall be required for making appropriate adjustments or payments by either party in case of subsequent audit query/objection.

**28.0 PAYMENT OF COMMISSION/FEE/REMUNERATION OF INDIAN AGENT/CONSULTANT/REPRESENTATIVE/RETAINER/ASSOCIATE OF FOREIGN PRINCIPAL (APPLICABLE IN ICB TENDERS ONLY):**

The Commission/Fee/remuneration of the Indian agent/consultant/associate/representative/retainer, if any, will be paid within 30 days of the payment of invoice made to the CONTRACTOR, The amount of commission/fee/remuneration as a percentage of invoice value as per contract provisions will be deducted by COMPANY/OIL from the monthly invoices of the CONTRACTOR and paid to the Indian agent/consultant/representative/retainer/associate.

**29.0 DETAILS OF STATUTORY PAYMENTS LIKE EPF AND ESI, ETC:**

Wherever applicable, the CONTRACTOR (including those engaging 'International Workers') shall have itself registered under Employees' Provident Fund and Miscellaneous Provisions Act, 1952 and Employees' State Insurance Act, 1948 and follow the relevant statutory provisions including Rules made there-under concerning contractual workers.

The CONTRACTOR shall be required to submit the following documents/details to the

## **E-TENDER: CGI7847P25**

Corporation:

- (i) Copy of PF-ECR duly stamped by the designated Bank, alongwith a print of the digitally signed PDF data sheet of the ECR, as proof of payment, each month, details of this PDF data sheet shall be verified by the appropriate authority (i.e. Payment Making Authority) in the COMPANY from the official website of EPFO (<http://www.epfindia.gov.in>).
- (ii) (a) Copy of the online challan endorsed/stamped by the designated bank as proof of receipt of payment towards monthly contribution of ESI contribution.  
  
(b) Copy of Return of contribution in respect of ESI for each contribution period of the six months i.e. for the contribution period ended 30th Sept and the contribution period ended 31st March.
- (iii) As an Annexure to each EPF-ECR and ESI Challan(s), CONTRACTOR shall also furnish the following Certificates:
  - 1) The furnished information is correct to the best of his knowledge.
  - 2) In case any discrepancies or irregularities is /are noticed in this undertaking, then OIL is free to inform the PF/ESIC Authorities.
  - 3) Before the completion of contract, CONTRACTOR shall serve one-month notice to all his contractual workers, informing that their services will be terminated.
  - 4) Within one month on completion/expiry of the contract, CONTRACTOR shall pay all the dues/ terminal dues such as leave with wages, bonus (if applicable), Gratuity (if applicable), to all his contractual workmen, failing which CONTRACTOR's Bank Guarantee/ Security Deposit may be withheld by OIL.

COMPANY may verify the deposit of statutory contribution made by the CONTRACTORS with the EPFO/ESI authorities, where deemed necessary. However, before making payment of the last bill/invoice of the CONTRACTOR, the COMPANY may verify the details/status of the payment towards EPF/ESI made by the CONTRACTOR from the authorities/official website of EPF/ESI (i.e. <http://www.epfindia.gov.in> and <http://www.esic.in>). In case the information furnished by the CONTRACTOR is found to be incorrect the COMPANY shall take appropriate action against the CONTRACTOR in accordance with law.

The CONTRACTOR agrees and undertakes to indemnify OIL for any liabilities arising out of declarations made by him in future on violation or provisions of the EPF Act 1952 and ESI Act 1948.

### **30.0 TIMELY MOBILIZATION AND LIQUIDATED DAMAGES:**

- a) Time is the essence of this Contract. If the CONTRACTOR fails to mobilize and deploy the required manpower/equipment and/or fails to commence the operation within the period specified as specified under mobilization clause under SCC, OIL shall have, without prejudice to any other right or remedy in law or contract including sub clause (b) below, the right to terminate the contract.
- b) If the contractor is unable to mobilize/deploy and commence the operation within the

**E-TENDER: CGI7847P25**

period specified in sub clause (a) above, it may request OIL for extension of the time with unconditionally agreeing for levy and recovery of LD. Upon receipt of such a request, OIL may at its discretion, extend the period of mobilization and shall recover from the CONTRACTOR, as an ascertained and agreed Liquidated Damages, a sum equivalent to @ 0.5% of contract value including mobilization cost, per week or part thereof of delay subject to maximum of 7.5% of the Contract Price.

- c) The parties agree that the sum specified above is not a penalty but a genuine pre-estimate of the loss/damage which will be suffered by OIL on account of delay on the part of the CONTRACTOR and the said amount will be payable without proof of actual loss or damage caused by such delay.
- d) LD will be calculated on the basis of Total Contract value [(if not specified otherwise in SCC] excluding duties and taxes, where such duties/taxes have been shown separately in the contract. However, the applicable GST on the LD shall have to be borne by the CONTRACTOR. Accordingly, the liquidated damages shall be recovered from the CONTRACTOR along with applicable GST.

**31.0 FORCE MAJEURE:**

In the event of either party being rendered unable by 'Force Majeure' to perform any obligation required to be performed by them under the contract, the relative obligation of the party affected by such 'Force Majeure' will stand suspended as provided herein. The term force majeure as employed herein shall mean Acts of God such as earthquake, hurricane, typhoon, flood, volcanic activity etc.; war (declared /undeclared); riot, revolts, rebellion, terrorism, sabotage by persons other than the CONTRACTOR's Personnel; fires, explosions, ionising radiation or contamination by radio-activity or noxious gas, if not caused by CONTRACTOR's fault; declared epidemic or disaster; acts and regulations of respective Govt. of the two parties, namely the COMPANY and the CONTRACTOR and civil commotions, lockout not attributable to the CONTRACTOR.

Upon occurrence of such cause, the party claiming that it has been rendered unable as aforesaid thereby, shall notify the other party in writing within 72 (Seventy Two) hours of the alleged beginning and ending thereof, giving full particulars and satisfactory evidence in support of its claim.

Should 'force majeure' condition as stated above occurs and should the same be notified within 72 (Seventy two) hours after its occurrence the 'force majeure' rate (if specified in the SCC of the Contract) shall apply for the first 15 (fifteen) days for each such occasion.

Either party shall have the right to terminate the Contract if such 'force majeure' conditions continue beyond successive 60 (Sixty) days [or exclusively mentioned in the SCC of the Contract] with prior written notice of 15 days, provided termination of the Contract does not result into safety hazard to the life and property on account of withdrawal of operations or the operation is at critical stage. COMPANY shall have the absolute right to decide whether any safety hazard exists or operation is at critical position and decision of the COMPANY shall binding upon the CONTRACTOR.

Should either party decide not to terminate the Contract even under such condition, no payment would apply after expiry of fifteen (15) days force majeure period. [or exclusively mentioned in the SCC of the Contract]

## **E-TENDER: CGI7847P25**

Time for performance of the relative obligation suspended by Force Majeure shall then stand extended by the period for which such cause lasts.

If however, relative obligation of the party affected by such 'Force Majeure' is limited to part of the obligation(s), the contract shall not be terminated and the parties shall continue to perform their respective obligations, which are not affected by the 'force majeure' condition, provided the obligations affected by the 'force majeure' do not preclude the parties in performing the obligations not affected by such conditions.

### **32.0 SET-OFF:**

Any sum of money due and payable to the CONTRACTOR (including Performance Security refundable to them) under this or any other Contract, whether in progress or in future, may be appropriated by OIL and set-off against any claim of OIL (or such other person or persons contracting through OIL) for payment of a sum of money arising out of this contract or under any other contract made by the CONTRACTOR with OIL (or such other person or persons contracting through OIL).

### **33.0 WITHHOLDING:**

COMPANY may withhold or nullify the whole or any part of the amount due to CONTRACTOR, after informing the CONTRACTOR of the reasons in writing, on account of subsequently discovered evidence in order to protect COMPANY from loss on account of :

- 33.1** For non-completion of jobs assigned as per Scope of Work/Terms of Reference.
- 33.2** Defective work not remedied by CONTRACTOR.
- 33.3** Claims by COMPANY's recognized sub-CONTRACTOR of CONTRACTOR or others filed or on the basis of reasonable evidence indicating probable filing of such claims against CONTRACTOR.
- 33.4** Failure of CONTRACTOR to pay or provide for the payment of salaries/ wages, contributions, taxes or enforced savings with-held from wages etc with respect to personnel engaged by the CONTRACTOR.
- 33.5** Failure of CONTRACTOR to pay the cost of removal of unnecessary debris, materials, tools, or machinery.
- 33.6** Any failure by CONTRACTOR to fully reimburse COMPANY under any of the indemnification provisions of this Contract. If, during the progress of the work CONTRACTOR shall allow any indebtedness to accrue for which CONTRACTOR, under any circumstances in the opinion of COMPANY, may be primarily or contingently liable or ultimately responsible and CONTRACTOR shall, within five days after demand is made by COMPANY, fail to pay and discharge such indebtedness, then COMPANY may during the period for which such indebtedness shall remain unpaid, with-hold from the amounts due to CONTRACTOR, a sum equal to the amount of such unpaid indebtedness.
- 33.7** Withholding will also be effected on account of the following:
  - i) Order issued by a Court of Law or statutory authority in India.

## **E-TENDER: CGI7847P25**

- ii) Income-tax deductible at source according to law prevalent from time to time in the country.
- iii) Any obligation of CONTRACTOR which by any law prevalent from time to time to be discharged by COMPANY in the event of CONTRACTOR's failure to adhere to such laws.
- iv) Any payment due from CONTRACTOR in respect of unauthorised imports.

When all the above grounds for withholding payments are removed, payment shall thereafter be made for amounts so with-held.

**33.8** COMPANY reserves the right to disburse or deposit the amount so withheld to the concerned person(s) or agency or government authority, as the case may be, besides nullifying such amount on account of loss suffered by the COMPANY against **33.2, 33.3, 33.6 & 33.7** above.

### **34.0 APPLICABLE LAWS:**

The Contract shall be deemed to be a Contract made under, governed by and construed in accordance with the laws of India for the time being in force and shall be subject to the sole and exclusive jurisdiction of Courts situated in Dibrugarh (or the Place where the contract is executed) and Principal Bench of Gauhati High Court (or the High Court under whose territorial jurisdiction, the place of execution of contract falls).

This Agreement including all matter connected with this Agreement, shall be governed by the laws of India (both substantive and procedural) for the time being in force and shall be subject to exclusive jurisdiction of Courts, mentioned hereinabove. Foreign companies, operating in India or entering into Joint ventures in India, shall also be governed by the laws of India and shall be subject to sole and exclusive jurisdiction of above Courts.

The CONTRACTOR shall ensure full compliance of various Indian Laws and Statutory Regulations, as stated below, to the extent applicable, as stated below, but not limited to, in force from time to time and obtain necessary permits/ licenses etc. from appropriate authorities for conducting operations under the Contract:

- a) The Mines Act 1952
- b) The Oil Mines Regulations, 1984
- c) The Employees' Compensation Act, 1923
- d) The Code of Wages, 2019
- e) The Contract Labour (Regulation & Abolition) Act, 1970 and the rules framed there under
- f) The Employees Pension Scheme, 1995
- g) The Interstate Migrant Workmen Act., 1979 (Regulation of employment and conditions of service).
- h) The Employees Provident Fund and Miscellaneous Provisions Act, 1952

**E-TENDER: CGI7847P25**

- i) Goods and Service Tax Act
- j) Customs & Excise Act & Rules
- k) Factories Act, 1948
- l) Industrial Disputes Act, 1947
- m) Payment of Gratuity Act, 1972
- n) Environmental Protection Act, 1986 & other pollution control Acts.

Note: The above Acts are only indicative and not exhaustive. The Acts shall include the rules and regulations framed thereunder.

**35.0 LABOUR LAWS:**

- i) CONTRACTOR shall comply with the provisions of various labour related laws, including but not limited to the Code of Wages, 2019, Employee Provident Fund and Miscellaneous Provisions Act 1952, COMPANY's Liability Act 1938, Employees' Compensation Act 1923, Industrial Disputes Act 1947, the Maternity Benefit Act 1961 and Contract Labour (Regulation and Abolition) Act 1970, Employment of Children Act 1938, Employees' State Insurance Act, 1948 or any modifications/amendment thereof or any other law relating thereto and rules made there under from time to time.
- ii) No Labour below the age of eighteen [18] years shall be employed on the work.
- iii) CONTRACTOR shall not pay less than what is provided under law to labourers engaged by him on the work.
- iv) CONTRACTOR shall at his expense comply with all labour laws and keep the COMPANY indemnified in respect thereof.
- v) CONTRACTOR shall pay equal wages for men and women in accordance with applicable Labour laws.
- vi) If the CONTRACTOR is covered under the Contract Labour (Regulation and Abolition) Act, he shall obtain a license from licensing authority [i.e. office of the Labour Commissioner] by payment of necessary prescribed fee and the deposit, if any, before starting the work under the Contract. Such fee/deposit shall be borne by the CONTRACTOR.
- vii) CONTRACTOR must obtain the PF Code from the concerned PF Authority under Employees Provident Fund and Miscellaneous Provisions Act, 1952. Similarly, CONTRACTOR must obtain ESI Code under Employees State Insurance Act.
- viii) CONTRACTOR being the employer of the labours/personnel to be engaged under the contract shall be liable to pay gratuity to the labours/personnel as per the provision of the Payment of Gratuity Act, 1972 and accordingly, shall keep the COMPANY

## **E-TENDER: CGI7847P25**

indemnified in respect thereof. If however, COMPANY requires to pay gratuity to such labour(s) as per the direction of the competent authority under the Act, COMPANY shall recover such amount from the outstanding dues payable to the CONTRACTOR under the contract or any other contract(s).

- ix) CONTRACTOR shall furnish to Engineer in Charge the distribution return of the number & description, by trades of the work people employed on the works. CONTRACTOR shall also submit on the 4th & 19th of every month to Engineer in Charge a true statement showing in respect of the 2nd half of the preceding month & the 1st half of the current month (1) the accidents that occurred during the said fortnight showing the circumstances under which they happened and the extent of damage and injury caused by them and (2) the number of female workers who have been allowed Maternity Benefit as provided in the Maternity Benefit Act 1961 on Rules made there under and the amount paid to them.
- x) Engineer in Charge shall on a report having been made by an inspecting officer as defined in Contract Labour (Regulation and Abolition) Act 1970 have the power to deduct from the money due to the CONTRACTOR any sum required or estimated to be required for making good the loss suffered by a worker or workers by reason of non-fulfillment of the conditions of the Contract for the benefit of workers, non-payment of wages or of deductions made from his or their wages which are not justified by the terms of the Contract or non-observance of the said regulations.
- xi) The CONTRACTOR shall indemnify the COMPANY against any payments to be made under and for the observance of the provisions of the aforesaid acts without prejudice to his right to obtain indemnity from his sub-CONTRACTOR.

### **36.0 STATUTORY REQUIREMENTS:**

During the tenure of this CONTRACT nothing shall be done by the CONTRACTOR in contravention of any law, act and/or rules/regulations, thereunder or any amendment

#### **37.0 GENERAL HEALTH, SAFETY & ENVIRONMENT (HSE) GUIDELINES:**

- 37.1** It will be solely the CONTRACTOR's responsibility to fulfil all the legal formalities with respect to the Health, Safety and Environmental aspects of the entire job (namely; the person employed by him, the equipment, the environment, etc.) under the jurisdiction of the district of that state where it is operating. Ensure that all sub- CONTRACTORs hired by CONTRACTOR comply with the same requirement as the CONTRACTOR himself and shall be liable for ensuring compliance all HSE laws.
- 37.2** It will be entirely the responsibility of the Contractor/his Supervisor/representative to ensure strict adherence to all HSE measures and statutory rules during operation in OIL's installations and safety of workers engaged by him. The crew members will not refuse to follow any instruction given by company's Installation Manager/Safety Officer/Engineer/Official/ Supervisor/Junior Engineer for safe operation.
- 37.3** Any compensation arising out of the job carried out by the Contractor whether related to pollution, Safety or Health will be paid by the contractor only.

**E-TENDER: CGI7847P25**

- 37.4** Any compensation arising due to accident of the Contractor's personnel while carrying out the job, will be payable by the contractor.
- 37.5** When there is a significant risk to health, environment or safety of a person or place arising because of a non-compliance of HSE Measures Company shall have the right to direct the contractor to cease work until the non-compliance is corrected.

**38.0 POLLUTION AND CONTAMINATION:**

The CONTRACTOR shall be liable for all surface and sub-surface pollution to the extent caused by CONTRACTOR and resulting from CONTRACTOR's operation/service or spillage or dumping of solvents/additive substances or pollutants, which the CONTRACTOR brings to the Site for use in connection with Work to be performed under this Contract.

Notwithstanding anything to the contrary contained herein, it is agreed that except on the ground of willful misconduct or criminal misconduct, COMPANY shall release, indemnify and hold CONTRACTOR and its sub-CONTRACTORS harmless from any and all claims, judgments, losses, expenses and any costs related thereto (including but not limited to Court costs and "Attorney's fees") for:

- a) Damage to or loss of any reservoir or producing formation; and/ or
- b) Damage to or loss of any well; and/ or
- c) Any other subsurface damage or loss; and/ or
- d) Any property damage or loss or personal injury or death arising out of or in connection with a blowout, fire explosion and loss of well control regardless of cause.

**39.0 STATUTORY VARIATION/ NEWLY ENACTED LAW:**

- 39.1** All duties, taxes except otherwise specified in the Contract as applicable on the closing date of bid submission as per relevant acts and rules shall be in CONTRACTOR's account. Variation in case of custom duty on CIF value declared by the bidder shall be to COMPANY account.
- 39.2** In the event of introduction of any new legislation or any amendment or enforcement of any Act or Law, rules or regulations of Government of India or State Government(s) or Public Body, which becomes effective after the date of submission of Price Bid or revised price bid, if any, for this CONTRACT and which results in increased/decreased cost of the works under the CONTRACT through increased/decreased liability of taxes and/or duties, required to be paid by the CONTRACTOR, (other than personnel and Corporate taxes), the Parties shall agree to a revision in pricing to reflect such change subject to the production of documentary proof to the satisfaction of the COMPANY/CONTRACTOR as applicable to the extent which directly is attributable to such introduction of new legislation or change

**E-TENDER: CGI7847P25**

or amendment as mentioned above and adjudication by the competent authority (applicable when disputed by COMPANY) & the courts wherever levy of such taxes/duties are disputed by COMPANY/CONTRACTOR.

- 39.3** Any increase in net amount of the duties and taxes (i.e. the amount of taxes/duties payable minus eligible credit of taxes/duties paid on input services/inputs) after the contractual completion/mobilization date during the extended period will be to the CONTRACTOR's account, where delay in completion /mobilization period is attributable to the CONTRACTOR. However, any decrease in net amount of the duties and taxes (i.e. the amount of taxes/duties payable minus eligible credit of taxes/duties paid on input services/inputs) after the contractual completion/mobilization date will be to COMPANY's account.
- 39.4** The Contract Price and other prices given in the Schedule of Prices are based on the applicable tariff as indicated by the CONTRACTOR in the Schedule of Prices. In case this information subsequently proves to be wrong, incorrect or misleading, COMPANY will have no liability to reimburse/pay to the CONTRACTOR the excess duties, taxes, fees, if any finally levied/imposed by the concerned authorities. However, in such an event, COMPANY will have the right to recover the difference in case the rate of duty/tax finally assessed is on the lower side.
- 39.5** Notwithstanding the provision contained in Clause-39.1 to 39.4 above, the COMPANY shall not bear any liability in respect of:
- i. Personal taxes on the personnel deployed by CONTRACTOR, his sub-CONTRACTOR/sub-sub-CONTRACTORS and Agents etc.
  - ii. Corporate taxes and Fringe benefit tax in respect of CONTRACTOR and all of their sub-CONTRACTORS, agents etc.
  - iii. Other taxes & duties including Customs Duty and GST in addition to new taxes etc. in respect of sub-CONTRACTORS, vendors, agents etc. of the CONTRACTOR.
  - iv. Any liability on the CONTRACTOR, which was accrued under the old law or contract, which the CONTRACTOR is obligated to pay either to the COMPANY or to the Government Authority.
- 39.6** In order to ascertain the net impact of the amendment/ revisions/enactment of various provisions of taxes/duties, the CONTRACTOR is liable to provide following disclosure to COMPANY:
- i. Details of each of the input services used in relation to providing service to COMPANY including estimated monthly value of input service and GST tax amount.
  - ii. Details of Inputs (material/consumable) used/required for providing service to COMPANY including estimated monthly value of input and GST paid/payable on purchase of inputs.
- 39.7** The above provisions would be applicable only in case of variation in rate of taxes and

**E-TENDER: CGI7847P25**

duties on supply of services to OIL and not applicable on taxes and duties on input (goods and services) towards such services.

- 39.8** Any claim or reduction on account of change in law shall be accompanied with undertaking that the provisions of anti- profiteering clause under GST Act have been complied with.

**40.0 SEVERABILITY:**

Should any provision of this agreement be found to be invalid, illegal or otherwise not enforceable by any court of law, such finding shall not affect the remaining provisions hereto and they shall remain binding on the parties hereto.

**41.0 COMMISSION OF MISCONDUCT/SUBMISSION OF FRAUDULENT DOCUMENT BY THE BIDDER/CONTRACTOR AND BANNING THEREOF:**

The information and documents furnished by the bidder/CONTRACTOR in respect of the tender/contract are accepted by COMPANY to be true and genuine. However, if it comes to the notice of the COMPANY anytime either during the pendency of the tender or after award of the contract or after completion the contract that a Bidder/CONTRACTOR furnished fraudulent document/false information in relation to the subject tender/contract or committed any misconduct, appropriate action shall be taken against the Bidder/CONTRACTOR for debarment/banning of the bidder/CONTRACTOR from participating in any future tender of the COMPANY in terms of the COMPANY's Banning Policy, 2017 besides making the CONTRACTOR liable for other penal action including termination of ongoing contract(s) at his/her risk and peril. In such event, the Performance Security in respect of ongoing contract(s) shall be forfeited by the COMPANY.

**42.0 SETTLEMENT OF DISPUTES:**

- 42.1** If dispute of any kind whatsoever shall arise between the company and the contractor in connection with or arising out of the contract, including without prejudice to the generality of the foregoing, any question regarding its existence, validity or termination, or the execution of the facilities, whether during the progress of the facilities or after their completion and whether before or after the termination, abandonment or breach of the contract, the parties shall seek to resolve any such dispute or difference by mutual consultation. If the parties fail to resolve any such dispute or difference by mutual consultation, then the dispute may be settled through Settlement Advisory Committee (SAC). In the event, a dispute remains unsettled then Arbitration/ other remedies available under the applicable laws may be availed by the Contractor.

**42.2 Resolution of Dispute through SAC:**

- a) OIL has framed the Conciliation Rules 2020 in conformity with Part III of the Arbitration and Conciliation Act 1996 as amended from time to time for speedier, cost effective and amicable settlement of disputes through conciliation.
- b) If the parties fail to resolve such a dispute or difference by mutual consultation as per

**E-TENDER: CGI7847P25**

clause no. 42.1, the dispute, if the parties agree, may be referred to conciliation in accordance with OIL Conciliation Rules 2020 as amended from time to time. A copy of the said Rules has been made available on OIL's Website

i.e. [www.oil-india.com](http://www.oil-india.com)

- c) Where the invitation for conciliation has been accepted by the other party, the parties shall attempt to settle such dispute(s) amicably under OIL conciliation Rules 2020.
- d) Parties shall invoke arbitration clauses only after exhausting the option of conciliation as an Alternative Dispute Resolution Mechanism. For the purpose of this clause, the option of conciliation shall be deemed to have been exhausted, even in case of rejection of conciliation by any of the parties.

**42.3 Arbitration (Applicable for Suppliers/Contractors other than PSU and MSME):**

- 1. Except as otherwise provided elsewhere in the contract, if any dispute, difference, question or disagreement arises between the parties hereto or their respective representatives or assignees, in connection with construction, meaning, operation, effect, interpretation of the contract or breach thereof which parties are unable to settle mutually through Conciliation/Mediation, the same shall be referred to Arbitration.
- 2. A party wishing to commence arbitration proceeding shall invoke an Arbitration Clause by giving 30 days' notice to the other party. The notice invoking arbitration shall specify all the points of dispute with details of the amount claimed to be referred to arbitration at the time of invocation of arbitration and not thereafter. If the claim is in foreign currency, the claimant shall indicate its value in Indian Rupee for the purpose of constitution of the arbitral tribunal.
- 3. The number of arbitrators and the appointing authority will be as under: Claim amount (excluding claim for interest and counter claim, if any)

<b>Claim amount. {excluding claim for interest and counter claim, if any}</b>	<b>Number of Arbitrator</b>	<b>Appointing Authority</b>
Up to Rs. 25.00 Lakh	Not applicable	Not applicable

**E-TENDER: CGI7847P25**

Above Rs. 25.00 Lakh Up to Rs. 5 Crore	Sole Arbitrator from the panel of Arbitrators' List maintained by OIL	Mutually to be decided by the Parties.
--	---	--

4. The Parties agree that dispute involving claims below Rs. 25 lakhs and above Rs. 5 crores shall not be subject matter of Arbitration but subject to the exclusive jurisdiction of the Court(s) situated at New Delhi.
5. The parties agree that they shall appoint only those persons as arbitrators who accept the conditions of the arbitration clause. No person shall be appointed as Arbitrator or Presiding Arbitrator who does not accept the conditions of the arbitration clause.
6. If any of the Arbitrators so appointed dies, resigns, becomes incapacitated or withdraws for any reason from the proceedings, it shall be lawful for the concerned party/arbitrators to appoint another person in his place in the same manner as aforesaid. Such person shall proceed with the reference from the stage where his predecessor had left if both parties consent for the same; otherwise, he shall proceed de novo.
7. Parties agree and undertake that neither shall be entitled for any pre- reference or pendente-lite interest on its claims. Parties agree that any claim for such interest made by any party shall be void. Parties agree that a claim for any such interest shall not be considered and shall be void. The Arbitrator or Tribunal shall have no right to award pre-reference or pendent-lite interest in the matter.
8. The arbitral tribunal shall complete the proceedings, make and publish the award within time stipulated in the Arbitration and Conciliation Act, 1996(as amended from time to time)
9. If after commencement of the arbitration proceedings, the parties agree to settle the dispute mutually or refer the dispute to conciliation, the arbitrators shall put the proceedings in abeyance until such period as requested by the parties. Where the proceedings are put in abeyance or terminated on account of mutual settlement of dispute by the parties, the fees payable to the arbitrators shall be determined as under:
  - a) 20% of the fees if the claimant has not submitted a statement of claim.
  - b) 40% of the fees if the pleadings are complete.
  - c) 60% of the fees if the hearing has commenced.
  - d) 80% of the fees if the hearing is concluded but the award is yet to be passed.

## **E-TENDER: CGI7847P25**

10. Each party shall be responsible to make arrangements for the travel and stay etc. of the arbitrator appointed by it. Claimant shall also be responsible for making arrangements for travel and stay of the Presiding Arbitrator and the expenses incurred shall be shared equally by the parties. In the case of sole arbitrator, both parties shall equally share all expenditures that may be required to be incurred.
11. The fees and other administrative/secretarial expenses of the arbitrator(s) shall not exceed the model fee as stipulated in the Schedule of the Act and such expenses shall be equally borne by the parties.
12. The seat and venue of the arbitration proceeding shall be New Delhi.

### **42.4 Arbitration (applicable in case of Contract awarded on Public Sector Enterprise):**

1. If the Parties fail to resolve such a dispute or differences by Mutual Consultation/Good Faith Discussions, such disputes or difference shall be taken up by either party for resolution through Administrative Mechanism for Resolution of CPSEs Disputes (AMRCD) as mentioned in DPE Office Memorandum No. 05/0003/2019-FTS-10937 dated 14.12.2022 issued by Department of Public Enterprises, Ministry of Heavy Industries and Public Enterprises, Government of India and its further clarifications, modifications and amendments, issued from time to time.
2. A party wishing to commence arbitration proceedings shall invoke Arbitration Clause and refer the dispute(s) to AMRCD with a copy to the other party. The notice invoking arbitration shall specify all the points of dispute with details of the amount claimed to be referred to arbitration at the time of invocation of arbitration and not thereafter.
3. Upon such reference, the dispute shall be decided by the Competent Authority appointed under the AMRCD, whose decision shall bind the parties finally and conclusively. The parties in the dispute will share equally the cost of the arbitration as intimated by the Arbitrator.

### **42.5 Arbitration (Applicable to Micro, Small and Medium Enterprise)**

In the event of any dispute or difference relating to, arising from, or connected with the Contract, efforts shall be made to resolve the dispute(s) amicably by mutual consultation and in case such dispute(s) cannot be resolved through mutual consultation, then same shall be resolved through the procedure as prescribed in Section-18 of the Micro, Small and Medium Enterprises Development Act, 2006.

### **42.6 Exclusions**

Parties agree that following matters shall not be referred to conciliation or arbitration:

- a) Any claim, difference or dispute relating to, connected with or arising out of OIL's decision to initiate any proceedings for suspension or debarment or banning, or decision to suspend or to ban or to debar business dealings with the

**E-TENDER: CGI7847P25**

bidder/CONTRACTOR and/or with any other person involved or connected or dealing with bid/contract/bidder/CONTRACTOR.

- b) Any claim, difference or dispute relating to, connected with or arising out of OIL's decision under the provisions of Integrity Pact executed between OIL and the Bidder/CONTRACTOR.
- c) Any claim, difference or dispute relating to, connected with or arising out of OIL's decision to comply with any order or directive of any statutory or government authority.

**43.0 COMPLETION OF CONTRACT:**

Unless otherwise terminated under the provisions of any other relevant Clause or extended through written communication, this Contract shall be deemed to have been completed at the expiry of the Period specified in the contract or period of defect liability, as provided for under the Contract, whichever is later.

**44.0 TERMINATION:**

**44.1 Termination on expiry of the contract:** This Agreement shall be deemed to have been automatically terminated on the expiry of the contract period unless OIL has exercised its option to extend this contract in accordance with the provisions, if any, of this contract.

**44.2 Termination of contract for death:** If the CONTRACTOR is an individual or a proprietary concern and the individual or the proprietor dies or if the CONTRACTOR is a partnership concern and one of the partners dies then unless, the COMPANY is satisfied that the legal heir of the individual or the proprietary concern or the surviving partners are capable of carrying out and completing Contract, the COMPANY is entitled to cancel the Contract for the uncompleted part without being in any way liable for any compensation payment to the estate of the deceased CONTRACTOR and/or to the surviving partners of the CONTRACTOR's firm on account of the cancellation of Contract. The decision of the COMPANY in such assessment shall be final & binding on the parties. In the event of such cancellation, the COMPANY shall not hold the estate of the deceased CONTRACTOR and/or the surviving partners of CONTRACTOR's firm liable for any damages for non- completion of the Contract.

**44.3 Termination on account of Force Majeure:** Unless the contract provides otherwise, either party shall have the right to terminate this Contract on account of Force Majeure as set forth in Article-31.0 above.

**44.4 Termination on account of insolvency:** In the event that the CONTRACTOR or its collaborator or its guarantor at any time during the term of the Contract, becomes insolvent or makes a voluntary assignment of its assets for the benefit of creditors or is adjudged bankrupt or under the process of insolvency or liquidation, then the COMPANY shall, by a notice in writing have the right to terminate the Contract and all the CONTRACTOR's rights and privileges hereunder, shall stand terminated forthwith.

## **E-TENDER: CGI7847P25**

However, COMPANY shall be at liberty to give the Receiver or Liquidator or Insolvency Professional Manager, as appointed by the Competent Court/Tribunal, the option of carrying out the Contract subject to its technical & financial competence and his providing a guarantee for due and faithful performance of the Contract.

- 44.5 Termination for Unsatisfactory Performance:** If the COMPANY considers that, the performance of the CONTRACTOR is unsatisfactory, or not as per the provision of the Contract, the COMPANY shall notify the CONTRACTOR in writing and specify in details the cause of dissatisfaction. The COMPANY shall have the option to terminate the Contract by giving 15 days notice in writing to the CONTRACTOR, if CONTRACTOR fails to comply with the requisitions contained in the said written notice issued by the COMPANY. In the event CONTRACTOR rectifies its non-performance to the satisfaction of the COMPANY, the option of termination may not be exercised by the COMPANY. If however CONTRACTOR repeats non-performance subsequently, COMPANY shall exercise the option to terminate contract by giving 07 days notice. Such CONTRACTOR shall be put on holiday as per the Banning Policy of OIL [available at [www.oil-india.in](http://www.oil-india.in)].
- 44.6 Termination due to change of ownership and Assignment:** In case the CONTRACTOR's rights and /or obligations under this Contract and/or the CONTRACTOR's rights, title and interest to the equipment/ material, are transferred or assigned without the COMPANY's written consent, the COMPANY may at its option, terminate this Contract. COMPANY shall not be however under any obligation to accord consent to the CONTRACTOR for change of ownership & assignment of the contract.
- 44.7** If at any time during the term of this Contract, breakdown of CONTRACTOR's equipment results in CONTRACTORS being unable to perform their obligations hereunder for a period of 15 successive days, COMPANY at its option, may terminate this Contract in its entirety or partially to the extent non-performance, without any further right or obligation on the part of the COMPANY, except for the payment of money then due. No notice shall be served by the COMPANY under the condition stated above.
- 44.8 Termination for delay in mobilization:** CONTRACTOR is required to mobilize complete equipment alongwith crew for commencement of services at the specified site within the maximum allowed number of days from the date of LOA/Notice for Mobilization as specified in the special conditions of contract. If the CONTRACTOR (successful bidder) fails to complete the mobilization as above, OIL shall have, without prejudice to any other clause of the CONTRACT, the right to terminate the contract.
- 44.9** Notwithstanding any provisions herein to the contrary, the Contract may be terminated at any time by the COMPANY on giving 30 (thirty) days written notice to the CONTRACTOR due to any other reason not covered under the above Article from
- 44.1 to 44.8** and in the event of such termination the COMPANY shall not be liable to pay any cost or damage to the CONTRACTOR except for payment of services as per the Contract upto the date of termination.
- 44.10 Consequence of Termination:** In all cases of termination herein set forth, the relative obligations of the parties to the Contract shall be limited to the period up to the date

## **E-TENDER: CGI7847P25**

of termination. Notwithstanding the termination of this Contract, the parties shall continue to be bound by the provisions of this Contract that reasonably require some action or forbearance after such termination.

Upon termination of this Contract, CONTRACTOR shall return to COMPANY all of COMPANY's properties, which are at the time in CONTRACTOR's possession.

In the event of termination of contract, COMPANY will issue Notice of termination of the contract with date or event after which the contract will be terminated. The contract shall then stand terminated and the CONTRACTOR shall demobilize their personnel & materials.

Demobilization charges shall not be payable by COMPANY in case of Article from **44.4 to 44.7**

### **45.0 TO DETERMINE THE CONTRACT:**

In such an event (i.e. termination under Article No. 44.4 to 44.9 above), the contract shall stand terminated and shall cease to be in force from the date of such notification by the COMPANY. Thereafter the CONTRACTOR shall stop forthwith any of the work then in progress, except those work which the COMPANY may, in writing, require to be done to safeguard any property or work, or installations from damages, and the COMPANY may take over the remaining unfinished work of the CONTRACTOR and complete the same through a fresh CONTRACTOR or by other means, at the risk and cost of the CONTRACTOR, and any of its sureties if any, shall be liable to the COMPANY for any excess cost occasioned by such work having to be so taken over and completed by the COMPANY over and above the cost at the rate/cost specified in the schedule of quantities and rates/prices.

**46.0 WITHOUT DETERMINING THE CONTRACT:** In such an event (i.e. termination under Article No. 44.4 to 44.9 above), the COMPANY may take over the work of the CONTRACTOR or any part thereof and complete the same through a fresh CONTRACTOR or by other means, at the risk and cost of the CONTRACTOR. The CONTRACTOR and any of its sureties are liable to the COMPANY for any excess cost over and above the cost at the rates specified in the schedule of quantities and rates/prices, occasioned by such work having been taken over and completed by the COMPANY.

### **47.0 ERRING/DEFAULTING AGENCIES:**

Erring and defaulting agencies like bidder, CONTRACTOR, supplier, vendor, service provider will be dealt as per OIL's Banning Policy dated 6th January, 2017 available in OIL's website: [www.oil-india.com](http://www.oil-india.com). Moreover, OIL reserves the right to take legal or any other action on the basis of merit of the case.

### **48.0 MISCELLANEOUS PROVISIONS:**

CONTRACTOR shall give notices and pay all fees at their own cost required to be given or paid by any National or State Statute, Ordinance, or other Law or any regulation, or bye-law of any local or other duly constituted authority as may be in force from time to time in India, in relation to the performance of the services and by the rules & regulations of all public bodies and companies whose property or rights are affected or may be affected in any way by the services.

CONTRACTOR shall conform in all respects with the provisions of any Statute, Ordinance of Law as aforesaid and the regulations or bye-law of any local or other duly constituted authority which may be applicable to the services and with such rules and regulation, public bodies and Companies as aforesaid and shall keep COMPANY indemnified against all penalties and liability of every kind for breach of any such Statute, Ordinance or Law, regulation or bye-law.

During the tenure of the Contract, CONTRACTOR shall keep the site where the services are being performed reasonably free from all unnecessary obstruction and shall store or dispose of any equipment and surplus materials and clear away and remove from the site any wreckage, rubbish or temporary works no longer required. On the completion of the services, CONTRACTOR shall clear away and remove from the site any surplus materials; rubbish or temporary works of every kind and leave the whole of the site clean and in workmanlike

**E-TENDER: CGI7847P25**

condition to the satisfaction of the COMPANY.

Key personnel cannot be changed during the tenure of the Contract except due to sickness/death/resignation of the personnel or any other justified situation in which case the replaced person should have equal experience and qualification, which will be again subject to prior approval, by the COMPANY.

**E-TENDER: CGI7847P25**

<b>PART - 4</b>		<b>SECTION - II</b>	
		<b>PART-4 SOQ</b>	
		<b>PROFORM A-A</b>	
	<b>OIL INDIA LIMITED</b>		
	<b>(A Govt. of India Enterprise)</b>		
<b>Maintenance of OFC cable and other Telecom activities for a period of two years extendable by another one year upon review under PS5 Sector(Row Chainage PLKM 352-497 &amp; Spur Line PHQ - GHY Refinery Termianl)</b>			
<b>SCHEDULE OF QUANTITIES (SOQ), SERVICE/WORK AND RATES</b>			
<b>TENDER NO :</b>			
<b>CGI7847P25</b>			
<b>SL.NO.</b>	<b>DESCRIPTION OF WORK</b>	<b>QTY</b>	<b>UNIT</b>
		<b>(A)</b>	

**E-TENDER: CGI7847P25**

<b>10</b>	<b>Skilled services for OFC maintenance:-</b> Providing Service of 4 nos. Skilled services for PS5 Telecom . Should have knowledge of OFC & OFC Equipments maintenance, Telephone handset maintenance , Telephone network maintenance,knowledge of computers, laying of OFC cable , Splicing, Link Failure analysis etc. Minimum 2 / 3 years experience of Similar nature in reputed organization / Firm is solicited. [Amount FIXED] . Monthly Fixed Charge includes PF,etc. as per applicable Wage Act. (4 Nos.X12 Months X2 Years X MONTHLY WAGES) <b>BIDDERS WILL NOT QUOTE IN THE BID.</b>	<b>96.00</b>	<b>MO N</b>
<b>20</b>	<b>Service Charge for Line Item 10: Service Charge</b> for Line Item 10( Up to a maximum ceiling of <b>3.85 %</b> ).	<b>96.00</b>	<b>MO N</b>

**E-TENDER: CGI7847P25**

<b>30</b>	<b>Skilled Services Overtime:</b> Supply of Skilled Services beyond 8 hours of normal duty. <b>BIDDERS WILL NOT QUOTE IN THE BID</b>	<b>2880.00</b>	<b>HR</b>
<b>40</b>	<b>Service Charge for Line item 30:</b> Service Charge for Line Item 30( Up to a maximum ceiling of 3.85 % ).	<b>2880.00</b>	<b>HR</b>

**E-TENDER: CGI7847P25**

<b>50</b>	<b>T A Skilled Services(w/o Night Halt):</b> Travelling allowance for Skilled (Without Night Halting). <b>BIDDERS WILL NOT QUOTE IN THE BID</b>	<b>720.00</b>	<b>NO</b>
<b>60</b>	<b>Service Charge Line item 50:</b> Service Charge for Line Item 50( Up to a maximum ceiling of 3.85 % ).	<b>720.00</b>	<b>NO</b>

**E-TENDER: CGI7847P25**

<b>70</b>	<b>Services of general unskilled services:</b> For all types of Telecom jobs. Supply of services for all types of jobs like trenching, digging, backfilling, boulder sausage net, CC work, cable pulling, Civil job help at ROW , support for Telecom jobs and also for any other labour jobs on as and when required basis for other Telecom related jobs during office hours minimum 8 hours . <b>BIDDERS WILL NOT QUOTE IN THE BID.</b>	<b>1500.00</b>	<b>NO</b>
<b>80</b>	<b>Service Charge Line item 70: Service Charge for Line Item 70( Up to a maximum ceiling of 3.85 % ).</b>	<b>1500.00</b>	<b>NO</b>
<b>90</b>	<b>Supply of Bamboo:</b> Good quality Bamboos as and when required.	<b>200.00</b>	<b>NO</b>
<b>100</b>	<b>Transportation of Heavy materials:</b> like RCC Chamber, RCC Marker Posts, Cables drum, Ducts, sand, etc. to the OFC repair site using Transport Vehicles etc. providing goods transport vehicle and vehicle operator is under contractor's scope	<b>1000.00</b>	<b>KM</b>

**E-TENDER: CGI7847P25**

<b>110</b>	<b>Hiring services of Excavator per day:</b> (8 hours maximum) inclusive of fuel and operator costs	<b>30.00</b>	<b>DAY</b>
<b>120</b>	<b>Supply of Sand to fill Splice Chambers:</b> Good quality Sand shall be supplied	<b>500.00</b>	<b>M3</b>
<b>130</b>	<b>Supply of Concrete Splicing Chamber:</b> CSC following specifications ( as per diagram 1 attached): 1 No CSC shall consist of following items : i) 2 Nos of RCC rings each of following specifications a) Height 25 cm b) Inner diameter 90 cm c) Thickness 10 cm d) RCC proportion 1:2:4 e) Reinforcement : 6 mm X 6 mm at 12.5 cm spacing ii) 3 nos RCC Cover Plates each of diameter 110 cm [ one full circle and two Semi circular] of following specifications a) Thickness 5 cm b) Diameter 110 cm c) RCC proportion 1:2:4 d) Reinforcement : 8 mmX 8 mm at 12.5 cm spacing. Supply of all materials including cement under contractor's scope Kindly collect the drawing from the concerned engineer before supply or bidding	<b>50.00</b>	<b>NO</b>

**E-TENDER: CGI7847P25**

<b>140</b>	<b>Supply overground RCC OFC marker post:</b> Fabrication of overground RCC OFC marker post with OIL and OFC engraved on either faces of three sides in ratio 1:2:4 (cement : Sand : Stone 20mm aggregate) . Base width each side shall be 12 inches and top shall be 4 inches . Height of the Marker Post shall be 3.5 ft with 8 mm vertical rod and 6 mm horizontal rod with 125 mm spacing between each ring from top to bottom. (as per diagram no 2 attached). Supply of all materials including cement under contractor's scope Kindly collect the drawing from the concerned engineer before supply or bidding.	<b>50.00</b>	<b>NO</b>
<b>150</b>	<b>Supply of signboards:</b> for various Telecom maintenance activities as per OIL's requirement	<b>50.00</b>	<b>NO</b>

**E-TENDER: CGI7847P25**

<b>160</b>	<b>Supply of cable route marker:</b> Dimensions 10 cm X 10 cm X 5 mm thick G.I. plate with inscription there on as advised by OIL , bolted / welded to 35 mm X 35 mm X 6 mm angle iron, 60 cm long and fixing the same in ground as required.Stenciling on the Plate as instructed by Telecom Section Kindly collect the drawing from the concerned engineer before supply or bidding.	<b>100.00</b>	<b>NO</b>
<b>170</b>	<b>HDD of OFC HDPE duct:</b> HDD of OFC HDPE duct of dia 40mm or more on as and when required. <b>HDPE ducts and OFC cable shall be provided by OIL</b>	<b>2500.00</b>	<b>M</b>
<b>180</b>	<b>Overhead OFC laying and pulling:</b> across poles, bamboo, tall structures etc. as per OIL's direction	<b>1000.00</b>	<b>M</b>

**E-TENDER: CGI7847P25**

<b>190</b>	<b>Services of Crane or Hydra:</b> for lifting heavy materials	<b>5.00</b>	<b>NO</b>
<b>200</b>	<b>Fabrication job of mild steel items:</b> including supply of material , grinding, weilding, painting etc.	<b>500.00</b>	<b>KG</b>
<b>210</b>	<b>Reimbursement of Insurance coverage:</b> for Skilled service Period of covergae two years No. of personnel under coverage Skilled services - four; [line Item (1)] Unskilled Services - for a group of maximum 10 [ten] under Workmen Insurance Compensation Act: 1923 . Shall be reimbursed on actuals after receipt of payment invoice or voucher. <b>Bidder need not quote</b>	<b>1.00</b>	<b>LS M</b>

**E-TENDER: CGI7847P25**

<b>220</b>	<b>PME for Skilled services:</b> Personal Medical Examination(PME) as per Factory Act for Personnel engaged for skilled Service . Shall be reimbursed on actuals after receipt of payment invoice or voucher. <b>Bidder need not quote</b>	<b>1.00</b>	<b>LS M</b>
<b>230</b>	<b>Service Charge for Insurance &amp;PME: Service Charge for Insurance and PME. Bidders shall quote upto a maximum of 3.85%</b>	<b>1.00</b>	<b>LS M</b>
<b>240</b>	<b>PPE for Skilled services:</b> Providing Safety Shoe and Raincoat to each Worker engaged under Skilled service (one pair shoe and one raincoat per year) for two years. Shall be reimbursed on receipt of actuals. <b>Bidder need not quote</b>	<b>1.00</b>	<b>LS M</b>

**E-TENDER: CGI7847P25**

	-		
<b>Total</b>	<b>Price</b>	<b>excluding</b>	<b>GST(In words)</b>
<hr/>			
<b>Total</b>	<b>Price</b>	<b>including</b>	<b>GST(In words)</b>
<hr/>			
<b>Please note that :-</b>			
<b>Offers not furnished in the above format as per instruction given shall be summarily rejected.</b>			
<b>Special Notes:</b>			

<p><b>1. The price/rate(s) quoted by the Bidders will be inclusive of all taxes except GST (i.e. IGST or CGST and SGST/UTGST as applicable in case of interstate supply or intra state supply respectively and Cess on GST , if applicable) on the final services. However, GST rate (including cess) to be provided in the respective places in the Price Bid.</b></p>			
---	--	--	--

<p><b>2. OIL will prefer to deal with registered bidder under GST. Therefore, bidders are requested to get themselves registered under GST, if not registered yet. However, in case any unregistered bidder is submitting their bid, their prices will be loaded with applicable GST while evaluation of bid.</b></p>			
<p><b>3.Price Bid uploaded without giving any of the details of the taxes (Including rates and amounts) will be considered as inclusive of all taxes including GST.</b></p>			

<p><b>4. When a bidder mentions taxes as extra without specifying the rates &amp; amount, the offer will be loaded with maximum value towards taxes received against the tender for comparison purposes. If the bidder emerges as lowest bidder after such loading, in the event of order on that bidder, taxes mentioned by OIL on the Purchase Order/ Contracts will be binding on the bidder."</b></p>			
<p><b>5. Refer GST Clauses (Clause no. 49.0 of GCC).</b></p>			

**E-TENDER: CGI7847P25**

<p><b>6. Bidders are required to quote for all the items as per Price Bid Format; otherwise the offer of the bidder will be straightway rejected.</b></p>			
<p><b>7. Bidders are also requested to refer the Taxes and Duties clause during GST regime attached vide Annexure-I (refer bid document) for compliance</b></p>			

<p><b>8. Amount of GST shall not be included by the Contractor in their quoted price. OIL will reimburse the GST to the CONTRACTOR against submission of invoices issued in accordance with GST Rules,</b></p>			
<p><b>9. Bidder shall furnish this Form duly filled in all respects along with his price part. However, Bidder is required to furnish this Form indicating only the Rate of Duty/ Tax (%) as per Column (D) along with his un-priced part.</b></p>			

**E-TENDER: CGI7847P25**

<p><b>10. The rate of GST indicated in this format shall be considered for statutory variation as per the provisions of bidding document.</b></p>			
<p><b>11. GST quoted above shall be considered for evaluation as per provisions of Bidding Document.</b></p>			

<p><b>12. Contractor shall indicate total GST amount payable under the contract in this format. However, if Services, to be provided by the Contractor, falls under the category defined under reverse charge rule of GST then the liability of deposition of GST to the tax authority by the Contractor, and by the Owner shall be dealt in accordance with Notifications issued on reverse charge rule of GST by Government of India from time to time.</b></p>			
---	--	--	--

\*\*\*\*\*

**Annexure -I**

**E-TENDER: CGI7847P25**  
**TAXES AND DUTIES CLAUSE - FOR VENDOR/SUPPLIER/CONTRACTOR**  
**(For Supplies/ Services during GST Regime i.e., New Tender)**

**INDIRECT TAXES/ GST**

1. For the purposes of levy and imposition of GST, the expressions shall have the following meanings:
  - (a) GST - means any tax imposed on the supply of goods and/or services under GST Law.
  - (b) Cess – means any applicable cess, existing or future on the supply of Goods and Services as per Goods and Services Tax (Compensation to States) Act, 2017.
  - (c) GST Law - means IGST Act 2017, CGST Act 2017, UTGST Act, 2017 and SGST Act, 2017 and all related ancillary Rules and Notifications issued in this regard from time to time.
2. **The rates quoted by the bidders shall be inclusive of all taxes, duties and levies.** However, bidders are required to provide separately the rate and amount of all types of taxes, duties and levies. In case, the quoted information related to various taxes, duties & levies subsequently proves wrong, incorrect or misleading, OIL will have no liability to reimburse the difference in the duty/ tax, if the finally assessed amount is on the higher side and OIL will have to right to recover the difference in case the rate of duty/ taxes finally assessed is on the lower side. Further, for the purpose of this contract, it is agreed between the parties that if Goods and Services Tax introduced during the tenure of this contract/agreement then the bidders have to clearly show the amount of GST separately in the Tax Invoices. Further, it is the responsibility of the bidders to make all possible efforts to make their accounting / IT system GST compliant in order to ensure availability of Input Tax Credit (ITC) to Oil India Ltd.
3. Offers without giving any of the details of the taxes (Including rates and amounts) as specified above will be considered as inclusive of all taxes including GST. When a bidder mentions taxes as extra without specifying the rates & amount, the offer will be loaded with maximum value towards taxes received against the tender for comparison purposes. If the bidder emerges as lowest bidder after such loading, in the event of order on that bidder, taxes mentioned by OIL on the Purchase Order/ Contracts will be binding on the bidder.
4. Bidders are required to pass on the benefit arising out of introduction of GST, including seamless flow of Input Tax Credit, reduction in Tax Rate on inputs as well as final goods by way of reduction of price as contemplated in the provision relating to Anti-Profitteering Measure vide Section 171 of the CGST Act, 2017. Accordingly, for supplies made under GST, the bidders should confirm that benefit of lower costs has been passed on to OIL by way of lower prices/taxes and also provide details of the same as applicable. OIL reserves the right to examine such details about costs of inputs/input services of the bidders to ensure that the intended benefits of GST have been passed on to OIL.

**E-TENDER: CGI7847P25**

5. Oil India Ltd. shall declare the value of free issue of materials and services, if any, involved in the execution of the contract. The Contractor should consider the same while working out the GST liability, if any. Further in cases where GST is leviable on any facilities provided by OIL and used by bidders and the consideration for which is recovered by OIL in the form of reduction in the invoice raised by bidders then OIL will raise GST invoices on such transactions and the same will be reimbursed by bidders.

**6. When Input tax credit is available for Set Off as per the end use certification given by User Department at the time of raising Purchase Requisition (P.R.)**

Evaluation of L-1 prices shall be done based on Quoted price after deduction of Input Tax Credit (ITC) of GST, if available to OIL. OIL shall evaluate the offers on the basis of the quoted rates only and any claim subsequently by the bidders for additional payment/liability shall not be admitted and has to be borne by the bidders

**When Input tax credit is NOT available for Set Off**

Evaluation of L-1 prices shall be done based on Quoted price only. OIL shall evaluate the offers on the basis of the quoted rates only and any claim subsequently by the bidders for additional payment/liability shall not be admitted and has to be borne by the bidders

7. In a situation where Purchase Orders (POs)/ Contracts have been placed prior to GST Regime and supplies are effected during GST Regime, it is made clear that any statutory variation (increase/decrease) due to introduction of GST, as the case may be, but within the contractual delivery/completion period will be to the account of OIL subject to documentary evidence. However, any increase in statutory levy after the expiry of the scheduled date of delivery shall be to the supplier's account.

8. Bidders agree to do all things not limited to providing GST compliant Tax Invoices or other documentation as per GST law relating to the supply of goods and/or services covered in the instant contract like raising of and /or acceptance or rejection of credit notes / debit notes as the case may be, payment of taxes, timely filing of valid statutory Returns for the tax period on the Goods and Service Tax Network (GSTN), submission of general information as and when called for by OIL in the customized format shared by OIL in order to enable OIL to update its database etc. that may be necessary to match the invoices on GSTN common portal and enable OIL to claim input tax credit in relation to any GST payable under this Contract or in respect of any supply under this Contract.

9. In case Input Tax Credit of GST is denied or demand is recovered from OIL by the Central / State Authorities on account of any non-compliance by bidders, including non-payment of GST charged and recovered, the Vendor/Supplier/Contractor shall indemnify OIL in respect of all claims of tax, penalty and/or interest, loss, damages, costs, expenses and liability that may arise due to such non-compliance. OIL, at its discretion, may also withhold/recover such disputed amount from the pending payments of the bidders.

10. GST liability, if any on account of supply of free samples against any tender shall be to bidder's account.

**E-TENDER: CGI7847P25**

**PART-5**

**OIL INDIA LIMITED  
(A Govt. of India Enterprise)  
Udyan Vihar, Narengi, Guwahati,  
Assam**

**Schedule of company's Plants, Materials and Equipments (SCPME)**

**Tender No. CGI7847P25**

**AS PER THIS TENDER**

**PAYMENT TERMS**

**TERMS OF PAYMENT: AS PER THIS TENDER**

**\*\*\*\*\***

**PART-7. SECTION-III**

**SPECIAL TERMS & CONDITIONS OF CONTRACT (SCC)**

1. All materials mentioned in various service line items are to be provided by the contractor. All materials being supplied are to be approved by OIL engineer. Only after the supplied items are acceptable by OIL, the Contractor can invoice the supply items in the next bill cycle.
2. The contractor shall provide all appropriate tools and equipment needed for all the jobs mentioned in various service line items and will ensure safety of his workers engaged in the work.
3. All work shall be completed to the satisfaction of OIL engineers.
4. Location of work mentioned may change from time to time as per OIL's requirement. The contractor shall have to provide service as per OIL's requirement all along the ROW under PS5 jurisdiction ie from Kopili river (PLKM 352) to Pathasla (PLKM 497) and PHQ to Guwahati Refinery Terminal and PHQ.
5. Contractor shall ensure that all work is carried out in accordance with the SOP and for the purpose; he may deploy adequate qualified and competent personnel for carrying out the job in a safe manner.
6. Any liabilities or compensation arising out of the job carried out by the Contractor whether related to pollution, Safety or Health will be paid by the contractor only.
7. The contractor shall have to report all incidents including near miss to OIL representative of the concerned department of OIL.
8. If the company arranges any safety class or training for the working personnel at site (company employee, contractor worker, etc) the contractor shall not have any objection to any such training.
9. A contractor employee must, while at work, take reasonable care for the health and safety of people who are at the employee's place of work and who may be affected by the employee's act or omissions at work.
10. A contractor employee must, while at work, cooperate with his or her employer or other persons so far as is necessary to enable compliance with any requirement under the act or the regulations that is imposed in the interest of health, safety and welfare of the employee or any other person.
11. The contractor should prevent the frequent change of his contractual employees as far as practicable.

**E-TENDER: CGI7847P25**

12. The skilled & unskilled workers shall work under supervision of authorized technicians/Supervisors of Telecom & Instrumentation Dept, Pump Station-5 PHQ, OIL INDIA LIMITED and shall carry out their instructions.

13. All the services engaged under this contract shall be for maintaining OFC cable and all Telecom & Instrumentation related jobs as advised by the Telecom & Instrumentation Engineer/Telecom-in Charge.

14. The Contractor shall ensure that all the manpower services provided by him are physically fit to meet the Contract objectives. In case of any pre-existing disease or illness of any workers provided by the contractor, he shall inform the Competent Person or Section In-Charge in writing, prior to commencement of any work.

15. All the skilled and unskilled workers engaged by the contractor shall be covered only under Workmen Compensation Insurance Policy throughout the contract period.

16. In case of any contradiction between the General Conditions of Contract (GCC) and Special Terms and conditions, the special terms and conditions will prevail.

17. The payment will be made on actual consumption of the quantities of the line-item.

18. For any clarification regarding the above, the contractor may contact concerned Engineer.

19. Contractor shall engage adult personnel only.

20. No other insurances other than Workmen Compensation Insurance are applicable for this contract.

21. The Contractor shall deposit the PF of the Skilled services every month and provide the PF submission receipt with every month's invoice.

22. The Contractor shall carryout the Periodic Medical Examination (PME) of the skilled services once in every year. The PME examinations shall be governed by Factories Act and as advised by Medical Officer of OIL.

23. The contractor shall provide the requisite quantity of items as specified in the line items on as and when required basis more than once till all the quantities are exhausted as advised by OIL.

24. The contractor shall upload his /her invoices upload in OIL's VIM portal only after the measurement sheet for the invoice is verified and signed by OIL employees or engineers. The signed measurement sheet shall also be uploaded along with the invoice along with other supporting documents.

25. The contractor shall raise only a single invoice in a month. Any item left to be raised in a particular month invoice shall be included in the succeeding month invoice.

**E-TENDER: CGI7847P25**

26. The payment for skilled services for 2 nos out of 4 shall start with the commencement of the contract and other 2 nos. skilled services payment shall start from 01.09.2025 (ie. after expiry of the contract no 6117598 ).

27. The skilled services deployed by the contractor shall be well conversant with the Right of Way (ROW) of OIL from River Kopili (PLKM 352) to Pathsala (PLKM 497). The personnel deployed under this contract shall know all the existing OFC chambers, critical maintenance hot spots and route to access such locations. The skilled services personnel shall be able to use OTDR, Splicing machine, Optical Power Meter and Optical Power Measurement device . The personnel deployed under this contract shall also know the and be well conversant with OIL Telephone and IT LAN network at PHQ and are able to perform LAN and Telephone connectivity maintenance. The personnel under skilled services shall be able to perform Optical link analysis and restore any optical link fault and other IT related jobs own its own without any help from OIL.

28. In case, the contractual personnel deployed under this contract is not found to be suitable as per OIL's assessment for Slno 27. above , the contractor shall provide a suitable replacement without any objection and without any additional cost to OIL.

**GENERAL :**

a) Special Conditions of Contract (SCC) shall be read in conjunction with the General Conditions of Contract (GCC), Specifications of Work, Drawings and other documents forming part of this contract wherever the context so requires.

b) Notwithstanding the sub-division of the documents into these separate parts and volumes, every part of each shall be deemed to be supplementary to and complementary of every other part and shall be read with and into the contract in so far as it may be practicable to do so.

c) Where any portion of the GCC is repugnant to or at variance with any provision of the SCC, then the provision of the SCC shall be deemed to override the provisions of the GCC and shall, to the extent of such repugnance or variations, prevail.

d) Wherever it is mentioned in the specifications that the contractor shall perform certain works or provide certain facilities, it is to be understood that in addition to the items supplied by the company, the contractor shall do so at his own cost, being deemed to be part of the relevant item in the schedule of rates (SOR) whether specifically stated or not.

e) The design and workmanship of all materials to be used / supplied by the bidder shall satisfy the relevant Standards & Codes, besides the specifications & stipulations contained herein the contract specifications. The bidder shall absorb all cost because of the additional involvements thereon.

f) The materials, design, and workmanship shall satisfy the relevant Indian Standards, the Job Specifications contained herein and Codes referred to. Where the job specification stipulate requirements in addition to those contained in the standard codes and specifications, these additional requirements shall also be satisfied.

g) In case of an irreconcilable conflict between Indian or other applicable standards, General Conditions of Contract, Special Conditions of Contract, Scope of

**E-TENDER: CGI7847P25**

Work or Schedule of Rates, the following shall prevail to the extent of such irreconcilable conflict in order of precedence:

- i) Contract Agreement
- ii) Detailed Letter of Acceptance along with Statement of Agreed Variations.
- iii) Fax / Letter of Intent / Fax of Acceptance.
- iv) Schedule of Rates as enclosures to Detailed Letter of Acceptance.
- v) Scope of Work.
- vi) Special Conditions of Contract.
- vii) Instruction to Bidders
- viii) General Conditions of Contract.
- ix) Indian Standards
- x) Other applicable Standards
- xi) A variation or amendment issued after the execution of the formal contract shall take precedence over respective clauses of the formal contract and its Annexures.

\*\*\*\*\*

**E-TENDER: CGI7847P25**

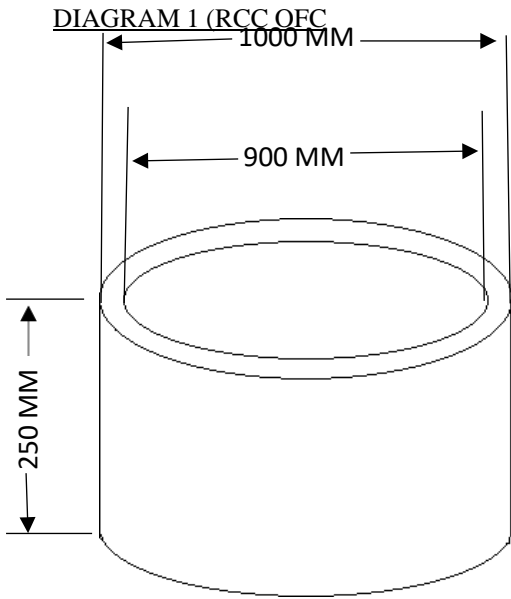

**RCC RING**

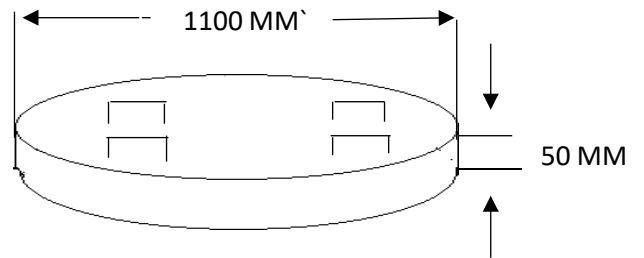

**BOTTOM COVER**

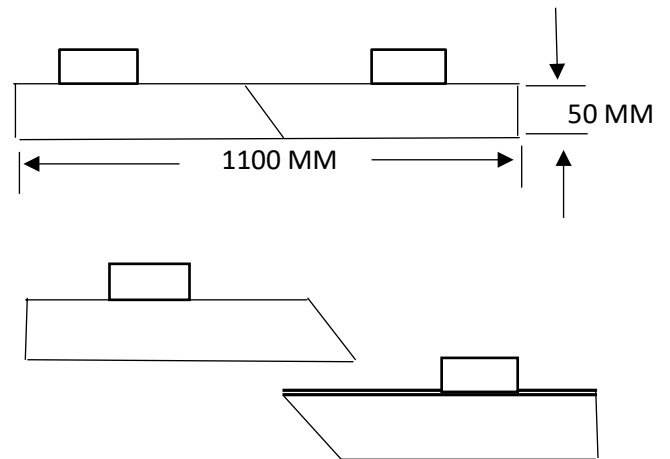

**SIDE VIEW OF BOTTOM COVER & TOP COVER**

**E-TENDER: CGI7847P25**

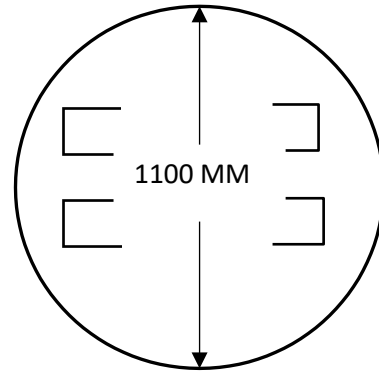
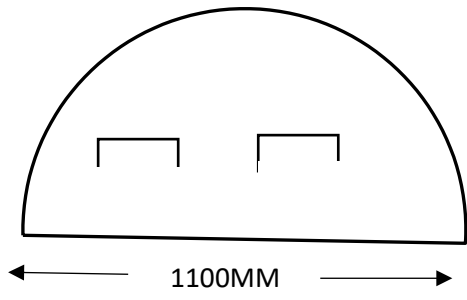

**TOP VIEW TOP COVER & BOTTOM COVER**

DIAGRAM 2

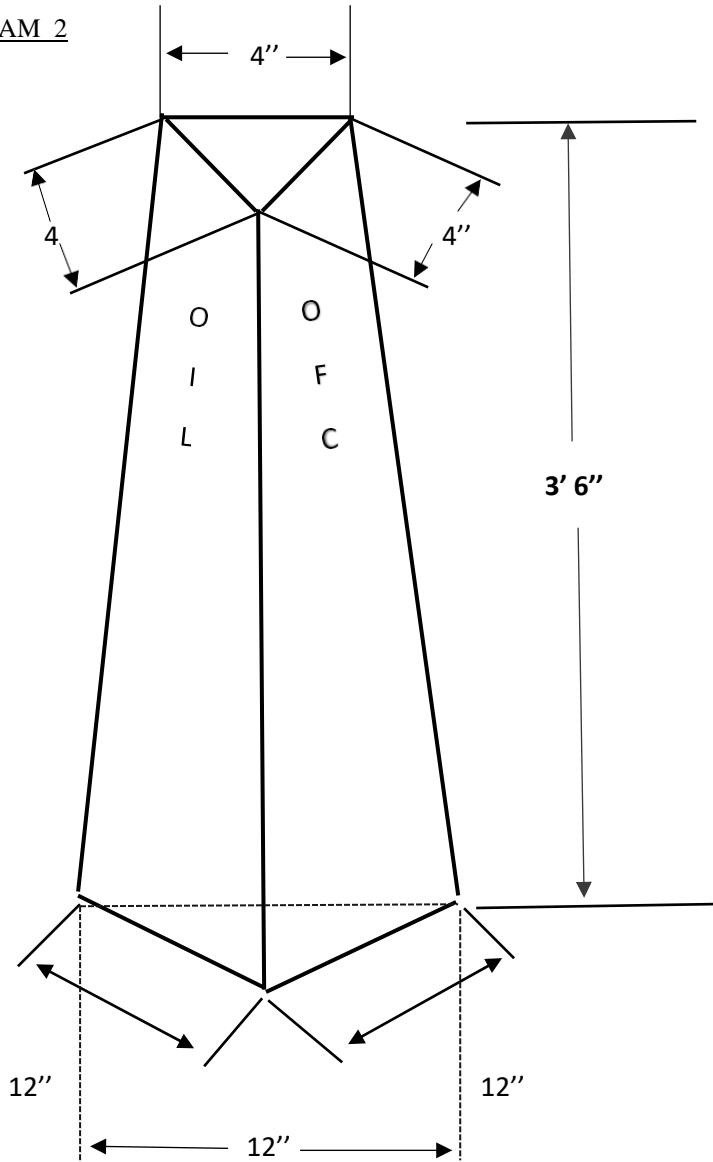

**Concrete proportion 1:2:4**

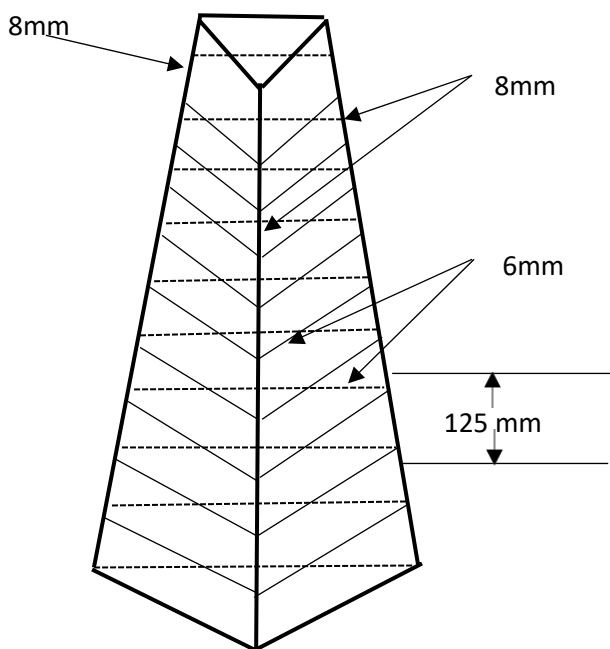

**Reinforcement details**

**PROFORMA-A**

**PRICE SCHEDULE FORMAT**

**AS PER PART-4, SECTION-II**

\*\*\*\*\*  

---

**PROFORMA-B**

**BID FORM**

To  
THE GM (C&P)  
OIL INDIA LIMITED  
(A Govt. of India Enterprise)  
P.O. GUWAHATI-781171  
DIST. KAMRUP(M)  
ASSAM

Sub: IFB No.: **CGI7847P25**

Dear Sir,

Having examined the General and Special Conditions of Contract and the Terms of Reference including all attachments thereto, the receipt of which is hereby duly acknowledged, we the undersigned offer to perform the services in conformity with the said conditions of Contract and Terms of Reference for the sum of \_\_\_\_ (Price not to be indicated)\_\_\_\_ stated below or such other sums as may be ascertained in accordance with the Price Bid Form attached herewith and made part of this Bid:

We undertake, if our Bid is accepted, to commence the work within (\_\_\_\_) days calculated from the date of issue of Company's LOA.

We agree to abide by this Bid for a period of **90 days** from the date fixed for Bid opening and it shall remain binding upon us and may be accepted at any time before the expiration of that period.

Until a formal Contract is prepared and executed, this Bid, together with your written acceptance thereof in your notification of award shall constitute a binding Contract between us.

We understand that you are not bound to accept the lowest or any Bid you may receive.

Dated this \_\_\_\_\_ day of \_\_\_\_\_ 2022.

Signature and seal of the Bidder: \_\_\_\_\_

(In the capacity of) : \_\_\_\_\_

Name of Bidder : \_\_\_\_\_

\*\*\*\*\*  
\_\_\_\_\_

**PROFORMA - C**

**STATEMENT OF NON-COMPLIANCE**

**(Only exceptions/deviations to be rendered)**

1.0 The Bidder shall furnish detailed statement of **exceptions/deviations**, if any, to the tender stipulations, terms and conditions in respect of each PART of Bid Document in the following format:

<b>PART No.</b>	<b>Clause No. (Page No.)</b>	<b>Non-Compliance</b>	<b>Remarks</b>

**Authorised Person's Signature:** \_\_\_\_\_

**Name:** \_\_\_\_\_

**Designation:** \_\_\_\_\_

**Seal of the Bidder:**

**NOTE:** OIL INDIA LIMITED expects the bidders to fully accept the terms and conditions of the bid document. However, should the bidders still envisage some exceptions/deviations to the terms and conditions of the bid document, the same should be indicated as per above format and submit along with their bids.

If the "**Statement of Compliance**" in the above Proforma is left blank (or not submitted along with the technical bid), then it would be construed that the bidder has not taken any exception/deviation to the tender requirements.

\*\*\*\*\*  
\_\_\_\_\_

**PROFORMA-D**

**FORM OF BID SECURITY (BANK GUARANTEE FORMAT)**

**( APPLICABLE FOR THIS TENDER)**

To  
M/s. OIL INDIA LIMITED,  
CONTRACTS DEPARTMENT,  
OIL INDIA LIMITED  
PIPELINE HEADQUARTERS  
GUWAHATI, ASSAM, INDIA, PIN - 781171.

WHEREAS, \_\_\_\_\_(Name of Bidder)  
(hereinafter called "the Bidder") has submitted their offer Dated \_\_\_\_\_ for  
the provision of certain services (hereinafter called "the Bid") against OIL INDIA  
LIMITED, Duliajan, Assam, India (hereinafter called the Company)'s Tender  
No. \_\_\_\_\_ KNOW ALL MEN BY these presents that we \_\_\_\_\_  
(Name of Bank) of \_\_\_\_\_(Name of Country) having our registered office  
at \_\_\_\_\_(hereinafter called "Bank") are bound unto the Company in the  
sum of (\* ) for which payment well and truly to be made to Company, the Bank  
binds itself, its successors and assignees by these presents.  
SEALED with the said Bank this \_\_\_\_\_day of \_\_\_\_\_20\_\_.

THE CONDITIONS of these obligations are:

1. If the Bidder withdraws their Bid within its original/extended validity; or
2. The Bidder modifies/revises their bid suo moto; or
3. The Bidder does not accept the contract; or
4. The Bidder does not furnish Performance Security Deposit within the stipulated time as per tender/contract; or
5. If it is established that the Bidder has submitted fraudulent documents or has indulged into corrupt and fraudulent practice.

We undertake to pay to Company up to the above amount upon receipt of its first written demand (by way of letter/fax/cable), without Company having to substantiate its demand provided that in its demand Company will note that the amount claimed by it is due to it owing to the occurrence of any of the conditions, specifying the occurred condition or conditions.

This guarantee will remain in force up to and including the date (\*\*--/--/--) and any demand in respect thereof should reach the Bank not later than the above date.

The details of the Issuing Bank and Controlling Bank are as under:

A. Issuing Bank:  
BANK FAX NO:  
BANK EMAIL ID:  
BANK TELEPHONE NO.:  
IFSC CODE OF THE BANK:

B. Controlling Office:

Address of the Controlling Office of the BG issuing Bank:

Name of the Contract Person at the Controlling Office with Mobile No. and e-mail address:

Notwithstanding anything contained herein:

- a) Our liability under this Bank Guarantee shall is restricted up to Rs.....
- b) This guarantee shall be valid till .....
- c) We are liable to pay the guaranteed amount or any part thereof under this Bank Guarantee only and only if you serve upon us a written claim or demand on or before ..... (Date of Expiry of BG PLUS one year claim period).
- d) At the end of the claim period that is on or after ..... (Date of expiry of the Bank Guarantee Plus Minimum of 1 year claim period shall be stipulated) all your rights under this Guarantee shall stand extinguished and we shall be discharged from all our liabilities under this Guarantee irrespective of receipt of original Bank Guarantee duly discharged, by Bank.

Name of the Contact Person at the Controlling Office with Mobile No. and e-mail address:

- a) SIGNATURE AND SEAL OF THE GUARANTORS \_\_\_\_\_
- b) Designation \_\_\_\_\_
- c) Name of the Bank \_\_\_\_\_
- d) Address \_\_\_\_\_

Note:

\* The Bidder should insert the amount of the guarantee in words and figures.

\*\* Date of expiry of Bank Guarantee should be minimum 30 days after the end of the validity period of the Bid / as specified in the Tender.

\*\*\* The Bank Guarantee issuing bank branch must ensure the following:

a. The Bank Guarantee issued by the bank must be routed through SFMS platform as per the following details:

- (i) MT 760/MT 760 COV for issuance of bank guarantee.
- (ii) MT 760/MT 767 COV for amendment of bank guarantee.

[Tender Number should reflect in the SFMS text under MT 760/MT 760 COV]  
The above message / intimation shall be sent through SFMS by the BG issuing Bank branch to Axis Bank, Guwahati Branch, IFS Code- UTIB0000140, Branch Address – Axis Bank Ltd, Guwahati Branch, Chibber House, G S Road, Dispur, Assam, PIN- 781005..

b. Bank Guarantee issued by a Scheduled Bank in India at the request of some other Non-Scheduled Bank of India shall not be acceptable.

c. Further correspondence against BG towards Bid Security must contain the Tender Number.

**PROFORMA-E**

**FORM OF PERFORMANCE BANK GUARANTEE**

(To be submitted by the successful bidder in case of award of contract)

To:

M/s. OIL INDIA LIMITED,  
CONTRACTS DEPARTMENT  
PIPELINE DEPARTMENT, GUWAHATI  
ASSAM, INDIA, PIN -781 171.

WHEREAS \_\_\_\_\_ (Name and address of Contractor) (hereinafter called "Contractor") had undertaken, in pursuance of Contract No. \_\_\_\_\_ to execute (Name of Contract and Brief Description of the Work) \_\_\_\_\_ (hereinafter called "the Contract").

AND WHEREAS it has been stipulated by you in the said Contract that the Contractor shall furnish you with a Bank Guarantee as security for compliance with Contractor's obligations in accordance with the Contract.

AND WHEREAS we have agreed to give the Contractor such a Bank Guarantee; NOW THEREFORE we hereby affirm that we are Guarantors on behalf of the Contractor, up to a total of (Amount of Guarantee in figures) \_\_\_\_\_ (in words \_\_\_\_\_), such amount being payable in the types and proportions of currencies in which the Contract price is payable, and we undertake to pay you, upon your first written demand and without cavil or argument, any sum or sums within the limits of guarantee sum as aforesaid without your needing to prove or to show grounds or reasons for your demand for the sum specified therein. We hereby waive the necessity of your demanding the said debt from the Contractor before presenting us with the demand.

We further agree that no change or addition to or other modification of the terms of the Contract or the work to be performed thereunder or of any of the Contract documents which may be made between you and the Contractor shall in any way cease us from any liability under this guarantee, and we hereby waive notice of such change, addition or modification.

This guarantee is valid until the -----day of -----

The details of the Issuing Bank and Controlling Bank are as under:

A. Issuing Bank:

BANK FAX NO:

BANK EMAIL ID:

BANK TELEPHONE NO.:

IFSC CODE OF THE BANK:

B. Controlling Office:

Address of the Controlling Office of the BG issuing Bank:

Name of the Contact Person at the Controlling Office with Mobile No. and e-mail address:

SIGNATURE AND SEAL OF THE GUARANTORS \_\_\_\_\_

Designation \_\_\_\_\_

Name of Bank \_\_\_\_\_

Address \_\_\_\_\_

Witness \_\_\_\_\_

Address \_\_\_\_\_

\_\_\_\_\_

Date \_\_\_\_\_

Place \_\_\_\_\_

**Note: Bank details of Oil India Limited may be required by Bank for issuance of Bank Guarantee (BG):**

<b>BANK DETAILS OF BENEFICIARY</b>		
<b>a</b>	Bank Name	AXIS BANK
<b>b</b>	Branch Name	GUWAHATI
<b>c</b>	Branch Address	CHIMBER HOUSE, G.S.ROAD, DISPUR ASSAM
<b>d</b>	Banker Account No.	140010200027654
<b>e</b>	Type of Account	CURRENT ACCOUNT
<b>f</b>	IFSC Code	UTIB0000140
<b>g</b>	MICR Code	781211002
<b>h</b>	SWIFT Code	Axisinbb140
<b>i</b>	Contact No.	8876501401
<b>j</b>	Contact Person Name	Mr. Dibakar Ghaosh
<b>k</b>	Fax No.	Not available
<b>l</b>	Email Id	<a href="mailto:Guwahati.branchhead@axisbank.com">Guwahati.branchhead@axisbank.com</a>

\*\*\*\*\*

**DRAFT AGREEMENT COPY**  
**(To be executed by the successful Bidder)**

This AGREEMENT is made on the ..... day of .....

**BETWEEN**

OIL INDIA LIMITED, a Government of India Enterprise, incorporated under the Companies Act 1956, having its registered office at Duliajan in the state of Assam, hereinafter called the “**COMPANY**” which expression unless repugnant to the context shall include executors, administrators and assignees on one part

**AND**

M/s. ...., having its address ..... hereinafter called the “**CONTRACTOR**” or “**Transport Supplier:**” which term shall unless excluded by or repugnant to the subject or context include its successors and permitted assignees, on the other part,

**WHEREAS**

OIL INDIA LIMITED being desirous of awarding a comprehensive contract for **“Maintenance of OFC cable and other Telecom activities for a period of two years extendable by another one year upon review under PS5 Sector(ROW Chainage PLKM 352-497 & Spur Line PHQ - GHY Refinery Termianl)”**

- A. M/s. ...., have examined the nature and magnitude of the service to be provided and have satisfied themselves by careful examination before quoting their rates as to the nature and magnitude of the services to be provided, local conditions, the availability of manpower and resources necessary for rendering the service and have made local and independent enquiries and obtained complete information and have examined and considered all other issues, conditions and things and probable and possible contingencies, and generally all matters incidental thereto and auxiliary thereof affecting the services and have included them while making their offer.

**WHEREAS**, Company, (OIL INDIA LIMITED) having accepted the offer of the Contractor and (subsequent letter dated \_\_\_\_\_), issued the “Letter of Award” under reference \_\_\_\_\_ dated \_\_\_\_\_.

**Whereas**, the Contractor has accepted Company’s Letter of Award vide their letter \_\_\_\_\_

NOW IN CONSIDERATION OF THE MUTUAL COVENANTS AND AGREEMENTS HEREINAFTER CONTAINED IT IS HEREBY AGREED AS FOLLOWS:

- i) In this Agreement words and expressions shall have the same meanings as are respectively assigned to them in the General Conditions of Contract referred to.
- ii) The following documents shall be deemed to form and be read and construed as part of this agreement viz:

**E-TENDER: CGI7847P25**

- (a) The Tender Document No.....dated ....., inter-alia providing the Instruction to the bidder ,General Conditions of Contract, Scope of Work / terms of reference /Technical specifications etc., Special conditions of contract.
- (b) The Bid submitted by the Contractor in response to the Tender enquiry,
- (c) The contractors letter dated ..... ( after price negotiation) if any .
- (d) The Company's Notification of Award vide Letter of Award No. \_\_\_\_\_ dated \_\_\_\_\_.
- (e) Section-I, II, III & IV hereto.
- (f) Annexure -I hereto
- iii) The rates payable for the job will be as indicated in **Part-4**
- iv) In consideration of the payment to be made by the Company to the Contractor for carrying out the assigned service , the Contractor hereby covenants with the Company that the Contractor shall and will carry out the assigned service and complete the said service and shall do and perform all other acts and things mentioned in the Agreement or described or which are to be implied there from or may be reasonably necessary for the execution of the said assignment in the desired manner and time and subject to the terms and conditions or stipulations mentioned in the Agreement.
- v) The Company hereby covenants to pay the Contractor in consideration of the due provision, execution and completion of the services and the remedying of defects therein , the contract price or such other sum as may become payable under the provisions of this contract at times and in manner prescribed in this contract.

IN WITNESS thereof, the parties have executed this contract on the day and the year first above mentioned at the office of the **General Manager(C&P)**, Pipelines, Pipeline Head Quarter, Narengi, Guwahati, Assam.

Signed and Delivered for and  
and  
On behalf of Company

Signed and Delivered for  
  
on behalf of Contractor

(Oil India Limited)

( )

IN PRESENCE OF TWO WITNESSES :  
WITNESSES

IN PRESENCE OF TWO

1.  
2.

1.

2.

**PROFORMA – G**  
**LETTER OF AUTHORITY**

To  
THE GM (C&P)  
OIL INDIA LIMITED  
(A Govt. of India Enterprise)  
P.O. GUWAHATI-781171  
DIST. KAMRUP(M)  
ASSAM

Sir,

Sub: IFB No. **CGI7847P25**

We \_\_\_\_\_ confirm that Mr. \_\_\_\_\_  
(Name and address) as authorized to represent us to Bid, negotiate and conclude  
the agreement on our behalf with you against Invitation  
No.: \_\_\_\_\_ for the service contract as described below:

**“Maintenance of OFC cable and other Telecom activities for a period of two  
years extendable by another one year upon review under PS5 Sector(ROW  
Chainage PLKM 352-497 & Spur Line PHQ - GHY Refinery Termianl)”.**

We confirm that we shall be bound by all and whatsoever our said representative  
shall commit.

Yours Faithfully,

Signature: \_\_\_\_\_

Name : \_\_\_\_\_

Designation: \_\_\_\_\_

For & on behalf of: \_\_\_\_\_

Note: This letter of authority shall be printed on letter head of the Bidder and  
shall be signed by a competent person to bind the Bidder.

\*\*\*\*\*

**AUTHORISATION FOR ATTENDING BID OPENING**

TO,  
**GM (C&P)**  
Oil India Ltd.,  
P.O. Udayan Vihar,  
Guwahati - 781171  
Assam, India

Date:

\_\_\_\_\_  
Sir,

**Sub: OIL's IFB No. CGI7847P25**

We authorise Mr. /Mrs. \_\_\_\_\_ (Name and address) to be present at the time of opening of the above IFB due on \_\_\_\_\_ at Guwahati on our behalf.

Yours Faithfully,

**Authorised Person's Signature:** \_\_\_\_\_

**Name:** \_\_\_\_\_

**Designation:** \_\_\_\_\_

**Seal of the Bidder:**

**Note:** This letter of authority shall be on printed letter head of the Bidder and shall be signed by a person who signs the bid.

.....

**INTEGRITY PACT( APPLICABLE FOR THIS TENDER)**

**INTEGRITY PACT**

Between

Oil India Limited (OIL) hereinafter referred to as "The Principal"

And

(Name of the bidder).....hereinafter referred to as  
"The Bidder"

**Preamble:**

The Principal intends to award, under laid down organizational procedures, contract/s for ----- . The Principal values full compliance with all relevant laws and regulations, and the principles of economic use of resources, and of fairness and transparency in its relations with its Bidder/s.

In order to achieve these goals, the Principal cooperates with the renowned international Non-Governmental Organization "Transparency International" (TI). Following TI's national and international experience, the Principal will appoint an external independent Monitor who will monitor the tender process for compliance with the principles mentioned above.

**Section: 1 -Commitments of the Principal**

**(1)** The Principal commits itself to take all measures necessary to prevent corruption and to observe the following principles:

- (i) No employee of the Principal, personally or through family members, will in connection with the tender for, or during execution of a contract, demand, take a promise for or accept, for him/herself or third person, any material or immaterial benefit which he/she is not legally entitled to.
- (ii) The Principal will, during the tender process treat all Bidders with equity and reason. The Principal will in particular, before and during the tender process, provide to all Bidders the same information and will not provide to any Bidder confidential/additional information through which the Bidder could obtain an advantage in relation to the tender process.
- (iii) The Principal will exclude from the process all known prejudiced persons.

**(2)** If the Principal obtains information on the conduct of any of its employees which is a criminal offence under the relevant Anti-Corruption Laws of India, or if there

be a substantive suspicion in this regard, the Principal will inform the Chief Vigilance Officers and in addition can initiate disciplinary actions.

**Section: 2 -Commitments of the Bidder/Contractor**

**(1)** The Bidder commits itself to take all measures necessary to prevent corruption. During his participation in the tender process, the Bidder commits himself to observe the following principles:

- (i) The Bidder will not, directly or through any other person or firm, offer, promise or give to any of the Principal's employees involved in the tender process or the execution of the contract or to any third person any material or immaterial benefit which he/she is not legally entitled to, in order to obtain in exchange any advantage of any kind whatsoever during the tender process or during subsequent contract execution, if awarded.
- (ii) The Bidder will not enter with other Bidders into any undisclosed agreement or understanding, whether formal or informal. This applies in particular to prices, specifications, certifications, Subsidiary contracts, submission or non-submission of bids or any other actions to restrict competitiveness or to introduce cartelization in the bidding process.
- (iii) The Bidder(s) will not commit any offence under the relevant Anticorruption Laws of India, further, the Bidder(s) will not use improperly, for purposes of competition or personal gain, or pass on to others, any information or document provided by the Principal as part of the business relationship, regarding plans, technical proposals and business details, including information contained or transmitted electronically.
- (iv) The Bidder will, when presenting his bid, disclose any and all payments he has made, is committed to or intends to make to agents, brokers or any other intermediaries in connection with the award of the contract.
- (v) Bidders to disclose any transgressions with any other public/government organization that may impinge on the anti-corruption principle. The date of such transgression, for the purpose of disclosure by the bidders in this regard, would be the date on which cognizance of the said transgression was taken by the competent authority. The period for which such transgressions (s) is/are to be reported by the bidders shall be the last **three years** to be reckoned from date of bid submission. The transgression (s), for which cognizance was taken even before the said period of three years, but are pending conclusion, shall also be reported by the bidders.
- (vi) The Bidder(s) of foreign origin shall disclose the name and address of the Agents/ representatives in India, if any. Similarly, the Bidder(s) of Indian Nationality shall furnish the name and address of the foreign principals, if any. Further, all the payments made to the Indian agent/ representative have to be in India Rupees only.

- (vii) Bidders not to pass any information provided by Principal as part of business relationship to others and not to commit any offence under PC/ IPC Act;
- (2) The Bidder will not instigate third persons to commit offences outlined above or be an accessory to such offences.
- (3) The Bidder signing Integrity Pact shall not approach the Courts while representing the matters to IEMs and he/she will await their decision in the matter.

**Section 3 -Disqualification from tender process and exclusion from future Contracts**

If the Bidder, before contract award has committed a transgression through a violation of Section 2 or in any other form such as to put his reliability or risibility as Bidder into question, the Principal is entitled to disqualify the Bidder from the tender process, for such reason.

1. If the Bidder has committed a transgression through a violation of Section 2 such as to put his reliability or credibility into question, the Principal is entitled also to exclude the Bidder from future contract award processes. The imposition and duration of the exclusion will be determined by the severity of the transgression. The severity will be determined by the circumstances of the case, in particular the number of transgressions, the position of the transgressions within the company hierarchy of the Bidder and the amount of the damage. The exclusion will be imposed for a minimum of 6 months and maximum of 2 years.
2. The Bidder accepts and undertakes to respect and uphold the Principal's Absolute right to resort to and impose such exclusion and further accepts and undertakes not to challenge or question such exclusion on any ground, including the lack of any hearing before the decision to resort to such exclusion is taken. This undertaking is given freely and after obtaining independent legal advice.
3. If the Bidder can prove that he has restored/recouped the Damage caused by him and has installed a suitable corruption prevention system, the Principal may revoke the exclusion prematurely.
4. A transgression is considered to have occurred if in light of available evidence, no reasonable doubt is possible.
5. Integrity Pact, in respect of a particular contract, shall be operative from the date Integrity Pact is signed by both the parties or as mentioned in Section 9 - Pact Duration whichever is later. Any violation of the same would entail disqualification of the bidders and exclusion from future business dealings.

**Section 4 -Compensation for Damages**

## **E-TENDER: CGI7847P25**

(1) If the Principal has disqualified the Bidder from the tender process prior to the award according to Section 3, the Principal is entitled to demand and recover from the Bidder liquidated damages equivalent to Earnest Money Deposit / Bid Security(if applicable).

(2) The bidder agrees and undertakes to pay the said amounts without protest or demur subject only to condition that if the Bidder can prove and establish that the exclusion of the Bidder from the tender process has caused no damage or less damage than the amount or the liquidated damages, the Bidder shall compensate the Principal only to the extent of the damage in the amount proved.

### **Section 5 -Previous transgression**

(1) The Bidder declares that no previous transgression occurred in the last 3 years with any other company in any country conforming to the TI approach or with any other Public Sector Enterprise in India that could justify his exclusion from the tender process.

(2) If the Bidder makes incorrect statement on this subject, he can be disqualified from the tender process for such reason.

### **Section: 6 -Equal treatment of all Bidders/Contractor/Subcontractors**

(1) The Principal will enter into Pacts on identical terms with all bidders.

(2) The Bidder undertake(s) to procure from all subcontractors a commitment in conformity with this Integrity Pact. The Bidder shall be responsible for any violation(s) of the provisions laid down in this agreement/Pact by any of its subcontractors/sub-vendors.

(3) The Principal will disqualify from the tender process all bidders who do not sign this Pact or violate its provisions.

### **Section: 7 -Criminal charges against violating Bidders/Contractors/Subcontractors**

If the Principal obtains knowledge of conduct of a Bidder, Contractor or Subcontractor, or of an employee or a representative or an associate of a Bidder, Contractor or Subcontractor, which constitutes corruption, or if the Principal has substantive suspicion in this regard, the Principal will inform the Vigilance Office.

### **Section: 8 -External Independent Monitor/Monitors**

(1) The Principal appoints competent and credible Independent External Monitor (IEM) for this Pact.

(2) The Monitor is not subject to instructions by the representatives of the parties and performs his functions neutrally and independently. He reports to the Chairperson of the Board of the Principal.

(3) The Bidder accepts that the Monitor has the right to access without restriction to all Project documentation of the Principal including that provided by the Bidder. The Bidder will also grant the Monitor, upon his request and demonstration of a valid interest, unrestricted and unconditional access to his project documentation.

The same is applicable to Subcontractors. The Monitor is under contractual obligation to treat the information and documents of the Bidder/Contractor/Subcontractor with confidentiality.

**(4)** The Principal will provide to the Monitor sufficient information about all meetings among the parties related to the Project provided such meetings could have an impact on the contractual relations between the Principal and the Bidder. The parties offer the Monitor the option to participate in such meetings.

**(5)** As soon as the Monitor notices, or believes to notice, a violation of this agreement, he will so inform the Management of the Principal and request the Management to discontinue or heal the violation, or to take other relevant action. The monitor can in this regard submit non-binding recommendations. Beyond this, the Monitor has no right to demand from the parties that they act in a specific manner, refrain from action or tolerate action. However, the Independent External Monitor shall give an opportunity to the bidder to present its case before making its recommendations to the Principal.

**(6)** The Monitor will submit a written report to the Chairperson of the Board of the Principal within 8 to 10 weeks from the date of reference or intimation to him by the 'Principal' and, should the occasion arise, submit proposals for correcting problematic situations.

**(7)** If the Monitor has reported to the Chairperson of the Board a Substantiated suspicion of an offence under relevant Anti-Corruption Laws of India, and the Chairperson has not, within reasonable time, taken visible action to proceed against such offence or reported it to the Vigilance Office, the Monitor may also transmit this information directly to the Central Vigilance Commissioner, Government of India.

**(8)** The word 'Monitor' would include both singular and plural.

**(9)** In case of any complaints referred under IP Program, the role of IEMs is advisory and the advice of IEM is non-binding on the Organization. However, as IEMs are invariably persons with rich experience who have retired as senior functionaries of the government, their advice would help in proper implementation of the IP.

### **Section:9 -Pact Duration**

This Pact begins when both parties have legally signed it. It expires for the Contractor 12 months after the last payment under the respective contract, and for all other Bidders 6 months after the contract has been awarded.

If any claim is made/ lodged during this time, the same shall be binding and continue to be valid despite the lapse of this pact as specified above, unless it is discharged/determined by Chairperson of the Principal.

### **Section:10 -Other provisions**

**(1)** This agreement is subject to Indian Law. Place of performance and jurisdiction is the Registered Office of the Principal. The Arbitration clause provided in the main tender document / contract shall not be applicable for any issue / dispute arising under Integrity Pact.

**(2)** Changes and supplements as well as termination notices need to be made in writing. Side agreements have not been made.

**(3)** In case of a joint venture, all the partners of the joint venture should sign the Integrity Pact. In case of sub-contracting, the principal contractor shall take the responsibility of the adoption of IP by the sub-contractor. It is to be ensured that all sub-contractors also sign the IP. In case of sub-contractors, the IP will be a tri-partite arrangement to be signed by the Organization, the contractor, and the sub-contractor.

**(4)** Should one or several provisions of this agreement turn out to be invalid, the remainder of this agreement remains valid. In this case, the parties will strive to come to an agreement to their original intentions.

..... <b>For the Principal</b>  Date :  Place :	..... <b>For the Bidder/Contractor</b>  Witness 1: .....  Witness 2: .....
--	---

\*\*\*\*\*

**PROFORMA-J**

**SAFETY MEASURES**

**To,  
GM(C&P)  
OIL INDIA LIMITED  
Guwahati-781171**

**Description of work/service: “ Maintenance of OFC cable and other Telecom activities for a period of two years extendable by another one year upon review under PS5 Sector(ROW Chainage PLKM 352-497 & Spur Line PHQ - GHY Refinery Termianl)”**

Sir,

We hereby confirm that we have fully understood the safety measures to be adopted during execution of the above contract and that the same have been explained to us by the concerned authorities. We also give the following assurances.

- a) Only experienced and competent persons shall be engaged by us for carrying out work under the said contract.
- b) The names of the authorized persons who would be supervising the jobs on day to day basis from our end are the following:
  - i) \_\_\_\_\_
  - ii) \_\_\_\_\_
  - iii) \_\_\_\_\_

The above personnel are fully familiar with the nature of jobs assigned and safety precautions required.

- c) Due notice would be given for any change of personnel under item(b) above.
- d) We hereby accept the responsibility for the safety of all the personnel engaged by us and for the safety of the Company's personnel and property involved during the course of our working under this contract. Any violation pointed out by the Company's engineers would be rectified forthwith or the work suspended till such time the rectification is completed by us and all expenditure towards this would be on our account.
- e) All losses caused due to inadequate safety measures or lack of supervision on our part would be fully compensated by us and the Company will not be responsible for any lapses on our part in this regard.

(Seal)

Yours Faithfully

Date\_\_\_\_\_

M/s\_\_\_\_\_

FOR & ON BEHALF OF BIDDER

\*\*\*\*\*  
\_\_\_\_\_

**(NOT APPLICABLE FOR THIS TENDER)**

**UNDERTAKING TOWARDS PURCHASE PREFERENCE**

**TO**  
**GM(C&P)**  
**Contracts Department**  
**PHQ GUWAHATI**  
**PIN-781171**  
**Dist. KAMRUP (M), Assam India**

Dear Sir,

We \_\_\_\_\_(name of the bidder) have submitted bid no. \_\_\_\_\_ against Bid no. \_\_\_\_\_date)\_\_\_\_\_

for **“Maintenance of OFC cable and other Telecom activities for a period of two years extendable by another one year upon review under PS5 Sector(ROW Chainage PLKM 352-497 & Spur Line PHQ - GHY Refinery Termianl)”**.

We are eligible and shall avail benefit of Purchase Preference under the policy,

(please (✓) tick the policy you have opted)

<b>Policy</b>	<b>Response</b>
<b>PP MSE</b>	
<b>PP LC</b>	

Yours faithfully,

Signature:  
Name & Designation:

For & on behalf of \_\_\_\_\_

**UNDERTAKING FOR LOCAL CONTENT (NOT APPLICABLE FOR THIS TENDER)**

**(To be submitted in the letter head of the bidder)**

We, \_\_\_\_\_ (Name of the bidder) have submitted Bid No. \_\_\_\_\_ against Tender No. \_\_\_\_\_ dated \_\_\_\_\_ for “**Maintenance of OFC cable and other Telecom activities for a period of two years extendable by another one year upon review under PS5 Sector (ROW Chainage PLKM 352-497 & Spur Line PHQ - GHY Refinery Termianl)**”.

We hereby undertake that we meet the mandatory minimum Local Content (LC) requirement i.e. \_\_\_\_\_ % as per Clause No. 1.0 of BEC/BRC of the tender and as per provision of **Public Procurement (Preference to Make in India) Order, 2017 of Department for Promotion of Industry and Internal Trade (DPIIT), Govt. of India as revised vide Order No. P45021/2/2017-PP (BE-II) dated 16th September 2020 (and as amended time to time) with modifications as notified vide MoP&NG Order No. FP-20013/2/2017-FP-PNG-Part (4) (E-41432) dated 26th April 2022**, to bid against the subject tender.

**The percentage of local content in the bid is \_\_\_\_\_ %.**

For (Name of the firm \_\_\_\_\_)

Signature of Authorised Signatory/ POA

Name:

Designation:

Place:

Date:

(Affix Seal of the Organization here)

**(NOT APPLICABLE FOR THIS TENDER)**

**Proforma of Bank Guarantee towards Purchase Preference – Local Content**

Ref. No. \_\_\_\_\_ Bank Guarantee No. \_\_\_\_\_  
Dated \_\_\_\_\_

To  
Oil India Limited

\_\_\_\_\_  
\_\_\_\_\_  
India

Dear Sirs,

1. In consideration of \_\_\_\_\_ (hereinafter referred to as OIL, which expression shall, unless repugnant to the context or meaning thereof, include all its successors, administrators, executors and assignees) having entered into a CONTRACT No. \_\_\_\_\_ dated \_\_\_\_\_ (hereinafter called 'the CONTRACT' which expression shall include all the amendments thereto) with M/s \_\_\_\_\_ having its registered/head office at \_\_\_\_\_ (hereinafter referred to as the 'CONTRACTOR') which expression shall, unless repugnant to the context or meaning thereof include all its successors, administrators, executors and assignees) and OIL having agreed that the CONTRACTOR shall furnish to OIL a Bank guarantee for India Rupees/US\$ \_\_\_\_\_ for the faithful fulfillment of conditions pertaining to Local Content in accordance with the value mentioned in the certificate of Local Content submitted by the contractor for claiming purchase preference under the Purchase Preference Policy (linked with Local Content).
2. We (name of the bank) \_\_\_\_\_ registered under the laws of \_\_\_\_\_ having head/registered office at \_\_\_\_\_ (hereinafter referred to as "the Bank", which expression shall, unless repugnant to the context or meaning thereof, include all its successors, administrators, executors and permitted assignees) do hereby guarantee and undertake to pay to OIL immediately on first demand in writing any / all money to the extent of Indian Rs./US\$ (in figures) \_\_\_\_\_ (Indian Rupees/US Dollars (in \_\_\_\_\_ words) \_\_\_\_\_) without any demur, reservation, contest or protest and/or without any reference to the CONTRACTOR. Any such demand made by OIL on the Bank by serving a written notice shall be conclusive and binding, without any proof, on the bank as regards the amount due and payable, notwithstanding any dispute(s) pending before any Court, Tribunal, Arbitrator or any other authority and/or any other matter or thin whatsoever, as liability under these presents being absolute and unequivocal. We agree that the guarantee herein contained shall be irrevocable and shall continue to be enforceable until it is discharged by OIL in writing. This guarantee shall not be determined, discharged or affected by the liquidation, winding up, dissolution or insolvency of the CONTRACTOR and shall remain valid, binding and operating against the bank.
3. The Bank also agrees that OIL at its option shall be entitled to enforce this Guarantee against the Bank as a principal debtor, in the first instance, without proceeding

against the CONTRACTOR and notwithstanding any security or other guarantee that OIL may have in relation to the CONTRACTOR's liabilities.

4. The Bank further agrees the OIL shall have the fullest liberty without our consent and without affecting in any manner our obligations hereunder to vary any of the terms and conditions of the said CONTRACT or to extend time of performance by the said CONTRACTOR(s) from time to time or to postpone for any time or from time to time exercise of any of the powers vested in OIL against the said CONTRACTOR(s) and to forbear or enforce any of the terms and conditions relating to the said agreement and we shall not be relieved from our liability by reason of any such variation, or extension being granted to the said CONTRACTOR(s) or for any forbearance, act or omission on the part of OIL or any indulgence by OIL to the said CONTRACTOR(s) or any such matter or thing whatsoever which under the law relating to sureties would, but for this provision, have effect of so relieving us.
5. The Bank further agrees that the Guarantee herein contained shall remain in full force during the period that is taken for the performance of the CONTRACT and all dues of OIL under or by virtue of this CONTRACT have been fully paid and its claim satisfied or discharged or till OIL discharges this guarantee in writing, whichever is earlier.
6. This Guarantee shall not be discharged by any change in our constitution, in the constitution of OIL or that of the CONTRACTOR.
7. The Bank confirms that this guarantee has been issued with observance of appropriate laws of the country of issue.
8. The Bank also agrees that this guarantee shall be governed and construed in accordance with Indian Laws and subject to the exclusive jurisdiction of Indian Courts of the place from where the purchase CONTRACT has been placed.
9. Notwithstanding anything contained herein above, our liability under this Guarantee is limited to INR in figures) \_\_\_\_\_ (Indian Rupees/US Dollars (in words) \_\_\_\_\_) and our guarantee shall remain in force until \_\_\_\_\_(indicate the date of expiry of bank guarantee).

Any claim under this Guarantee must be received by us before the expiry of this Bank Guarantee. If no such claim has been received by us by the said date, the rights of OIL under this Guarantee will cease. However, if such a claim has been received by us within the said date, all the rights of OIL under this Guarantee shall be valid and shall not cease until we have satisfied that claim.

In witness whereof, the Bank through its authorized officer has set its hand and stamp on this \_\_\_\_\_ date of \_\_\_\_\_ 20\_\_\_\_ at \_\_\_\_\_

\_\_\_\_\_  
(Signature)

Full name, designation and address

**E-TENDER: CGI7847P25**

(in legible letters)

With Bank

Attorney as per power of

Attorney No. \_\_\_\_\_

Dated \_\_\_\_\_

**(NOT APPLICABLE FOR THIS TENDER)**

~~ON THE OFFICIAL PAD OF THE BIDDER TO BE EXECUTED BY THE AUTHORIZED SIGNATORY OF THE BIDDER~~

**Certificate of Compliance of FINANCIAL CRITERIA:**

~~Ref Clause No. Financial Criteria of the BRC/BEC of this Tender~~

~~I ..... the authorized signatory(s) of ..... (Company or firm name with address) do hereby solemnly affirm and declare / undertake as under:~~

~~The balance sheet/Financial Statements for the financial year **2023-2024** (as the case may be) has actually not been audited as on the Original Bid Closing Date.~~

~~Place: .....~~

~~Date: ..... Signature of the authorized signatory~~

~~Note: This certificate is to be issued only considering the time required for preparation of Financial Statements i.e. if the last date of preceding financial / accounting year falls within the preceding six months reckoned from the original bid closing date.~~

\*\*\*\*\*

**(Format of undertaking by Bidders towards submission of authentic information/documents  
(To be typed on the letter head of the bidder)**

Ref. No. \_\_\_\_\_

Date \_\_\_\_\_

**To,  
GM(C&P)  
OIL INDIA LIMITED  
GUWAHATI-781171**

**Sub: Undertaking of authenticity of information/documents submitted**  
**Ref: Your tender No. \_\_\_\_\_ Dated \_\_\_\_\_**

**Sir,**

With reference to our quotation against your above-referred tender, we hereby undertake that no fraudulent information/documents have been submitted by us.

We take full responsibility for the submission of authentic information/documents against the above cited bid.

We also agree that, during any stage of the tender/contract agreement, in case any of the information/documents submitted by us are found to be false/forged/fraudulent, OIL has right to reject our bid at any stage including forfeiture of our EMD and/or PBG and/or cancel the award of contract and/or carry out any other penal action on us, as deemed fit.

Yours faithfully,  
For (type name of the firm here)

Signature of Authorised Signatory

Name:

Designation:

Phone No.

Place:

Date:

(Affix Seal of the Organization here, if applicable)

\*\*\*\*\*

**PROFORMA- N**

[TO BE FILLED-UP / SUBMITTED BY THE VENDOR ON ITS LETTER HEAD FOR E-REMITTANCE]

Name:

FULL Address:

Phone Number :

Mobile Number :

E-mail address :

FAX Number :

Bank Account Number:  
(in which the Bidder wants remittance against invoices)

Bank Name :

Branch :

Address of the Bank:

Bank Code :

IFSC/RTGS Code of the Bank:

NEFT Code of the Bank :

PAN Number :

GST Registration Number:

\_\_\_\_\_  
Signature of Vendor with Official Seal

Note: This declaration shall be printed on letter head of the Bidder and shall be signed by a competent person.



**PROFORMA-O**

**FORMAT FOR UNDERTAKING (IN TERMS OF TENDER NO. CGI7847P25)**

**(On Non-Judicial Stamp Paper of Rs. 100/-) TO BE NOTARISED**

To  
GM(C&P)  
OIL INDIA LIMITED  
GUWAHATI

Dear Sirs,

**UNDERTAKING/DECLARATION BY THE BIDDER IN RESPECT OF TENDER NO  
CGI7847P25**

This is in connection with the Bid submitted by me/us, ..... (Name of Bidder), against Tender No. **CGI7847P25** for “ **Maintenance of OFC cable and other Telecom activities for a period of two years extendable by another one year upon review under PS5 Sector(ROW Chainage PLKM 352-497 & Spur Line PHQ - GHY Refinery Termianl)**”.

I/We, the afore mentioned Bidder against the subject tender, hereby declare that my/our quoted rates include the following -

- (a) Labour wages as per Minimum Wages Act and notifications issued by the Central Govt. from time to time, including P.F, insurance and Bonus.
- (b) Material and Equipment (if any) cost.
- (c) PPE cost.
- (d) IME (Initial Medical Examination) cost.
- (e) Other charges / cost including overheads, profit, insurance and handling charge..

I/We, the afore mentioned Bidder against the subject tender take note that minimum wages may increase from time to time as notified by statutory authority and Central Govt. and undertake that I/We shall not make Company (i.e. OIL) liable to reimburse me/us for such statutory increase in wage rates of the labours/workers engaged by me/us during the entire period of the contract, including extension if any. Currently, such increase in the wage rates is twice in a year. I/We have bid after considering this increase in wage rates for the entire period of Contract including extension provision.

I/We, the afore mentioned Bidder against the subject tender, further undertake that I/We will pay my/our workers the existing Daily wages as notified under the Minimum Wages Act from time to time by the Central Govt. and such statutory or any other increase in the wages rates including consequent increase in statutory contributions like provident fund etc. of contract labours engaged by me/us shall be borne solely by me/us during the entire period of the contract, including extension if any, without any cost implication whatsoever upon the Company.

I/We further agree and undertake that in case of any violation of the above undertaking, Oil India Limited (OIL) shall be at liberty to take appropriate action against me/us in terms of the Tender/Contract including but not limited to termination of contract and debarment from future

business with OIL. I shall duly comply with all the statutory obligations, more particularly under applicable labour laws. I further agree and undertake that in case of any dispute or claims arise out of my non-compliance of statutory obligations under the Contract, by the Labourers engaged by me or by any statutory authorities, I shall only be responsible for the same and hold the Company harmless against such dispute or claims. I further authorize the Company, in the event of my default or non-compliance of any statutory obligations, to deduct/recover and adjust such amount or claim against my Bills due under the Contract or against any other existing or future Contracts with the Company including performance security.

I/We declare that the information given above is true and any misstatement, misrepresentation, or suppression of facts in connection with the above undertaking may entail rejection of the bid and cancellation of contract, if awarded.

Yours faithfully,

1. Authorized Signatory with Seal

\_\_\_\_\_  
(Bidder)

Place:-

Date:-

\*\*\*\*\*  
\_\_\_\_\_

**PROFORMA-P**

To,

**Chief General Manager (F&A)-PL**

Oil India Limited

Pipeline HQ, Narangi , Guwahati ,Assam-781171

Dear Sir,

Sub: E-Payments vide RTGS/NEFT

I/We request and hereby authorise you to execute E-Payment vide RTGS/NEFT modes to My /Our Bank account as per the details given below:

(A) BANK DETAILS

- 1. Bank A/c No. ( Must Enclose Cancelled Cheque)
- 2. Account Type Saving Bank/ Curent Account
- 3. Bank Branch
- 4. Bank Address
- 5. IFSC Code
- 6. MICR No.

(B) VENDOR DETAILS :

- 1. Vendor Code ( See the vendor code given in the PO/Contract)
- 2. Name
- 3. PAN No. (Must enclosed self-attested photo copy of PAN Card )
- 4. Address with Mobile/Telephone No.
- 5. ~~VAT TIN No.~~
- 6. ~~CST Regn. No.~~
- 7. GSTIN. No.
- 8. ~~Central Excise Regn.No.~~
- 9. Email ID

I/We hereby declare that the particulars given above are correct and complete. I/We confirm that I/we shall bear the charges, if any levied by my/our bank for the credit in our above account through NEFT. If the transaction is delayed or lost because of incomplete or incorrect information, we would not hold the company responsible.

Thanking you,

Date:

Signatory & Stamp

\_\_\_\_\_  
Authorised

.....  
Bank Certificate

We confirm that the details given above are correct as per our records.

Date:

\_\_\_\_\_  
Place:

Authorised Bank Official

Signature, Code & Stamp of

\*\*\*\*\*

**PROFORMA-Q**

**PROFORMA OF INDEMNITY BOND FOR SUPPLY OF MATERIALS BY PURCHASER/ OWNER**

***(To be executed on non-judicial stamp paper of appropriate value)***

WHEREAS OIL INDIA Ltd. (hereinafter referred to as "OIL") which expression shall unless repugnant to the context includes their legal representatives, successors and assigns having their Pipeline Headquarters at PO Udayan Vihar, Guwahati-781171, Assam has entered into an Contract with \_\_\_\_ (hereinafter referred to as the CONTRACTOR which expression shall unless repugnant to the context include their legal representatives, successors and assigns) for \_\_ on the terms and conditions as set out, inter-alia, in the Contract No..... Dated..... and various documents forming part thereof hereinafter collectively referred to as the "CONTRACT" which expression shall include all amendments, modifications and/or variations thereto.

AND WHEREAS

- i) OIL has agreed to supply to the CONTRACTOR, equipment, plants and materials (finished, semi-finished and raw) for the purpose of EXECUTION of the said CONTRACT by the CONTRACTOR (the equipment, plants and materials to be supplied by OIL to the CONTRACTOR, hereinafter for the sake of brevity referred to as the "said materials") and pending execution by the CONTRACTOR of the CONTRACT incorporating the said materials, the said materials shall be under the custody and charge of the CONTRACTOR and shall be kept, stored, altered, worked upon and/or fabricated at the sole risk and expense of the CONTRACTOR.
- ii) As a pre-condition to the supply of the said materials by OIL to the CONTRACTOR, OIL has required the CONTRACTOR to furnish to OIL an Indemnity Bond in the manner and upon terms and conditions hereinafter indicated.

NOW, THEREFORE, in consideration of the premises aforesaid the CONTRACTOR hereby irrevocably and unconditionally undertakes to indemnify and keep indemnified OIL from and against all loss, damage and destruction (inclusive but not limited to any or all loss or damage or destruction to or of the said materials or any item or part thereof by theft, pilferage, fire, flood, storm, tempest, lightning, explosion, storage, chemical or physical action or reaction, binding, warping, exposure, rusting, faulty workmanship, faulty fabrication, or faulty method or technique of fabrication, strike, riot, civil commotion, or other act or omission or commission whatsoever within or beyond the control of the CONTRACTOR, misuse and misappropriation (inclusive but not limited to the misuse or misappropriation by the CONTRACTOR and the CONTRACTOR's servants and/or agents) whatsoever to, or of in the said materials or any part of them thereof from the date that the same or relative part of item thereof was supplied to the CONTRACTOR up to and until the date of return to OIL of the said materials or relative part of item thereof or completed fabricated works(s) incorporating the said material and undertake to pay to OIL forthwith on demand in writing

without protest or demur the value as specified by OIL of the said material or item or part thereof, lost, damaged, destroyed, misused and/or misappropriated, as the case may be or, together with OIL's costs and expenses (inclusive of but not limited to handling, transportation, cartage, insurance, freight, packing and inspection costs/or expenses up to) and aggregate limit of

\_\_\_\_\_ (In words \_\_\_\_\_)

\_\_\_\_\_ Only).

AND THE CONTRACTOR hereby agrees with OIL that:

- i) This Indemnity/Undertaking shall be a continuing Indemnity/Undertaking and shall remain valid and irrevocable for all claims of OIL arising hereunder up to and until the midnight of \_\_\_\_\_ . However, if the CONTRACT for which this Indemnity/Undertaking is given is not completed by this date, the CONTRACTOR hereby agrees to extend the Indemnity/Undertaking till such time as is required to fulfill the CONTRACT.
- ii) This Indemnity/Undertaking shall not be determined by any change in constitution or upon insolvency of the CONTRACTOR but shall be in all respects and for all purposes be binding and operative until payment of all moneys payable to OIL in terms of hereof.
- iii) The mere statement of allegation made by or on behalf of OIL in any notice or demand or other writing addressed to the CONTRACTOR as to any of the said material or item or part thereof having been lost, damaged, destroyed, misused or misappropriated while in the custody of the CONTRACTOR and/or prior to completion of the completed fabricated work(s) and delivery to job site thereof incorporating the said materials shall be conclusive of the factum of the said material or item or part thereof having been supplied to the CONTRACTOR and/or the loss, damage, destruction, misuse or misappropriation thereof, as the case may be, while in the custody of the CONTRACTOR and/or prior to the completion of the completed fabricated work(s) and delivery to job site thereof incorporating the said materials without necessity on the part of OIL to produce any documentary proof or other evidence whatsoever in support of this.
- iv) The amount stated in any notice of demand addressed by OIL to the CONTRACTOR as to the value of such said materials lost, damaged, destroyed, misused or misappropriated, inclusive relative to the costs and expenses incurred by OIL in connection therewith shall be conclusive of the value of such said materials and the said cost and expenses as also of the amount liable to be paid to OIL to produce any voucher, bill or other documentation or evidence whatsoever in support thereof and such amount shall be paid without any demur and on demand and no dispute shall be raised concerning the same.

**E-TENDER: CGI7847P25**

The undersigned has full power to execute this Indemnity Bond on behalf of the

CONTRACTOR under the Power of Attorney dated \_\_\_\_\_.

Place:

(SIGNED BY COMPETENT AUTHORITY)  
Official seal of the CONTRACTOR

Dated:

**DECLARATION FOR BID SECURITY**

To,

M/s. Oil India Limited

.....,

.....

Sub: .....

Tender No:.....

Dear Madam/Sir,

After examining / reviewing provisions of above referred tender documents (including all corrigendum/ Addenda), we M/s. .... (Name of Bidder) have submitted our offer / bid no.....

We, M/s. ....(Name of Bidder) hereby understand that, according to your conditions, we are submitting this Declaration for Bid Security.

We understand that we will be put on watch list/holiday/banning list (as per policies of OIL INDIA in this regard), if we are in breach of our obligation(s) as per following:

- (d) have withdrawn/modified/amended, impairs or derogates from the tender, my/our Bid during the period of bid validity specified in the form of Bid; or
- (e) having been notified of the acceptance of our Bid by the OIL INDIA LIMITED during the period of bid validity:
  - (iv) fail or refuse to execute the Contract, if required, or
  - (v) fail or refuse to furnish the Contract Performance Security, in accordance provisions of tender document.
  - (vi) Fail or refuse to accept 'arithmetical corrections' as per provision of tender document.
- (f) having indulged in corrupt/fraudulent/collusive/coercive practice as per procedure.

Place:

[Signature of Authorized Signatory of Bidder]

Date:

Name:

Designation:

Seal:

\*\*\*\*\*  
\_\_\_\_\_

**ANNEXURE-AA**

**CERTIFICATE OF ANNUAL TURNOVER & NETWORTH**

(To be issued by practicing Chartered/Cost Accountant Firm on their Letter Head)

**TO WHOM IT MAY CONCERN**

This is to certify that the following financial positions extracted from the audited financial statement of M/s\_\_\_\_\_ (Name of the bidder) for the last three(3) completed accounting years up to\_\_\_\_\_ (as the case may be) are correct.

<b>YEAR</b>	<b>TURNOVER(Rs.)</b>	<b>NETWORTH(Rs.)</b>
<b>2021-2022</b>		
<b>2022-2023</b>		
<b>2023-2024</b>		

Place:

Date:

Seal:

Membership Code and Registration No.

**UDIN :**

Signature

**APPENDIX-A**

**GENERAL HSE POINTS**

1.0 It will be solely the Contractor's responsibility to fulfil all the legal formalities with respect in the Health, Safety & Environmental aspects of the entire job (namely, the persons employed by him, the equipment, the environment etc.) under the jurisdiction of the district of that state where it is operating. Ensure that all sub-Contractors hired by him comply with the same requirement as the Contractor himself and shall be liable for ensuring compliance all HSE laws by the sub or sub-Contractors.

2.0 Every person deployed by the Contractor in a mine must wear safety gadgets to be provided by the Contractor. The Contractor shall provide proper Personnel Protective Equipment as per the hazard identified and risk assessed for the job and conforming to statutory requirement and the Company PPE schedule. Safety appliances like protect footwear, safety helmet and full body harness has to be DGMS approved. Necessary supportive document shall have to be submitted as proof. If the Contractor fails to provide the safety items as mentioned above to the working personnel, the Contractor may apply to the Company (OIL) for providing the same. OIL will provide the safety items, if available, but in turn. OIL will recover the actual cost of the items by deducting from Contractor's bill. However, it will be the Contractor's sole responsibility to ensure that the persons engaged by him in the mines use the proper PPE while at work. All the safety gears mentioned above are to be provided to the working personnel before commencement of the work.

3.0 The Contractor shall prepare written Safe Operating Procedure (SOP) for the work to be carried out, including as assessment of risk, wherever possible and safe methods to deal with it/them. The SOP should clearly state the risk arising to men, machineries and materials from the mining operation/operations to be done by the Contractor and how it is to be managed.

4.0 The Contractor shall provide a copy of SOP to the person designated the Mine Owner who shall be supervising the Contractor's work.

5.0 Keep an up to date SOP and provide a copy to changes to a person designed by the Mine Owner/Agent/Manager

6.0 The Contractor has to ensure that all work is carried out in accordance with the Statute and SOP and for the purpose he may deploy adequate qualified and competent personnel for the purpose of carrying out the job in a safe manner. For work of a specified scope/nature, he should develop and provide to the Mine Owner a site

7.0 All persons deployed by the Contractor for working in mine must undergo Mines Vocational Training, initial medical examination, PME. They should be issued cards stating the name of the Contractor and the work and its validity period, indicating status of MVT, IME & PME.

8.0 The Contractor shall submit to DGMS—indicating – name of his firm Registration Number, name , Address of person heading the firm, nature of work, type of deployment of work persons, No. of work persons deployed, how many work

persons hold VT Certificate, how many work persons undergone IME and type of medical coverage given to the work persons.

9.0 The return shall be submitted quarterly (by 10<sup>th</sup> of April, July, October & January) for contracts of more than one year. However, for contracts of less than one year, returns shall be submitted monthly.

10.0 It will be entirely the responsibility of the Contractor/ his Supervisor/Representative to ensure strict adherence to all HSE measures and statutory rules during operation in Oil's installations and safety of workers engaged by him. The crew members will not refuse to follow any instruction given by the Company's Installation Manager/Safety Officer/Engineer/Official/Supervisor/Junior Engineer for safe operation.

11.0 Any compensation arising out of the job carried out by the Contractor whether related to pollution, Safety or Health will be paid by the Contractor only.

12.0 Any compensation arising due to accident of the Contractor's personnel while carrying out the job, will be payable by the Contractor.

13.0 The Contractor shall have to report all incidents including near miss to installation manager/Departmental Representative of concerned department of OIL.

14.0 The Contractor has to keep a register of the persons employed by him/her. The Contractor's supervisor shall take and main attendance of his men every day for the work, punctuality.

15.0 If the Company arranges any safety class/training for the working personnel at site (Company employees, Contractor worker etc.) the Contractor will not have any objection to any such training.

16.0 The health check-up of Contractor's personnel is to be done by the Contractor in authorized Health Centres as per Oil's requirement & proof of such test(s) is to be submitted to OIL. The frequency of periodic medical examinations should be every five years for the employees below 45 years of age and every three years for employees of 45 years of age and above.

17.0 To arrange daily tool box meeting and regular site safety meeting and maintain records.

18.0 Records of daily attendance, accident report etc. are to be maintained in Form B, E, J (as per Mines Rules 1955) by the Contractor.

19.0 A Contractor employee must, while at work, take reasonable care for the health and safety of people who are all the employee's place of work and who may be affected by the employee's act or omissions at work.

20.0 A Contractor employee must, while at work, co-operate with his or her employer or other persons so far as is necessary to enable compliance with any requirement under the act or the regulations that is imposed in the interest of health, safety and welfare of the employee or any other person.

21.0 Contractor's arrangements for health for health and safety management shall be consistent with those for the mine owner.

22.0 In case Contractor is found non-compliant of HSE laws as required the Company will have the right for directing the Contractor to take action comply with the requirements, and for further non-compliance, the Contractor will be penalized prevailing relevant Acts/Rules/Regulations.

23.0 When there is a significant risk to health, environment or safety of a persons or pace arising because of a non-compliance of HSE measure the Company will have the right to direct the Contractor to cease work until the non-compliance is corrected.

24.0 The Contractor should prevent the frequent change of his contractual employees as far as practicable.

25.0 The Contractor should frame a mutually agreed bridging document between OIL and the Contractor with roles and responsibilities clearly defined.

26.0 For any HSE matters not specified in the Contract document, the Contractor will abide the relevant and prevailing Acts/Rules/Regulations pertaining to Health, Safety and Environment.

\*\*\*\*\*

**Procedure for obtaining Labour License under Contract Labour (R&A) Act, 1970 & Central Rules-1971**

Every Contractor to whom this Act applies shall execute any work through Contract Labour only after obtaining valid license from Licensing Officer. To obtain license contractor is required to submit:

- i) Application in Form IV in triplicate duly filled (Name of the Proprietor/Partner or the Directors/Responsible person in case of firm/company, complete postal address including Pin Code number, Telephone Number, Fax Number & E-mail address, if any), correct details of PE and work to be executed etc. correctly against all columns;
- ii) In case contractor is registered under the Companies Act and applicant is other than Director then he should be holding valid Power of Attorney.
- iii) Original Form-V issued by PE
- iv) Demand Draft for license fees and security deposit payable in favour of Regional Labour Commissioner Guwahati along with duly filled central challan (in TR-6) duly signed by applicant in quadruplicate for each demand draft;
- v) Copy of Work Order;
- vi) Copy of Partnership Deed and in case of Company, the application should be accompanied with Memorandum of Association/Article of Association;

- Note: 1. Application form complete in all respect shall be either personally delivered to the Licensing Officer or can be sent by Registered A.D. Post.
2. Contractors, may intimate Dy. Chief Labour Commissioner, Guwahati, for expediting/suitable action if they do not receive license nor any communication within a week.
3. Contractors are not required to visit office of Licensing Officer unnecessarily for obtaining license until and unless they have been specifically advised to appear in person. Appearance of contractors in the office of licensing officer for obtaining license by persuasion will be viewed seriously.

\*\*\*\*\*

**APPENDIX-C**

**DECLARATION ABOUT BIDDER'S FINANCIAL STANDING**

To,

GM(C&P)  
Contracts Department, OLINDIA LIMITED, PHQ, GUWAHATI  
PIN-781171  
Dist. KAMRUP (M),  
Assam India

**Sub:** Undertaking/Declaration regarding financial standing

**Ref:** Tender No. \_\_\_\_\_

We, \_\_\_\_\_ (name of bidder), hereby confirm that:

- (1) We are neither bankrupt nor undergoing any insolvency resolution process or liquidation or bankruptcy proceeding under any law.

**(OR)**

- (2) No insolvency resolution process or liquidation or bankruptcy proceeding is initiated under any law against us.

Place: \_\_\_\_\_

Date: \_\_\_\_\_

\_\_\_\_\_  
(Name & Signature of the  
authorised  
signatory of the bidder)

**APPENDIX-D**

**DECLARATION THAT BIDDER IS NOT UNDER HOLIDAY LIST/DELISTED/BLACKLISTED/DEBARRED IN OIL**

To,

GM(C&P)  
Contracts Department, ~~OLNDALMIED~~ PHQ, GUWAHATI  
PIN-781171  
Dist. KAMRUP (M),  
Assam India

**Sub:** Undertaking/Declaration regarding Holiday List, debarment etc.

**Ref:** Tender No. \_\_\_\_\_

We, \_\_\_\_\_ (Name of the bidder) hereby declare that neither our company nor any of its allied concerns, partners or associates or directors or proprietors involved in any capacity, are currently put on holiday list/banning list by OIL debaring us/them from carrying on business dealings with OIL.

Place: \_\_\_\_\_

Date: \_\_\_\_\_

\_\_\_\_\_  
(Name & Signature of the  
authorised  
signatory of the bidder)

**Annexure-I**

**RESTRICTIONS ON PROCUREMENT FROM A BIDDER OF A COUNTRY WHICH SHARES LAND BORDER WITH INDIA:**

Subject to **Order No. F.7/10/2021-PPD (1) dated 23.02.2023** issued by Department of Expenditure, Ministry of Finance, Govt. of India, Bidders should take note of the following:

- 1.0 Any bidder from a country which shares a land border with India will be eligible to bid in this tender only if the bidder is registered with the Competent Authority [Registration Committee constituted by the Department for Promotion of Industry and Internal Trade (DPIIT)]. Further, any bidder (including bidder from India) having specified Transfer of Technology (ToT) arrangement with an entity from a country which shares a land border with India, shall also require to be registered with the same competent authority to be eligible to bid in this tender.
- 2.0 "Bidder" (including the term 'tenderer', 'consultant' or 'service provider' in certain contexts) means any person or firm or company, including any member of a consortium or joint venture (that is an association of several persons, or firms or companies), every artificial juridical person not falling in any of the descriptions of bidders stated hereinbefore, including any agency branch or office controlled by such person, participating in a procurement process.
- 3.0 "Bidder (or entity) from a country which shares a land border with India" for the purpose of this Order means:
  - a. An entity incorporated, established or registered in such a country; or
  - b. A subsidiary of an entity incorporated, established or registered in such a country; or
  - c. An entity substantially controlled through entities incorporated, established or registered in such a country; or
  - d. An entity whose beneficial owner is situated in such a country; or
  - e. An Indian (or other) agent of such an entity; or
  - f. A natural person who is a citizen of such a country; or
  - g. A consortium or joint venture where any member of the consortium or joint venture falls under any of the above
- 4.0 The beneficial owner for the purpose of para 3.0 above will be as under:
  - 4.1 In case of a company or Limited Liability Partnership, the beneficial owner is the natural person(s), who, whether acting alone or together, or through one or more juridical person, has a controlling ownership interest or who exercises control through other means.

Explanation:

- a. "Controlling ownership interest" means ownership of or entitlement to more than twenty-five percent of shares or capital or profits of the company.
  - b. "Control" shall include the right to appoint majority of the directors or to control the management or policy decisions including by virtue of their shareholding or management rights or shareholder's agreements or voting agreements.
- 4.2 In case of a partnership firm, the beneficial owner is the natural person(s) who, whether acting alone or together, or through one or more juridical person, has ownership of entitlement to more than fifteen percent of capital or profits of the partnership;
- 4.3 In case of an unincorporated association or body of individuals, the beneficial owner is the natural person(s), who, whether acting alone or together, or through one or more juridical person, has ownership of or entitlement to more than fifteen percent of the property or capital or profits of such association or body of individuals;
- 4.4 Where no natural person is identified under (4.1) or (4.2) or (4.3) above, the beneficial owner is the relevant natural person who holds the position of senior managing official;
- 4.5 In case of a trust, the identification of beneficial owner(s) shall include identification of the author of the trust, the trustee, the beneficiaries with fifteen percent or more interest in the trust and any other natural person exercising ultimate effective control over the trust through a chain of control or ownership.
- 5.0 An Agent is a person employed to do any act for another, or to represent another in dealings with third person.
- 6.0 The successful bidder shall not be allowed to sub-contract works to any contractor from a country which shares a land border with India unless such contractor is registered with the Competent Authority.
- 7.0 **Validity of Registration:** The registration should be valid at the time of submission of bid and at the time of acceptance of bid. If the bidder was validly registered at the time of acceptance/placement of order, registration shall not be a relevant consideration during contract execution.
- 8.0 **Undertaking regarding compliance:** The bidders are required to provide undertakings as per **Exhibits – I, II & III** along with their bid towards compliance of the above guidelines for participation in this tender. If the undertakings given by a bidder whose bid is accepted is found to be false, this would be a ground for debarment/action as per OIL's Banning Policy and further legal action in accordance with law.

**UNDERTAKING TOWARDS COMPLIANCE OF PROVISIONS FOR  
RESTRICTIONS ON PROCUREMENT FROM A BIDDER OF A COUNTRY WHICH  
SHARES LAND BORDER WITH INDIA**

We, M/s \_\_\_\_\_ , have read the clause regarding restrictions on procurement from a bidder of a country which shares a land border with India; we certify that we are not from such a country/or if from such a country, have been registered with the Competent Authority. We hereby certify that we fulfil all requirements in this regard and is eligible to be considered. *[wherever applicable, evidence of valid registration by the Competent Authority shall be attached]*

Yours faithfully,  
For (type name of the firm here)

Signature of Authorised Signatory

Name:

Designation:

Phone No.

Place:

Date:

(Affix Seal of the Organization here, if applicable)

**UNDERTAKING FOR WORKS INVOLVING POSSIBILITY OF SUB-  
CONTRACTING**

We, M/s \_\_\_\_\_ , have read the clause regarding restrictions on procurement from a bidder of a country which shares a land border with India and on sub-contracting to contractors from such-countries, we certify that we are not from such a country/or if from such a country, have been registered with the Competent Authority and will not sub-contract any work to a contractor from such countries unless such contractor is registered with the Competent Authority. We hereby certify that we fulfil all requirements in this regard and is eligible to be considered. *[wherever applicable, evidence of valid registration by the Competent Authority shall be attached]*

Yours faithfully,  
For (type name of the firm here)

Signature of Authorized Signatory

Name:

Designation:

Phone No.

Place:

Date:

(Affix Seal of the Organization here, if applicable)

**ADDITIONAL UNDERTAKING BY BIDDER IN CASES OF SPECIFIED  
TRANSFER OF TECHNOLOGY(ToT)**

We, M/s \_\_\_\_\_ , have read the clause regarding restrictions on procurement from a bidder having Transfer of Technology (ToT) arrangement. We certify that we do not have any ToT arrangement requiring registration with the competent authority.

OR

We, M/s \_\_\_\_\_ , have read the clause regarding restrictions on procurement from a bidder having Transfer of Technology (ToT) arrangement. We certify that we have valid registration to participate in this procurement. *[Evidence of valid registration by the Competent Authority shall be attached]*

Yours faithfully,

For (type name of the firm here)

Signature of Authorised Signatory

Name:

Designation:

Phone No.

Place:

Date:

(Affix Seal of the Organization here, if applicable.)

**CHECKLIST**

**DATE:**

**TENDER NO:** CGI7847P25

**BIDDER:**

**☑ = SUBMITTED, ☒= NOT SUBMITTED**

<b>DOCUMENTS TO BE SUBMITTED ALONG WITH THE BID</b>	<b>SUBMITTED/NOT SUBMITTED</b>	<b>REMARKS</b>
Price Schedule Format, (Proforma-A) SEC-II		
Bid Form, (Proforma-B)		
Statement of Non-Compliance, (Proforma-C)		
Bid Security <del>declaration</del> Form (Proforma-D) <b>if applicable</b>		
Performance Security Form, (Proforma-E)		
Sample Agreement Form (Proforma-F)		
Proforma of Letter of Authority (Proforma-G)		
Authorisation for Attending Bid Opening (Proforma-H)		
Integrity Pact (Proforma -I) <b>if applicable</b>		
Safety Measures (Proforma – J)		
UNDERTAKING TOWARDS PURCHASE PREFERENCE(Proforma -K) <b>if applicable</b>		
UNDERTAKING FOR LOCAL CONTENT (Proforma -K) <b>if applicable</b>		
Proforma of Bank Guarantee towards PP-LC (Proforma -K1) <b>if applicable</b>		
Certificate of Compliance of Financial Criteria (Proforma -L) <b>if applicable</b>		
Format of undertaking by Bidders towards submission of authentic information/documents (Proforma -M)		
E-remittance format (Proforma -N)		
Labour wages& security Declaration (Proforma -O)		
E-Payments vide RTGS/NEFT (Proforma -P)		
Format of indemnity bond for supply of materials by purchaser/ owner (Proforma -Q)		
<b>DECLARATION FOR BID SECURITY (Proforma -R) if applicable</b>		
<b>ANNEXURE-AA: CERTIFICATE OF ANNUAL TURNOVER &amp; NETWORTH</b>		
<b>Documents for proof of requisite experience and relevant technical requirements</b>		
<b>MSME UDYAM REGISTRATION CERTIFICATE(if applicable)</b>		
GENERAL HSE POINTS(APPENDIX-A)		
Restriction on procurement from a bidder of a country which shares land border with India( <b>Annexure -I, EXHIBIT-I, II, III</b> )		
DECLARATION ABOUT BIDDER'S FINANCIAL STANDING(APPENDIX-C)		
DECLARATION THAT BIDDER IS NOT UNDER HOLIDAY LIST/DELISTED/BLACKLISTED/DEBARRED IN OIL(APPENDIX-D)		