

**FORWARDING LETTER**

**TENDER INFORMATION SUMMARY**

1	Bid Security and validity	:	<b>INR 2,94,000.00</b> (Note: Bid Security if submitted in the form of BG/e-PBG must be valid till <b>07.09.2025</b> )
2	Performance Guarantee	:	Applicable @ 5% of Order value if PO value is more than Rs. 10 Lakhs
3	Integrity Pact	:	<b>Applicable</b>
4	MSE Purchase Preference	:	<b>Applicable</b>
5	PPP-MII Purchase Preference	:	<b>Applicable</b>
6	Preference to domestically manufactured Iron and Steel product (DMI&SP Policy)	:	Not Applicable
7	Restrictions on procurement from a bidder of a country which shares a land border with India	:	<b>Applicable</b>
8	Banning Policy	:	<b>Applicable</b>
9	Pre despatch inspection	:	Not Applicable
10	Third party inspection	:	<b>Not Applicable</b>
11	Installation & Commissioning	:	Not Applicable
12	Training	:	Not Applicable
13	AMC	:	Not Applicable
14	Pre-bid conference	:	Not Applicable
15	OIL's PR No.	:	<b>1425670</b> . Kindly quote this reference number for all correspondence with OIL.

**LIST OF ANNEXURES**

	ANNEXURE-I	:	Scope of Work/Technical Specifications etc.
	ANNEXURE-II	:	Bid Evaluation Criteria/ Bid Rejection Criteria
	ANNEXURE-III	:	General Notes to Bidders
	ANNEXURE-IV	:	Evaluation matrix for Technical Specification (To be submitted along with the bid)
	ANNEXURE-V	:	Evaluation matrix for Bid Evaluation Criteria (To be submitted along with the bid)

## **ANNEXURE - I**

### **Scope of Work/ Technical Specifications**

#### **750 SHORT TON WELDLESS ELEVATOR LINKS**

Elevator Links, serve as a connection between the Top-Drive and the Elevator, or as an extension/connection of two Elevator Links and are designed for vertical holding and lifting operations.

750 Short Ton Rated Weldless Elevator Links, designed, manufactured, tested, certified and monogrammed as per API specification 8C (latest edition), PSL-1, SR-1 and SR-3, as per the following specification:

Quantity: 04 (four) numbers [02 (two) pairs]

#### **A) SPECIFICATIONS:**

- i) Minimum Load Capacity : 750 Short Ton (150,00,00 lbs.)
- ii) Size : 4.3/4 inch (120.65 mm)
- iii) Length : 168 inch (4267.20 mm)
- iv) Product Specification Level : PSL-1
- v) Supplementary Requirement : SR-1 and SR-3

#### **B) DESIGN FEATURES:**

- i) Designed, Manufactured, Tested, Certified and Monogrammed as per API Spec. 8C (latest edition), PSL-1, SR-1 and SR-3
- ii) Suitable to hang elevators from top drive systems, hooks, beackets and link adaptors in on-shore drilling rigs
- iii) Forged construction from a single piece of high grade alloy steel
- iv) Operating environment: Standard
- v) Proof load tested as per API 8C, SR-1

#### **C) DOCUMENTATION:**

The following documentation should be provided in English language along with the item.

- i) User Manual: 01(one) No.
- ii) Documentation consisting of Manufacturing Record Book as per SR-3 (API-8C latest edition), inclusive of Mill test certificate, Ultrasonic test reports, Proof load test report/certificate and subsequent examination reports (as applicable under SR-1 of API-8C latest edition) in Electronic/Hard copy format-01(one) Set.

Elevator Link PN	Size	Rated capacity (ton)
43168-Y	4.3/4" X 168"	750 Short Ton

Main dimensions of Elevator Links

Size	x	a	b	c	d	e	f	g	h
4.3/4"	4.3/4"	10"	15.1/2"	4.59/64"	10"	15.1/2"	4.3/4"	19.1/2"	19.1/2"

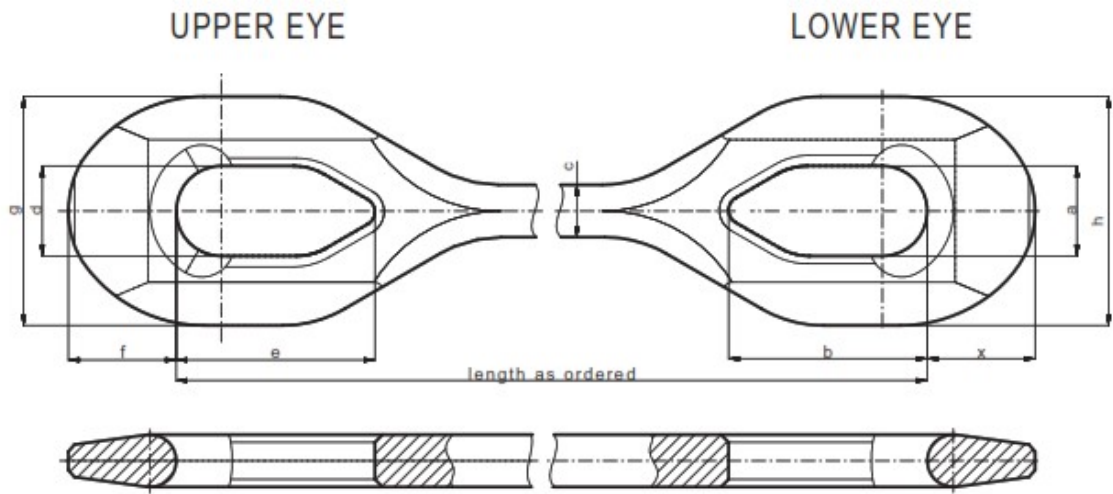

**GENERAL NOTES TO BIDDERS:**

1. The item must be brand new, unused & of prime quality. Bidder shall warrant (in the event of an order) that the product supplied will be free from all defects & fault in material, workmanship & manufacture and shall be in full conformity with ordered specifications. This clause shall be valid for 18 months from date of despatch/shipment or 12 months from the date of receipt at Duliajan, Assam, India whichever is earlier. The defective materials, if any, rejected by us shall be replaced by the supplier at their own expense. Bidders must confirm the same while quoting.
2. The Bidder should indicate the name of the manufacturer of the offered item in their quotation.
3. The bidder must specify the offered item in details, forwarding relevant product catalogue, literature, detailed drawings with exploded views of each and every item of the offered product with complete spare parts list & clearly indicating the various parts with part numbers along with their quotation.
4. The item is to be designed, manufactured, tested, certified and monogrammed as per API spec 8C (latest edition), PSL-1 & SR-1. Bidders are required to forward currently valid API Spec. 8C, PSL-1 certificate of the manufacturer along with the quotation.
5. The item shall be given a Proof Load Test as per API spec 8C (latest edition), SR-1 and certificate of Proof Load Test to be supplied along with the supply of item. Bidder should categorically confirm while quoting.
6. Necessary marking on the item shall be done as per API Spec. 8C (latest edition), PSL-1, SR-1 & SR3. Additionally, purchase order number and manufacturer's name have to be stamped on the body of the item. Bidder should categorically confirm while quoting.
7. In the event of order, the supply must include the manufacturing data/record book pertaining to the item as per API Spec. 8C (latest edition), SR-3 in hard copy format. Bidder should categorically confirm while quoting.
8. Bidder should note that in the event of an order, the API 8C, PSL-1 license for manufacturing the Link Block along with authorization for API monogramming should be valid, without any break, till execution of purchase order. Valid API 8C, PSL-1 certificate should be submitted along with the supply. Bidder should categorically confirm compliance while quoting.
9. Any deviation(s) from the tender specification should be clearly highlighted specifying justification in support of deviation.
10. Bidder to sign and submit the completely filled up Technical check list and Technical Evaluation Matrix for Bid evaluation criteria and Technical specification along with the quotation.

## ANNEXURE – II

### BID REJECTION CRITERIA (BEC/BRC)

#### **BID EVALUATION CRITERIA/BID REJECTION CRITERIA**

The bids shall broadly conform to the specifications and terms and conditions given in this bid document. Bids shall be rejected in case the items offered do not conform to required parameters stipulated in the technical specifications and to the respective international/national standards wherever stipulated. Notwithstanding the general conformity of the bids to the stipulated specifications and terms and conditions, the following requirements will have to be particularly met by the Bidders without which the same will be considered as non-responsive and rejected.

#### **A. BID REJECTION CRITERIA**

##### **A.1 TECHNICAL**

1. The Items shall be manufactured & tested as per relevant API norms as specified in the Tender (IF APPLICABLE). Bidder must confirm.

##### **2. EXPERIENCE**

##### **2.A. MANUFACTURERS EXPERIENCE: IN CASE THE BIDDER IS THE MANUFACTURER**

If the bidder is a manufacturer of the offered item(s), then they must satisfy the following criteria for manufacturing and supply experience and furnish the relevant documentary evidence as per below along with the technical bid:

**2.A.i** They must have an experience of minimum 5 (Five) years in manufacturing the quoted item(s) under relevant **API certification** as on the original bid closing date of the tender. Copies of relevant API certificates (having API authorization(s) for the item(s) mentioned in the tender) for the last 5 (Five) years (i.e., continuous without having any break in between) shall be submitted along with techno-commercial bid. Bids without copies of valid relevant API certificates or with break(s) in between will be rejected.

The bidder shall also submit an undertaking that they shall keep their API license valid till the execution of the Purchase Order.

Note: The above clause will be applicable only for those item(s) manufactured under API certifications, as specified in the tender.

**2.A.ii** The bidder should have manufactured and supplied minimum **01(one) number** of the tendered items, of same or higher grade /capacity/ rating and same or higher sizes, to any E&P companies/Drilling Contractors/Drilling service providers during last 5 (five) years as on original bid closing date of the tender (either by themselves or through their sole selling agent/ distributor/ dealer/supply house). Documentary evidence in respect of manufacturing and supplying the above-mentioned items should be submitted with the technical bid, in the form of copies of relevant signed and sealed Purchase Orders along with copies of any of the following documents in respect of satisfactory execution of each of those Purchase Orders failing which the bids will be rejected:

- I) Signed and sealed Satisfactory supply / completion / installation report (in original on user's letter head)
- (OR)
- II) Bill of Lading

(OR)

III) Consignee delivery receipt / challan

(OR)

IV) Central Excise Gate Pass/Tax Invoice issued under relevant rules of Central Excise/Vat.

(OR)

V) Commercial Invoice/ Payment Invoice

Note:

The Purchase Order date need not be within 5 (five) years preceding original bid closing date of this tender. However, the execution of supply should be within 5 (five) years preceding original bid closing date of this tender.

b) Satisfactory supply/completion/installation report should be issued on company's letterhead with signature and stamp.

**2.A.iii** Domestic manufacturer who has satisfactorily executed development order(s) placed by OIL/ONGCL for the tendered material (same or higher grade and same or higher outer diameter/rating/capacity) during recent years (i.e. during the last five years from the original bid closing date of this tender) shall also be considered as established sources for supply of the tendered item(s). Under such a situation, the bidder need not satisfy BRC clauses 2.A.i and 2.A. ii. But they must submit the following along with their techno-commercial bid:

i) Copy of relevant valid API certificate (as applicable)

ii) Copy of PO and successful Field Trial Report issued by OIL/ONGCL (bearing the PO No. & Date in their letter head), if executed against OIL/ONGCL's development order.

**2.A.iv** If the bidder is a manufacturer and has supplied minimum 01(one) number of the tendered item(s) (of same or higher capacity and same or higher sizes) to OIL during last 5 (five) years as on original bid closing date of the tender either by themselves or through their sole selling agent/distributor/dealer and whose past performance has been satisfactory, the bidder need not satisfy Clause 2.A. ii. In this situation the bidder shall have to indicate the Purchase Order (P.O.) Nos. of OIL in their technical bid.

## **2.B IN CASE THE BIDDER IS NOT A MANUFACTURER:**

If the bidder is a sole selling agent / distributor / dealer of the manufacturer of the tendered item(s), then bidder must furnish the following documents along with the technical bid failing which the bids will be rejected:

**2.B.i** Authorization certificate from the manufacturer (in original on manufacturer's letter head) should be submitted along with the technical bid. This certificate should be valid at the time of bidding and should remain valid during the entire execution period of the order.

**2.B.ii** Undertaking from the manufacturer (in original on manufacturer's letter head) guaranteeing supply of items to the bidder in the event of an order on the bidder. This certificate should be valid at the time of bidding and should remain valid during the entire execution period of the order.

**2.B.iii** Warranty backup from the manufacturer in original on manufacturer's letter head against the quality of the tendered item(s) as specified in the tender.

**2.B.iv** Documentary evidence in respect of manufacturer's experience in manufacturing under relevant API certification (if applicable) as specified under para 2.A.(i) from the concerned manufacturer.

**2.B.v** Documentary evidence in respect of manufacturer's supply experience as specified under para 2.A.(ii) from the concerned manufacturer (having supplied such items either by manufacturer themselves or through their sole selling agent / distributor / dealer).

**2.B.vi** Documentary evidence in respect of **bidder's own supply experience** of supplying minimum 01( one) number of the tendered items, of same or higher capacity and same or higher sizes, during last 5 (five) years as on original bid closing date of the tender as specified in the para 2.A.(ii).

**2.B.vii** If the bidder is sole selling agent / distributor / dealer of any manufacturer and has submitted bid of the manufacturer who has supplied minimum 01(one) of the tendered items (of same or higher capacity and same or higher sizes) **to OIL** during last 5 (five) years as on original bid closing date of the tender either by themselves or through their sole selling agent/distributor/dealer/supply house and whose past performance has been satisfactory, the manufacturer need not satisfy Clause 2.A.ii. In this situation, the bidder shall have to indicate the Purchase Order (PO) nos. of OIL executed by that manufacturer in their technical bid to substantiate the supply experience of the manufacturer. Such a bidder must meet Clause no. 2.B.vi above.

However, in case the bidder who is a sole selling agent / distributor / dealer himself has themselves supplied 01(one) number to OIL during last 5 (five) years as on original bid closing date of the tender, the bidder need not satisfy clause 2.B.vi. In this situation, the bidder shall have to indicate the Purchase Order (PO) nos. of OIL executed by that manufacturer in their technical bid.

**3.0 DELIVERY PERIOD:** Bidder should categorically confirm in the technical bid a delivery schedule within **Nine (09) months**, after receipt of formal order failing which, their offer will be rejected.

**(A.2) BRC - FINANCIAL:**

**1.0** The bidder must have an annual financial turnover from Operations of minimum **INR 73,61,966.00** during any of the preceding 3 (Three) financial/accounting years reckoned from the original bid closing date of the tender Audited Annual Reports.

*[Annual Financial Turnover of the bidder from Operations shall mean - "Aggregate value of the realization of amount made from the sale, supply or distribution of goods or on account of services rendered, or both, by the company (bidder) during a financial year" as per the Companies Act, 2013 Section 2 (91).]*

**2.0** "Net Worth" of the bidder must be positive for the financial/accounting year just preceding to the original Bid Closing Date of the Tender.

*[Net worth shall mean: "Share capital + Reserves created out of profits and securities Premium - Aggregate value of accumulated losses (excluding revaluation reserves) - deferred expenditure - Miscellaneous Expenditure to the extent not written off and carried forward loss - Reserves created out of write back of depreciation and amalgamation"]*

**3.0** Considering the time required for preparation of Financial Statements, if the last date of preceding financial/ accounting year falls within the preceding six months reckoned from the original bid closing date and the Financial Statements of the preceding financial/accounting year are not available with the bidder, then the financial turnover of the previous three financial/accounting years excluding the preceding financial/accounting year will be considered. In such cases, the Net worth of the previous financial/accounting year excluding the preceding financial/accounting year will be considered. However, the bidder has to submit an affidavit/ undertaking (**PROFORMA – A**) certifying that 'the balance sheet/Financial Statements for the financial year (as applicable) has actually not been audited so far'.

**Note:**

a) For proof of Annual Turnover & Net worth any one of the following document must be submitted along with the technical bid:-

i) A certificate issued by a practicing Chartered Cost Accountant (with Membership Number and Firm Registration Number), certifying the Annual Turnover & Net worth as per format prescribed in **(PROFORMA – B)**.

**OR**

ii) Audited Balance Sheet alongwith Profit & Loss account. In case of foreign bidders, self-attested/digitally signed printed published accounts are also acceptable.

b) In case the bidder is a Central Govt. Organization/PSU/State Govt. Organization/Semi-State Govt. Organization or any other Central/ State Govt. Undertaking, where the auditor is appointed only after the approval of Comptroller and Auditor General of India and the Central Government, their certificates may be accepted even though FRN is not available. However, bidder to provide documentary evidence for the same.

**4.0** In case the Audited Balance Sheet and Profit & Loss Account submitted along with the bid are in currencies other than INR or US\$, the bidder shall have to convert the figures in equivalent INR or US\$ considering the prevailing conversion rate on the date on which the Audited Balance Sheet and Profit & Loss Account is signed. A CA certificate is to be submitted by the bidder regarding converted figures in equivalent INR or US\$.

**5.0** In case the Bidder is subsidiary company (should be 100% owned subsidiary of the parent/ultimate parent/holding company) who does not meet financial criteria by itself and submits its bid based on the strength of parent/ultimate parent/holding company, then following documents need to be submitted:

(i) Turnover of the parent/ultimate parent/holding company should be in line with Para A.2 (1.0) above.

(ii) Net Worth of the parent/ultimate parent/holding company should be positive in line with Para A.2 (2.0) above.

(iii) Corporate Guarantee **(PROFORMA - C)** on parent/ultimate parent/holding company's company letter head signed by an authorized official undertaking that they would financially support their wholly owned subsidiary company for executing the project/job in case the same is awarded to them.

(iv) Documents to substantiate that the bidder is as 100% subsidiary of the parent/ultimate parent/holding company.

**(A.3) BRC - COMMERCIAL:**

**1.0** Bids are invited under **SINGLE STAGE TWO BID SYSTEM**. Bidders should upload Techno-Commercial Bid (Unpriced Bid) and Priced Bid separately at the designated fields assigned in GeM Portal. **Please note that no price details should be furnished in the Technical (i.e. Unpriced) bid.** The "Unpriced Bid" shall contain all techno-commercial details except the prices/costs. Bidder not complying with above submission procedure will be rejected.

**2.0** The prices/rates offered against the tender must remain firm through delivery and not subject to variation on any account. A bid submitted with an adjustable price condition shall be treated as non-responsive and rejected. No discount whatsoever should be quoted separately. Rates/prices quoted must be net of all discounts.

**3.0** Bids received in physical form shall be rejected (*except the documents specifically called for in hard copies, if any*). Also, modifications to bids received after the bid closing date & time shall not be entertained.

**4.0** Bids containing incorrect/false/misleading statement(s) shall be rejected.

- 5.0** Validity of the bid shall be **minimum 120 days** from the date of actual Bid Closing Date. Bids with lesser validity shall be straightway rejected.
- 6.0** Bidders must confirm that goods/materials to be supplied against the order arising out of this tender shall be of recent make, unused, of the best quality & workmanship and free from defects. The Bidder must undertake to stand guaranteed for the materials as called for in the tender. Defective goods/materials rejected by OIL, whether the entire lot or part thereof, shall be replaced immediately by the supplier at the supplier's expenses at no extra cost to OIL.
- 7.0** Successful bidder will be required to furnish a Performance Security **@5%** of the order value. The Performance Security must be valid for a period as called for in the tender document. Bidder must confirm the same in their Technical Bid. Offers not complying with this clause will be rejected. (Please refer Annexure – III: GENERAL NOTES TO BIDDERS)
- 8.0** Bids must be accompanied by Bid Security for the amount as mentioned in the tender document and shall be in the prescribed format (**PROFORMA – G**) if submitted in the form of Bank Guarantee (BG). **In case of the Bid Security is submitted in the form of Bank Guarantee, scanned copy of Bank Guarantee shall be uploaded by the bidder in the online bid and hard copy of the Bank Guarantee will have to be submitted directly to OIL within the Bid Closing (BC) date and time**, failing which the bid may be treated as incomplete and may lead to rejection of the bid by OIL without making any reference to the bidder. **Bid Security if submitted in the form of BG/e-BG must be valid till 07.09.2025**

Bid Security may also be paid through online payment mode. **Bid Security must be submitted within the scheduled Bid Closing date and time of the Tender**, failing which the bid may be treated as incomplete and may lead to rejection of the bid without making any reference to the bidder.

The amount of Bid Security (EMD) must be strictly as specified in the tender document. Bid shall be rejected without further reference, if the Bid Security (EMD) is not received strictly as above, except where exempted. OIL will not assume any responsibility whatsoever for submission of deficient/faulty Bid Security or for delay/non-delivery of the same (Please refer Annexure – III: GENERAL NOTES TO BIDDERS).

- 9.0** Bid must be uploaded together with the Integrity Pact (*If applicable against the tender*) and the same must be duly signed digitally. If any bidder refuses to sign Integrity Pact or declined to submit Integrity Pact, their bid shall be rejected straightway (Please refer Annexure – III: GENERAL NOTES TO BIDDERS).
- 10.0** Bidders shall accept and comply with the following clauses as given in the Bid Document, failing which bid shall be liable for rejection:
- i) Liquidated Damages
  - ii) Warranty/Guarantee of material
  - iii) Arbitration / Resolution of Dispute
  - iv) Force Majeure
  - v) Applicable Laws
- 11.0** A bid shall be rejected straightway if it does not conform to any one of the following clauses:
- a) Validity of bid shorter than the validity indicated in the Tender.
  - b) Incase the party refuses to sign Integrity Pact.
  - c) Original Bid Security not received within the stipulated date & time mentioned in the Tender.
  - d) Bid Security with (i) validity shorter than the validity indicated in Tender and/or (ii) Bid Security amount lesser than the amount indicated in the Tender.

## **ANNEXURE - III**

### **GENERAL NOTES TO BIDDERS**

- 1.0** The bid is governed by GeM General Terms & Conditions (GeM GTC) prevalent on the bid closing date of tender.
- 2.0** Bidders shall submit their offer mentioning pointwise compliance/noncompliance to all the terms & conditions, BEC/BRC, Specifications etc. Any deviation(s) from the tender terms & conditions, BEC/BRC, Specifications etc. should be clearly highlighted specifying justification in support of deviation.
- 3.0** To ascertain the substantial responsiveness of the bid, OIL reserves the right to ask the bidder for clarification in respect of clauses covered under BRC also and such clarifications fulfilling the BRC clauses in toto must be received on or before the deadline given by OIL, failing which the offer will be summarily rejected. However, bidder(s) must note that there should not be any additional financial involvement arising out of such post tender clarifications.
- 4.0** The Bidder to submit following Technical Evaluation Sheet along with technical bid -

Annexure –IV: Bid Evaluation Matrix (Technical Specification)

Annexure –V : Bid Evaluation Matrix (Bid Rejection Criteria)

**5.0 INTEGRITY PACT**

OIL shall be entering into an Integrity Pact, **if applicable** with the bidders as per format enclosed vide **PROFORMA - D** of the tender document. This Integrity Pact proforma has been duly signed digitally by OIL's competent signatory. The proforma has to be returned by the bidder (along with the technical bid) duly signed (digitally) by the same signatory who signed the bid, i.e., who is duly authorized to sign the bid. Uploading the Integrity Pact with digital signature will be construed that all pages of the Integrity Pact have been signed by the bidder's authorized signatory who sign the Bid. If any bidder refuses to sign Integrity Pact or declines to submit Integrity Pact with the offer, their bid shall be rejected straightway.

OIL's Independent External Monitors at present are as under:

DR. TEJENDRA MOHAN BHASIN,  
Former Vigilance Commissioner, CVC  
E-mail: tmbhasin@gmail.com

SHRI RAM PHAL PAWAR, IPS (Retd.),  
Former Director, NCRB, MHA  
E-mail: rpawar61@hotmail.com  
ramphal.pawar@ips.gov.in

SHRI AJIT MOHAN SHARAN, IAS (Retd.)  
Former Secretary, Ministry of Ayush, GoI  
Mob No.: 9810701876  
E-mail: ams057@gmail.com

- 5.1** In case of a joint venture, all the partners of the joint venture should sign the Integrity Pact.
- 5.2** In the event of any dispute between the management and the contractor relating to those contracts where Integrity Pact is applicable, in case, both the parties are agreeable, they may try to settle dispute through mediation before the panel of IEMs in a time bound manner. If required, the organizations may adopt any mediation rules for this purpose. In case, the dispute remains unresolved even after mediation by the panel of IEMs, the organisation may take further action as per the terms and conditions of the contract.
- 6.0 DOMESTICALLY MANUFACTURED IRON & STEEL PRODUCTS (DMI & SP): *Not Applicable***  
Steel Policy notified vide Notification No. 324 dated 29.05.2019 and as amended from time to time by Ministry of Steel, Government of India is applicable against this tender. The detailed policy may be referred in Ministry's website. Also, refer **ANNEXURE –VI** to this tender in this regard.

## **7.0 MICRO AND SMALL ENTERPRISES (MSE)**

Categorisation and various Criteria applicable to MSE bidders shall be guided by the Gazette Notification No. CG-DL-E-26062020-220191 dated 26.06.2020 and Amendment vide Gazette Notification no. CG-DL-E-16062021-227649 dated 16<sup>th</sup> June, 2021 issued by Ministry of Micro, Small and Medium Enterprises.

The bidder claiming as MSE status (MSE-General, MSE-SCIST, MSE -Woman) against this tender has to submit the following documents for availing the benefits applicable to MSEs:

### **Udyam Registration Number with Udyam Registration Certificate.**

**Note:** *In case bidding MSE is owned by Schedule Caste or Schedule Tribe entrepreneur or Woman Entrepreneur, valid documentary evidence issued by the agency who has registered the bidder as MSE owned by SC/ST entrepreneur/ Woman Entrepreneurs should also be enclosed.*

## **7.1 For availing benefits under Public Procurement Policy (Purchase preference), the interested MSE Bidders must ensure that they are the manufacturer of tendered item (Primary Product Category) and registered with the appropriate authority for the said item(s).**

## **8.0 PREFERENCE TO MAKE IN INDIA (MII)**

Department for Promotion of Industry and Internal Trade (DPIIT), has issued the revised 'Public Procurement (Preference to Make in India), Order 2017" vide Order no. No. P-45021/2/2017-PP (BE-II) dated 04.06.2020. Bidders are requested to go through the policy and its subsequent amendments, if any, and take note of the same while submitting their offer.

8.1 The 'Class-I local supplier'/ 'Class-II local supplier' at the time of tender, bidding or solicitation shall be required to **indicate percentage of local content and provide self-certification (PROFORMA – E) that the item offered meets the local content requirement for 'Class-I local supplier'/ 'Class-II local supplier', as the case may be.** They shall also give details of the location(s) at which the local value addition is made. Such undertaking shall become a part of the contract.

8.2 In cases of procurement **for a value in excess of Rs. 10 crores**, the 'Class-I local supplier'/ 'Class-II local supplier' shall be required to provide a certificate from the statutory auditor or cost auditor of the company (in the case of companies) or from a practicing cost accountant or practicing chartered accountant (in respect of suppliers other than companies) giving the percentage of local content.

## **9.0 RESTRICTIONS ON PROCUREMENT FROM A BIDDER OF A COUNTRY SHARING LAND BORDER WITH INDIA:**

Ministry of Finance of Govt. of India, Department of Expenditure, Public procurement Division vide office memorandum F. No. 6/18/2019-PPD dated 23rd July, 2020 (order-Public Procurement no.1) has proclaimed the insertion of Rule 144 (xi) in the General Financial Rules (GFRs), 2017 w.e.f. 23rd July, 2020 and amended vide O.M. No. F.7/10/2021-PPD (1) dated 23.02.2023 (order public procurement no. 4) from Procurement Policy Division, Department of Expenditure, Ministry of Finance forwarded by Department of Public Enterprises vide O.M. No. F. No. DPE/7 (4)/2017-Fin dated 24.02.2023 regarding restrictions on procurement from a bidder of a country which shares a land border with India on the grounds of defence of India on matters directly or indirectly related thereto including national security. Bidders are requested to take note of the following clauses and submit their offers accordingly wherever applicable.

- (1) Any bidder from a country which shares a land border with India will be eligible to bid in this tender only if the bidder is registered with the Competent Authority [Registration Committee constituted by the Department for Promotion of Industry and Internal Trade (DPIIT)]. Further, any bidder (including bidder from India) having specified Transfer of Technology (ToT) arrangement with an entity from a country which shares a land border with India, shall also require to be registered with the same competent authority to be eligible to bid in this tender.
- (2) "Bidder" (including the term 'tenderer', 'consultant' or 'service provider' in certain contexts) means any person or firm or company, including any member of a consortium or joint venture (that is an association of several persons, or firms or companies), every artificial juridical person not falling in any of the descriptions of bidders stated hereinbefore, including any agency branch or office controlled by such person, participating in a procurement process.

- (3) "Bidder (or entity) from a country which shares a land border with India" for the purpose of this Order means:
- a. An entity incorporated, established or registered in such a country; or
  - b. A subsidiary of an entity incorporated, established or registered in such a country; or
  - c. An entity substantially controlled through entities incorporated, established or registered in such a country; or
  - d. An entity whose beneficial owner is situated in such a country; or
  - e. An Indian (or other) agent of such an entity; or
  - f. A natural person who is a citizen of such a country; or
  - g. A consortium or joint venture where any member of the consortium or joint venture falls under any of the above

(4) The beneficial owner for the purpose of para (3) above will be as under:

- (i) In case of a company or Limited Liability Partnership, the beneficial owner is the natural person(s), who, whether acting alone or together, or through one or more juridical person, has a controlling ownership interest or who exercises control through other means.

Explanation:

- a. "Controlling ownership interest" means ownership of or entitlement to more than twenty-five percent of shares or capital or profits of the company.
  - b. "Control" shall include the right to appoint majority of the directors or to control the management or policy decisions including by virtue of their shareholding or management rights or shareholder's agreements or voting agreements.
- (ii) In case of a partnership firm, the beneficial owner is the natural person(s) who, whether acting alone or together, or through one or more juridical person, has ownership of entitlement to more than fifteen percent of capital or profits of the partnership;
- (iii) In case of an unincorporated association or body of individuals, the beneficial owner is the natural person(s), who, whether acting alone or together, or through one or more juridical person, has ownership of or entitlement to more than fifteen percent of the property or capital or profits of such association or body of individuals;
- (iv) Where no natural person is identified under (i) or (ii) or (iii) above, the beneficial owner is the relevant natural person who holds the position of senior managing official;
- (v) In case of a trust, the identification of beneficial owner(s) shall include identification of the author of the trust, the trustee, the beneficiaries with fifteen percent or more interest in the trust and any other natural person exercising ultimate effective control over the trust through a chain of control or ownership.

(5) An Agent is a person employed to do any act for another, or to represent another in dealings with third person.

(6) The successful bidder shall not be allowed to sub-contract works to any contractor from a country which shares a land border with India unless such contractor is registered with the Competent Authority.

(7) **Validity of Registration:** The registration should be valid at the time of submission of bid and at the time of acceptance of bid. If the bidder was validly registered at the time of acceptance/placement of order, registration shall not be a relevant consideration during contract execution.

(8) **Undertaking regarding compliance:** The bidders are required to provide undertakings as per **PROFORMA – F(I), PROFORMA – F(II) & PROFORMA – F(III)** along with their bid towards compliance of the above guidelines for participation in this tender. If the undertakings given by a bidder whose bid is accepted is found to be false, this would be a ground for debarment/action as per OIL's Banning Policy and further legal action in accordance with law.

## 10.0 SETTLEMENT OF DISPUTES:

10.1 **Arbitration (Applicable for Suppliers/Contractors other than PSU and MSME):** Except as otherwise provided elsewhere in the contract, if any dispute, difference, question or disagreement arises between the parties hereto or their respective representatives or assignees, in connection with construction, meaning, operation, effect, interpretation of the contract or breach thereof which parties are unable to settle mutually, the same shall be referred to Arbitration as provided hereunder.

10.1.1 A party wishing to commence arbitration proceeding shall invoke Arbitration Clause by giving 30 days' notice to the other party. The notice invoking arbitration shall specify all the points of dispute with details of the amount claimed to be referred to arbitration at the time of invocation of arbitration and not thereafter. If the claim is in foreign currency, the claimant shall indicate its value in Indian Rupee for the purpose of constitution of the arbitral tribunal.

10.1.2 It is agreed and undertaken by the Parties that irrespective of country of origin of the Contractor, the arbitration proceedings shall be governed by the Arbitration and Conciliation Act, 1996 and under no circumstances, the proceedings shall be construed as International Arbitration.

10.1.3 The number of arbitrators and the appointing authority will be as under:

Claim amount (excluding claim for interest and counter claim, if any)	Number of Arbitrator	Appointing Authority
Upto Rs. 25.00 Lakh	Not applicable	Not applicable
Above Rs. 25.00 Lakh upto Rs. 25 Crore	Sole Arbitrator	OIL
Above Rs. 25 Crore	3 Arbitrators	One Arbitrator by each party and the 3rd Arbitrator, who shall be the presiding arbitrator, by the two Arbitrators.

10.1.4 The parties agree that they shall appoint only those persons as arbitrators who accept the conditions of the arbitration clause. No person shall be appointed as Arbitrator or Presiding Arbitrator who does not accept the conditions of the arbitration clause.

10.1.5 If any of the Arbitrators so appointed dies, resigns, becomes incapacitated or withdraws for any reason from the proceedings, it shall be lawful for the concerned party/arbitrators to appoint another person in his place in the same manner as aforesaid. Such person shall proceed with the reference from the stage where his predecessor had left if both parties consent for the same; otherwise, he shall proceed de novo.

10.1.6 Parties agree and undertake that neither shall be entitled for any pre-reference or pendente-lite interest on its claims. Parties agree that any claim for such interest made by any party shall be void.

10.1.7 The arbitral tribunal shall complete the proceedings, make and publish the award within time stipulated in the Arbitration and Conciliation Act, 1996 (as amended).

10.1.8 If after commencement of the arbitration proceedings, the parties agree to settle the dispute mutually or refer the dispute to conciliation, the arbitrators shall put the proceedings in abeyance until such period as requested by the parties. Where the proceedings are put in abeyance or terminated on account of mutual settlement of dispute by the parties, the fees payable to the arbitrators shall be determined as under:

1. 20% of the fees if the claimant has not submitted statement of claim.
2. 40% of the fees if the pleadings are complete.
3. 60% of the fees if the hearing has commenced.

10.1.9 Each party shall be responsible to make arrangements for the travel and stay etc. of the arbitrator appointed by it. Claimant shall also be responsible for making arrangements for travel/stay arrangements of the Presiding Arbitrator and the expenses incurred shall be shared equally by the parties.

In case of sole arbitrator, both parties shall equally share all expenditures that may be required to be incurred.

10.1.10 The fees and other administrative/secretarial expenses of the arbitrator(s) shall not exceed the model fee as stipulated in Schedule of the Act and such expenses shall be equally borne by the parties.

10.1.11 The Place/Seat of Arbitration shall be Guwahati or the place where the contract is executed. The venue of the arbitration shall be decided by the Arbitrator(s) in discussion with the parties. The cost of arbitration sittings shall be equally borne by the parties.

10.1.12 The Arbitrator(s) shall give reasoned and speaking award and it shall be final and binding on the parties.

10.1.13 Subject to aforesaid, provisions of the Arbitration and Conciliation Act, 1996 and any statutory modifications or re-enactment thereof shall apply to the arbitration proceedings under this clause.

**10.2 Arbitration (applicable in case of Contract awarded on Public Sector Enterprise):**

10.2.1 In the event of any dispute or difference relating to the interpretation and application of the provisions of commercial contract (s) between Central Public Sector Enterprises (CPSEs) and also between CPSEs and Government Departments/Organizations (excluding disputes concerning Railways, Income Tax, Customs & Excise Departments), such dispute or difference shall be taken up by either party for resolution through AMRCD as mentioned in OPE OM No. 4(1)/2013-DPE(GM)/FTS-1835 dated 22-05-2018.

10.2.2 A party wishing to commence arbitration proceeding shall invoke Arbitration Clause and refer the dispute(s) to AMRCD with a copy to the other party. The notice invoking arbitration shall specify all the points of dispute with details of the amount claimed to be referred to arbitration at the time of invocation of arbitration and not thereafter.

10.2.3 Upon such reference, the dispute shall be decided by the Competent Authority appointed under the AMRCD, whose decision shall bind the parties finally and conclusively. The parties in the dispute will share equally the cost of the arbitration as intimated by the Arbitrator.

**10.3 Arbitration (Applicable to Micro, Small and Medium Enterprise)**

10.3.1 In the event of any dispute or difference relating to, arising from or connected with the Contract, efforts shall be made to resolve the dispute(s) amicably by mutual consultation and in case such dispute(s) cannot be resolved through mutual consultation, then same shall be resolved through the procedure as prescribed in Section-18 of the Micro, Small and Medium Enterprises Development Act, 2006.

**10.4 Resolution of disputes through conciliation by OEC**

*(Not Applicable in cases where value of dispute is less than Rs. 25 Lakhs and more than 2 Crore)*

If any dispute, difference, question or disagreement arises between the parties hereto or their respective representatives or assignees, in connection with construction, meaning, operation, effect, interpretation of the contract or breach thereof which parties are unable to settle mutually, Company at its discretion, on its own or on the request of the Contractor, may refer the dispute to Outside Expert Committee (OEC) to be constituted by Corporate Business Committee (CBC), OIL as provided hereunder –

10.4.1 The party desirous of resorting to conciliation shall send a notice of 30 (thirty) days to the other party of its intention of referring the dispute for resolution through OEC. The notice invoking conciliation shall specify all the points of disputes with details of the amount claimed to be referred to OEC and the party concerned shall not raise any new issue thereafter.

10.4.2 OIL shall nominate three outside experts, one each from Financial/commercial, Technical and Legal fields from the Panel of Outside Experts maintained by OIL who shall together be referred to as OEC (Outside Experts Committee).

10.4.3 Parties shall not claim any interest on claims/counterclaims from the date of notice invoking conciliation till execution of settlement agreement, if so, arrived at. In case, parties are unable to reach a settlement, no interest shall be claimed by either party for the period from the date of notice invoking conciliation till the date of OEC recommendations in any further proceeding.

10.4.4 The Proceedings of the OEC shall be broadly governed by Part III of the Arbitration and Conciliation Act, 1996 including any modifications thereof. Notwithstanding above, the proceedings shall be summary in nature and Parties agree to rely only upon documentary evidence in support of their claims and not to bring any oral evidence in the OEC proceedings.

- 10.4.5 OEC shall hear both the parties and recommend possible terms of settlement between the parties. The recommendations of OEC shall be non-binding and the parties may decide to accept or not to accept the same. Parties shall be at liberty to accept the OEC recommendation with any modification they may deem fit.
- 10.4.6 Where recommendations are acceptable to both the parties, a settlement agreement will be drawn up in terms of the OEC recommendations or with such modifications as may be agreed upon by the parties. The settlement agreement shall be signed by both the parties and authenticated by all the OEC members either in person or through circulation. This settlement agreement shall have the same legal status and effect as that of an arbitration award on agreed terms on the substance of the dispute rendered by an arbitral tribunal under Section 30 of the Arbitration and Conciliation Act, 1996.
- 10.4.7 OIL will share all other guidelines regarding reconciliation through OEC with the Contractor when it resorts to settlement through OEC. Both parties agree to adhere to these guidelines.
- 10.4.8 All the expenditure incurred in the OEC proceedings shall be shared by the parties in equal proportion. The parties shall maintain account of expenditure and present to the other for the purpose of sharing on conclusion of the OEC proceedings.
- 10.4.9 The OEC proceedings must be completed within a period of 3(three) months from the date of constitution of the OEC with a provision of extension of one months, subject to mutual agreement. The Place of OEC shall be either at New Delhi or Guwahati.
- 10.4.10 If the parties are not able to resolve the dispute through OEC or do not opt for conciliation through OEC, the party may invoke arbitration clause as provided in the contract.
- 10.4.11 The parties shall be represented by their in-house employees/executives. No party shall bring any advocate or outside consultant/advisor/agent. Ex-officers of OIL who have handled the matter in any capacity directly or indirectly shall not be allowed to attend and present the case before OEC on behalf of Contractor. However, ex-employees of parties may represent their respective organizations.
- 10.4.12 Solicitation or any attempt to bring influence of any kind on either OEC Members or OIL is completely prohibited in conciliation proceedings and OIL reserves the absolute right to close the conciliation proceedings at its sole discretion if it apprehends any kind of such attempt made by the Contractor or its representatives.

#### **10.5 Exclusions**

Parties agree that following matters shall not be referred to conciliation or arbitration:

- 10.5.1 Any claim, difference or dispute relating to, connected with or arising out of OIL's decision to initiate any proceedings or suspension or debarment or banning or decision to suspend or to ban or to debar business dealings with the bidder/Contractor and/or with any other person involved or connected or dealing with bid/contract/bidder/Contractor.
- 10.5.2 Any claim, difference or dispute relating to, connected with or arising out of OIL's decision under the provision of Integrity Pact executed between OIL and the Bidder/Contractor.
- 10.5.3 Any claim, difference or dispute relating to, connected with or arising out of OIL's decision to comply with any order or directive of any statutory or government authority.
- 10.5.4 Any claim which is less than Rs. 25 Lakh.

#### **11.0 TAX COLLECTIBLE AT SOURCE (TCS):**

Tax Collectible at Source (TCS) applicable under the Income-tax Law and charged by the SUPPLIER shall also be payable by OIL along with consideration for procurement of goods/materials/ equipment. If TCS is collected by the SUPPLIER, a TCS certificate in prescribed Form shall be issued by the SUPPLIER to OIL within the statutory time limit.

Payment towards applicable TCS u/s 206C (IH) of Income Tax Act, 1961 will be made to the supplier provided they are claiming it in their invoice and on submission of following undertaking along with the invoice stating that:

- a. TCS is applicable on supply of goods invoiced to OIL as turnover of the supplier in previous year was more than Rs. 10 Cr. And
- b. Total supply of goods to OIL in FY ..... (As applicable) exceeds Rs. 50 Lakh and
- c. TCS as charged in the invoice has already been deposited (duly indicating the details such as challan No. and date) or would be deposited with Exchequer on or before the due date and
- d. TCS certificate as provided in the Income Tax Act will be issued to OIL in time.

However, Performance Security deposit will be released only after the TCS certificate for the amount of tax collected is provided to OIL. Supplier will extend the performance bank guarantee (PBG), wherever required, till the receipt of TCS certificate or else the same will be forfeited to the extent of amount of TCS, if all other conditions of Purchase order are fulfilled.

The above payment condition is applicable only for release of TCS amount charged by supplier u/s 206C (I H) of Income tax Act, 1961.

**12.0 CONCESSIONAL GST**

The items covered in this Tender shall be used by Oil India Limited in the PEL/ML areas and hence concessional **GST @12%** will be applicable as per Govt. Policy in vogue.

**Note:** Successful bidder shall arrange to provide all necessary documents (invoice etc.) to OIL for applying Essentiality Certificate on receipt of request from OIL or at least **45 days** prior to their readiness for despatch, whichever is earlier. Further, successful bidder shall affect dispatch only on receipt of relevant certificates/shipment clearance from OIL, failing which all related liabilities shall be to supplier's account.

**13.0 APPLICABILITY OF BANNING POLICY OF OIL INDIA LIMITED:**

OIL's Banning Policy, 2023 will be applicable against the tender (and order in case of award) to deal with any agency (bidder/contractor/supplier/ vendor/service provider) who commits deception, default, fraud or indulged in other misconduct of whatsoever nature in the tendering process and/or order execution processes.

The bidders who are on Holiday/Banning/Suspension list of OIL on due date of submission of bid/ during the process of evaluation of the bids, the offers of such bidders shall not be considered for bid opening/evaluation/award. If the bidding documents were issued inadvertently/downloaded from website, the offers submitted by such bidders shall also not be considered for bid opening/evaluation/ Award of Work.

- 13.1 The bidder shall fill up and submit proforma of declaration of Blacklisting/Holiday Listing (**PROFORMA – G**) along with the technical bid.

**14.0 PERFORMANCE SECURITY**

Successful bidder will be required to furnish a **Performance Bank Guarantee @5%** of the order value with validity as mentioned in the tender document. The Performance Security must be submitted exactly as per **PROFORMA – H**. Bidder must confirm the same in their Technical Bid.

The Bank Guarantee issued by the bank must be routed through SFMS platform as per the following details:

- (i) MT 760/MT 760 COV for issuance of bank guarantee.
- (ii) MT 760/MT 767 COV for amendment of bank guarantee.

**[Order Number should reflect in the SFMS text under MT 760/MT 760 COV]**

The above message/intimation shall be sent through SFMS by the BG issuing Bank branch to ICICI Bank, Duliajan Branch, IFSC Code- ICIC0000213, Branch Address.: ICICI Bank Ltd, Kunja Bhavan, Daily Bazaar, Duliajan, Dibrugarh, Assam - 786602. The Bank details are as under:

<b>Bank Details of Beneficiary</b>	
Bank Name	ICICI BANK LTD.
Branch Name	DULIAJAN
Branch Address	KUNJA BHAVAN, DAILY BAZAAR, DULIAJAN, DIBRUGARH, ASSAM - 786602
IFSC Code	ICIC0000213
Unique identifier code (Field 7037)	OIL503988890
Company name	Oil India Limited

**The vendor shall submit to OIL the copy of the SFMS message as sent by the issuing bank branch along with the original bank guarantee.**

- 14.1 Performance Security shall be issued from any scheduled Indian Bank or any branch of an International Bank situated in India and registered with the Reserve Bank of India as scheduled foreign Bank in case of domestic suppliers.
- 14.2 Bank Guarantees issued by a Bank in India should be on non-judicial Stamp Paper/Frinking receipt of requisite value, as per Indian Stamp Act, purchased in the name of the Banker or the Seller.
- 14.3 Bank Guarantee with condition other than those mentioned in OIL's prescribed format shall not be accepted.
- 14.4 The Bank Guarantee issued by a Bank amongst others shall contain the complete address of the Bank including Phone Nos., Fax Nos., E-mail address, Code Nos. of the authorized signatory with full name and designation and Branch Code.
- 14.5 The Performance Security shall be payable to Purchaser as compensation for any breach or loss resulting from Supplier's failure to fulfil its obligations under the Purchase Order/Contract. In the event of such default on the part of Seller, the Performance Security shall be encashed unconditionally, and the proceeds thereof shall be forfeited without any further reference to the Seller. In such an eventuality, the Seller shall be liable to face penal actions including debarment as per OIL's Banning Policy, 2023.
- 14.6 The Performance Security shall be discharged by Purchaser not later than 30 days following its expiry after completion of obligations under the order/contract. In the event of any extension to the contractual validity or delay in supply/ execution or extension of Warranty Period of the Purchase Order/Contract, validity of the Performance Security shall be extended by the Seller/Contractor by the equivalent period.
- 14.7 The Performance Security shall not accrue any interest during its period of validity or extended validity. OIL shall not be liable to pay any bank charges, commission or interest on the amount of Performance Security.
- 14.8 Failure of the successful Bidder to comply with the requirements of above clauses shall constitute sufficient grounds for annulment of the award and forfeiture of their Bid Security or Performance Security. The defaulting party shall also be debarred from business as per OIL's Banning Policy, 2023.
- 14.9 In case, the Performance Security in the form of a Bank Guarantee is found to be not genuine or issued by a fake banker or issued under the fake signatures, the Purchase Order placed on the bidder shall be treated as cancelled forthwith and the bidder shall be banned from participating in future tenders in accordance with the provisions of Company's Banning Policy, 2023. Further, the Bid Security submitted by such bidder shall be invoked without any further reference, besides other penal action, as the Company may think appropriate.
- 14.10 In case Annual Maintenance Contract (AMC) is required and OIL intends to enter into a separate contract with the successful bidder for AMC, the Successful bidder must undertake to submit separate Performance Security against the AMC at the applicable rate & validity to be stipulated in the contract. (3% of annualized contract value valid for three months beyond entire execution period).
- 14.11 Performance Security if submitted in the form of fixed/term deposit; the following details must be provided in the form of declaration by the vendor/party for confirmation of Term deposit/Fixed Deposit from the issuing bank.
  1. Full address of the issuing bank
  2. Branch Code
  3. Authorized signatory with full name and designation
  4. Phone (Mobile) Numbers of the branch
  5. Email address of the branch
  6. Such fixed/term deposit must be pledged in favour of OIL and it must in the printed form on the physical original FDR in words "Pledged in favour of Oil India Limited"

Further, to avoid delay in confirmation of Fixed deposit from the issuing bank and consequent delay in processing of bills and payment, vendor/party may arrange the confirmation mail regarding issue of fixed

deposit with the following details directly from bank's official email id to OIL's following e-mail id (FD\_PS@OILINDIA.IN):

FD NO.	Issue Date	Maturity Date	FD Amount	Beneficiary/ Contractor Name	Whether above FD is pledged in favour of 'Oil India Limited' (Yes/No)	FD amount pledged (in ₹) as per bank's books of accounts	Mode of FD Renewal (Auto Renewal/ Auto closure)	Remarks (if any) of the issuing Bank
A	B	C	D	E	F	G	H	I

#### 15.0 BID SECURITY:

Bids must be accompanied by Bid Security for the amount as mentioned in the tender and shall be in the prescribed format (**PROFORMA – I**) as Bank Guarantee (BG) or Online payment. (*Refer GeM GTC for details*).

**In case of the Bid Security is submitted in the form of Bank Guarantee, scanned copy of Bank Guarantee shall be uploaded by the bidder in the online bid and hard copy of the Bank Guarantee will have to be submitted directly to OIL within the Bid Closing (BC) date and time**, failing which the bid may be treated as incomplete and may lead to rejection of the bid by OIL without making any reference to the bidder.

The Original Bid Security shall be submitted manually in sealed envelope **superscribed** with tender no., tendered item detail and due date to: **GM-MATERIALS, MATERIALS DEPARTMENT, KIND ATTENTION – Prayas Chakravorty, DGM MATERIALS, OIL INDIA LIMITED, DULIAJAN- 786602, ASSAM.**

In case of Online payment of Bid Security, bidder shall provide the Online transaction details in their online bid as proof of submission of Bid Security to OIL. The online payment of Bid Security amount should be received in OIL's bank account on or before the Bid closing date and time failing which the offer will be rejected outright without any further reference.

OIL's Bank account Details for Online submission of Bid Security	
Name	Oil India Limited
Bank	State Bank of India
Branch	Duliajan
Account Number	10494832599
Account Type	Current
IFSC Code	SBIN0002053

- 15.1 Bid Security shall be issued from any scheduled Indian Bank or any branch of an International Bank situated in India and registered with the Reserve Bank of India as scheduled foreign Bank in case of domestic suppliers.
- 15.2 Bank Guarantee issued by a scheduled Bank in India at the request of some other non-scheduled Bank in India shall not be accepted.
- 15.3 Bank Guarantees issued by a Bank in India should be on non-judicial Stamp Paper/Frinking receipt of requisite value, as per Indian Stamp Act, purchased in the name of the Banker or the Seller.
- 15.4 Bank Guarantee with condition other than those mentioned in OIL's prescribed format shall not be accepted.
- 15.5 The Bank Guarantee issued by a Bank amongst others shall contain the complete address of the Bank including Phone Nos., Fax Nos., E-mail address, Code Nos. of the authorized signatory with full name and designation and Branch Code.
- 15.6 The bidders will extend the validity of the Bid Security, if and whenever specifically advised by OIL, at the bidder's cost.
- 15.7 The Bid Security shall not accrue any interest during its period of validity or extended validity. OIL shall not be liable to pay any bank charges, commission or interest on the amount of Bid Security.
- 15.8 In case, the Bid Security in the form of a Bank Guarantee is found to be not genuine or issued by a fake banker or issued under the fake signatures, the bid submitted by the concerned bidder shall be rejected and

the bidder shall be banned from participating in future tenders in accordance with the provisions of OIL's Banning Policy. Further, the Bid Security submitted by such bidder shall be invoked without any further reference, besides other penal action, as OIL may think appropriate.

15.9 In case of Bank Guarantee, the Bank Guarantee issuing bank branch must ensure the following:

The Bank Guarantee issued by the bank must be routed through SFMS platform as per the following details:

- (i) MT 760/MT 760 COV for issuance of bank guarantee.
- (ii) MT 760/MT 767 COV for amendment of bank guarantee.

**[Tender Number should reflect in the SFMS text under MT 760/MT 760 COV]**

The above message/intimation shall be sent through SFMS by the BG issuing Bank branch to ICICI Bank, Duliajan Branch, IFSC Code- ICIC0000213, Branch Address: ICICI Bank Ltd, Kunja Bhavan, Daily Bazaar, Duliajan, Dibrugarh, Assam – 786602. The Bank details are as under:

<b>Bank Details of Beneficiary</b>	
Bank Name	ICICI BANK LTD.
Branch Name	DULIAJAN
Branch Address	KUNJA BHAVAN, DAILY BAZAAR, DULIAJAN, DIBRUGARH, ASSAM – 786602
IFSC Code	ICIC0000213
Unique identifier code (Field 7037)	OIL503988890
Company name	Oil India Limited

The bidder shall submit to OIL the copy of the SFMS message as sent by the issuing bank branch along with the original bank guarantee.

15.10 The Bid Security of the unsuccessful bidders will be returned after finalization of tender whereas the Bid Security of the successful bidder will be discharged on such bidder's furnishing the Performance Security to OIL against the Purchase Order secured by the bidder within the stipulated time frame. The successful bidder will, however, extend validity of the Bid Security till such time the Performance Security is furnished.

15.11 For timely return of Bid Security, bidders shall submit following details alongwith their technical bid.

- For Bank Guarantee((BG): Name, Email id, Phone number and Address where the Bid Security is to be returned by Courier.
- Online payment: Name, Email id, Phone number and Bank details (Bank Name, Branch Name, Branch Address, IFSC Code, Unique identifier code, Company name) where the Bid Security amount shall be returned by Online transfer.

In case of non-submission of above details, return of Bid Security may be delayed.

**\*\*NOTE TO PARA 14.0 AND 15.0 ABOVE:**

**Submission of Bid Security and Performance Security in the form of Electronic Bank Guarantee (e-BG)**

Oil India Ltd. has now adopted Electronic Bank Guarantee (e-BG) for Bid Security and Performance Security in addition to the existing provisions. Electronic Bank Guarantee (e-BG) is a digitally signed BG issued by banks which is transmitted directly from banks to beneficiaries in electronic form through a platform provided by National E-Governance Services Limited (NeSL).

Submission of Bid Security/Performance Security, as applicable, in the form of Electronic Bank Guarantee (e-BG) is also acceptable:

Sl. No.	Bank name	Sl. No.	Bank name
1	AU Small Finance Bank	12	IDFC First Bank
2	Axis Bank	13	Indian Bank
3	Bank of Baroda	14	Indian Overseas Bank
4	Bank of India	15	IndusInd Bank
5	Canara Bank	16	Karur Vysya Bank
6	City Union Bank	17	Kotak Mahindra Bank

Sl. No.	Bank name	Sl. No.	Bank name
7	Federal Bank	18	Punjab National Bank
8	HDFC Bank	19	RBL Bank
9	HSBC Bank	20	State Bank of India
10	ICICI Bank	21	South Indian Bank
11	IDBI Bank	22	Yes Bank

Beneficiary details for issue of e-BG are:

Sl. No.	Particulars	Details
1	Name	Oil India Limited
2	PAN	AAACO2352C
3	Date of Incorporation	18-02-1959
4	Email ID	
5	Mobile No.	
6	Local Address	
7	Registered Address	Duliaian, Dibrugarh, Assam-786602

**16.0 FINANCING OF TRADE RECEIVABLES OF MICRO AND SMALL ENTERPRISES (MSEs) THROUGH TRADE RECEIVABLES DISCOUNTING SYSTEM (TREDS) PLATFORM.**

Based on the initiatives of Government of India to help MSE vendors get immediate access to liquid fund based on Buyers credit rating by discounting, OIL has registered itself on TReDS platform with M/s RXIL and M/s A TREDS Ltd. (Invoice Mart). MSE vendors can avail this benefit by registering themselves with any of the exchanges providing e-discounting/electronic factoring services on TReDS platform and following the procedures defined therein, provided OIL is also participating in such TReDS Platform as a Buyer.

- i) MSE Vendor should be aware that all costs relating to availing the facility of discounting on TReDS platform including but not limited to Registration charges, Transaction charges for financing, Discounting Charges, Interest on financing, or any other charges known by any name shall be borne by MSE Vendor.
- ii) MSE Vendor hereby agrees to indemnify, hold harmless and keep OIL and its affiliates, Directors, officers, representatives, agents and employees indemnified, from any and all damages, losses, claims and liabilities (including legal costs) which may arise from Sellers submission, posting or display, participation, in any manner, on the TReDS Platform or from the use of Services or from the Buyer's breach of any of the terms and conditions of the Usage Terms or of this Agreement and any Applicable Law on a full indemnity basis.
- iii) OIL shall not be liable for any special, indirect, punitive, incidental, or consequential damages or any damages whatsoever (including but not limited to damages for loss of profits or savings, business interruption, loss of information), whether in contract, tort, equity or otherwise or any other damages resulting from using TReDS platform for discounting their (MSE Vendor's) invoices.

Note:

- (i) Buyer means OIL who has placed Purchase Order/ Contract on a MSE Vendor (Seller).
- (ii) Seller means a MSE vendor, who has been awarded Purchase Order/ Contract by OIL (Buyer).

**17.0 UNLOADING FOR BULKY/HEAVY ITEMS:**

All the Goods in the GeM shall be offered on Free Delivery at Site basis including unloading. **HOWEVER, OIL SHALL PROVIDE CRANE FOR UNLOADING OF BULKY/HEAVY ITEMS ONLY.** Supplier shall depute adequate crew, who has experience of unloading of such items at Destination (Duliajan) with necessary safety gears i.e. helmet, safety boots, hand gloves etc. at unloading point.

The safety of the crew deputed by the supplier shall entirely be the responsibility of supplier and therefore they shall take all necessary measures/precautions to ensure that no injuries occur to personnel or property. Supplier must ensure that the crew involved for unloading are properly trained on the procedures and aware of the potential hazards while handling the items.

**18.0 UNLOADING OF TUBULARS:**

All the Goods in the GeM shall be offered on Free Delivery at Site basis including unloading. **HOWEVER, OIL SHALL PROVIDE CRANE FOR UNLOADING OF TUBULARS ONLY.** Supplier shall depute adequate crew, who has experience of unloading of tubulars, at Destination (Duliajan) with necessary safety gears i.e. helmet, safety boots, hand gloves etc. at unloading point. **THE ONLY RESPONSIBILITY OF THE CREW TO BE DEPUTED BY THE SUPPLIER IS TO FASTEN/FIX CRANE'S HOOK SLING TO BUNDLES ON THE LOADED**

**VEHICLE.** Once the hook sling is securely fastened complying to the safety instructions, OIL's Crane shall lift and unload tubulars from the vehicle. Following points are to be noted and complied in this connection:

- (a) Supplier to ensure that height of the loaded tubular is below the cabin height of the vehicle for safe off-loading.
- (b) Supplier to ensure that tubular bundles are securely fastened by very strong material to withstand the rigors of road transportation and capable of lifting by Crane. In the case tubular bundles are found loosened and/or tubulars found completely resting on the side support/bales of vehicle in way that it may free fall upon unshackling, OIL will not unload such vehicle due to safety reasons.

The safety of the crew deputed by the supplier shall entirely be the responsibility of supplier and therefore they shall take all necessary measures/precautions to ensure that no injuries occur to personnel or property. Supplier must ensure that the crew involved for unloading are properly trained on the procedures and aware of the potential hazards while handling tubulars.

**19.0 UNLOADING OF CONSIGNMENT RECEIVED THROUGH RAIL:**

Unloading of consignment from Railway Wagons at Destination (**Duliajan**) shall be completely in OIL's scope.

**20.0 QUANTITY TOLERANCE FOR TUBULARS:**

Bidders should note that, in the event of order, quantity tolerance of +0%/-2% of order quantity will be applicable, if otherwise mentioned elsewhere in this document.

**21.0 SET-OFF:**

Any sum of money due and payable to the Seller (including Security Deposit refundable to them) under any purchase order may be appropriated by Oil India Limited and set-off against any claim of Oil India Limited (or such other person or persons contracting through Oil India Limited) for payment of a sum of money arising out of any other purchase order made by the Seller with Oil India Limited (or such other person or persons contracting through Oil India Limited).

**22.0 FURNISHING FRAUDULENT INFORMATION/ DOCUMENT:**

If it is found that a Bidder has furnished fraudulent document/information, the Bid Security/ Performance Security shall be forfeited and the party will be debarred for a period of 3(three) years from date of detection of such fraudulent act, besides the legal action. In case of major and serious fraud, period of debarment may be enhanced. In this regard, bidders are requested to submit an Undertaking as per **PROFORMA - J** along with their offer failing which their offer shall be liable for rejection.

**23.0 MODIFICATION/AMENDMENT OF TENDER DOCUMENT:** At any time prior to the deadline for submission of bids, the Company may, for any reason, whether at its own initiative or in response to a clarification requested by a prospective Bidder, modify the tender Documents through issuance of Corrigendum(s)/Addendum(s). Bidders are expected to take the Corrigendum(s)/ Addendum(s) into account in preparation and submission of their bid. No separate intimation for Corrigendum(s)/ Addendum(s) published by OIL shall be sent to the Bidders.

**24.0 GENERAL CONDITIONS OF CONTRACT FOR SERVICES (~~ANNEXURE – VII~~) *Not Applicable***

**General Conditions of Contract FOR SERVICES (GCC - SERVICES)** shall be applicable for all services to be rendered including AMC (as and when entered into).

**25.0 SIGNING OF BIDS:**

25.1 Bids are to be submitted online in GeM portal. The bid including all uploaded documents shall be signed by duly authorized representative of the bidder holding a Power of Attorney to bind the Bidder to the contract. The letter of authorisation (**PROFORMA-K**) shall be indicated by written Power of Attorney accompanying the Bid.

**26.0 BIDDERS FINANCIAL STANDING:**

The bidder should not be under liquidation, court receivership or similar proceedings and should not be bankrupt. Bidder to upload undertaking (**PROFORMA-L**) to this effect with bid.

**27.0 GENERAL HEALTH, SAFETY & ENVIRONMENT (HSE) GUIDELINES:**

27.1 It will be solely the Supplier's responsibility to fulfil all the legal formalities with respect to the Health, Safety and Environmental aspects of the entire job (namely; the person employed by him, the equipment,

the environment, etc.) under the jurisdiction of the district of that state where it is operating. Ensure that all sub-contractors, if any, hired by Supplier comply with the same requirement as the Supplier himself and shall be liable for ensuring compliance all HSE laws.

- 27.2 It will be entirely the responsibility of the Supplier/his Supervisor/ representative to ensure strict adherence to all HSE measures and statutory rules during operation in OIL's installations and safety of workers engaged by him. The crew members will not refuse to follow any instruction given by company's Installation Manager/Safety Officer/Engineer/Official/Supervisor/ Junior Engineer for safe operation.
- 27.3 Any compensation arising out of the job carried out by the Supplier whether related to pollution, Safety or Health will be paid by the Supplier only.
- 27.4 Any compensation arising due to accident of the Supplier's personnel while carrying out the job, will be payable by the Supplier.
- 27.5 When there is a significant risk to health, environment or safety of a person or place arising because of a non-compliance of HSE Measures, Company shall have the right to direct the Supplier to cease work until the non-compliance is corrected.

**28.0 DOCUMENTATION (FOR DOMESTIC/INDIGENOUS SUPPLIERS):**

- 28.1 Preparation and submission of proper documents by Seller is one of the very important requirements. The Seller must strictly follow the instructions.
- 28.2 Seller shall ensure that all the documents have clear reference of OIL's Purchase Order number.
- 28.3 Seller shall forward the documents, as mentioned below, by courier service immediately after the dispatch is made:

**1. WHERE PAYMENT AGAINST DIRECT SUBMISSION OF DESPATCH DOCUMENTS TO COMPANY:**

A)	General Manager (A/P), Finance & Accounts Department Oil India Limited, Duliajan, PIN - 786602	i) Bill in original + one copy. ii) Copy of the C-Note/RR. iii) Copy of Mill Inspection Certificate, if any. iv) Copy of Third-Party Inspection Certificate, if any. v) Copy of Delivery Challan. vi) Copy of TPI Declaration vii) Copy of Tax Invoice. viii) Copy of packing list. ix) Documentary evidence of payment of Customs Duty, if any.
B)	DGM - Materials (Receiving), Materials Department Oil India Limited, Duliajan, PIN - 786602	i) Clear Consignee copy of RR/C-Note-Original+1 copy. ii) Copy of Tax Invoice. iii) Delivery Challan (Original). iv) Packing list (Original). v) Mill inspection certificate, if any (Original). vi) Copy of Third-Party Inspection certificate, if any. vii) Copy of TPI Declaration viii) Warranty Certificate (Original)
C)	Chief Manager Materials (FP) Materials Department Oil India Limited, Duliajan, PIN - 786602	One set consisting copies of all the documents as mentioned in (B) above.

**Note:** Where payment is after receipt and acceptance of materials i.e. after CRAC, the complete set of documents meant for General Manager (A/P) as indicated in(A) above should be submitted to Dy. General Manager Materials (Receiving).

**PROFORMA – A**

**FORMAT FOR CERTIFICATE OF COMPLIANCE OF FINANCIAL CRITERIA**  
**(ON THE OFFICIAL PAD OF THE BIDDER TO BE EXECUTED BY THE AUTHORIZED SIGNATORY OF THE BIDDER)**

**Ref: Clause No. A.2 (3.0) - Financial Criteria of the BEC**

**Tender No.:** \_\_\_\_\_

I ..... the authorized signatory(s) of.....(Company or firm name of address) do hereby affirm and declare as under:-

The balance sheet/Financial Statements for the financial year \_\_\_\_\_ (as the case may be) has actually not been audited as on the Original Bid closing Date.

Place :.....

Date :.....

**Signature of the authorized signatory**

**Note:** *This certificate are to be issued only considering the time required for preparation of Financial Statements i.e. if the last date of preceding financial / accounting year falls within the preceding six months reckoned from the original bid closing date.*

**PROFORMA – B**

**CERTIFICATE OF ANNUAL TURNOVER & NETWORTH**

**TO BE ISSUED BY PRACTISING CHARTERED ACCOUNTANTS' FIRM ON THEIR LETTER HEAD**

**TO WHOM IT MAY CONCERN**

This is to certify that the following financial positions extracted from audited financial statements of M/s..... (Name of the bidder) for the last 3 (three) completed accounting years upto.....(as the case may be) are correct.

YEAR	TURNOVER In INR (Rs.) Crores/ USD Million*	NET WORTH In INR (Rs.) Crores / USD Million*

\*Rate of conversion (if used any): USD 1.00 = INR .....

Place:

Date:

Seal:

Membership No.:

Registration Code:

Signature:

***\*Applicable for Global Tenders.***

**NOTE: As per the guidelines of ICAI, every practicing CA is required to mention Unique Document Identification Number (UDIN) against each certification work done by them. Documents certified by CA without UDIN shall not be acceptable.**

**PROFORMA – C**

**PARENT/ ULTIMATE PARENT/ HOLDING COMPANY'S CORPORATE GUARANTEE TOWARDS FINANCIAL STANDING**

(Delete whichever not applicable)

(TO BE EXECUTED ON COMPANY'S LETTER HEAD)

**DEED OF GUARANTEE**

THIS DEED OF GUARANTEE executed at ..... this ..... day of ..... by M/s .....(mention complete name) a company duly organized and existing under the laws of ..... (insert jurisdiction/country), having its Registered Office at.....herein after called "the Guarantor" which expression shall, unless excluded by or repugnant to the subject or context thereof, be deemed to include its successors and permitted assigns.

WHEREAS M/s. Oil India Limited (hereinafter referred to as OIL) has invited offers vide their Tender No..... for.....and M/s.....(Bidder) intends to bid against the said tender and desires to have Financial support of M/s..... [Parent / Ultimate Parent/Holding Company(Delete whichever not applicable)] and whereas Parent/Ultimate Parent/Holding Company(Delete whichever not applicable) represents that they have gone through and understood the requirements of subject tender and are capable and committed to provide the Financial support as required by the bidder for qualifying and successful execution of the contract, if awarded to the bidder.

Now, it is hereby agreed by the Guarantor to give this Guarantee and undertakes as follows:

1. The Guarantor confirms that the Bidder is a 100% subsidiary of the Guarantor.
2. The Guarantor agrees and confirms to provide the Audited Annual Reports of any of the preceding 03(three) financial/accounting years reckoned from the original bid closing date.
3. The Guarantor have an annual financial turnover of minimum INR..... Cr or USD ..... during any of the preceding 03(three) financial/ accounting years reckoned from the original bid closing date.
4. Net worth of the Guarantor is positive for preceding financial/ accounting year.
5. The Guarantor undertakes to provide financial support to the Bidder for executing the project/job, in case the same is awarded to the Bidder.
6. The Guarantor represents that:
  - (a) this Guarantee herein contained shall remain valid and enforceable till the satisfactory execution and completion of the work (including discharge of the warranty obligations) awarded to the Bidder.
  - (b) the liability of the Guarantor, under the Guarantee, is limited to the 100% of the order value between the Bidder and OIL. This will, however, be in addition to the forfeiture of the Performance Guarantee furnished by the Bidder.
  - (c) this Guarantee has been issued after due observance of the appropriate laws in force in India.
  - (d) this Guarantee shall be governed and construed in accordance with the laws in force in India and subject to the exclusive jurisdiction of the courts of New Delhi, India.
  - (e) this Guarantee has been given without any undue influence or coercion, and that the Guarantor has fully understood the implications of the same.
  - (f) the Guarantor has the legal capacity, power and authority to issue this Guarantee and that giving of this Guarantee and the performance and observations of the obligations hereunder do not contravene any existing laws.

for and on behalf of (Parent/Ultimate Parent/  
Holding Company) (Delete whichever not applicable)

Witness:

- 1.
- 2.

for and on behalf of (Bidder)

Witness:

- 1.
- 2.

## **PROFORMA – D**

### **INTEGRITY PACT**

Between

Oil India Limited (OIL) hereinafter referred to as "The Principal"

And

(Name of the bidder).....hereinafter referred to as "The Bidder/Contractor"

#### **Preamble:**

The Principal intends to award, under laid down organizational procedures, contract/s for .....  
The Principal values full compliance with all relevant laws and regulations, and the principles of economic use of resources, and of fairness and transparency in its relations with its Bidder/s and Contractor/s.

In order to achieve these goals, the Principal cooperates with the renowned international Non-Governmental Organization "Transparency International" (TI). Following TI's national and international experience, the Principal will appoint an external independent Monitor who will monitor the tender process and the execution of the contract for compliance with the principles mentioned above.

#### **Section: 1 - Commitments of the Principal**

- (1) The Principal commits itself to take all measures necessary to prevent corruption and to observe the following principles:
- (i) No employee of the Principal, personally or through family members, will in connection with the tender for, or the execution of a contract, demand, take a promise for or accept, for him/herself or third person, any material or immaterial benefit which he/she is not legally entitled to.
  - (ii) The Principal will, during the tender process treat all Bidders with equity and reason. The Principal will in particular, before and during the tender process, provide to all Bidders the same information and will not provide to any Bidder confidential/additional information through which the Bidder could obtain an advantage in relation to the tender process or the contract execution.
  - (iii) The Principal will exclude from the process all known prejudiced persons.
- (2) If the Principal obtains information on the conduct of any of its employees which is a criminal offence under the relevant Anti-Corruption Laws of India, or if there be a substantive suspicion in this regard, the Principal will inform the Chief Vigilance Officers and in addition can initiate disciplinary actions.

#### **Section: 2 - Commitments of the Bidder/Contractor**

- (1) The Bidder/Contractor commits itself to take all measures necessary to prevent corruption. He commits himself to observe the following principles during his participation in the tender process and during the contract execution.
- (i) The Bidder/Contractor will not, directly or through any other person or firm, offer, promise or give to any of the Principal's employees involved in the tender process or the execution of the contract or to any third person any material or immaterial benefit which he/she is not legally entitled to, in order to obtain in exchange any advantage of any kind whatsoever during the tender process or during the execution of the contract.
  - (ii) The Bidder/Contractor will not enter with other Bidders into any undisclosed agreement or understanding, whether formal or informal. This applies in particular to prices, specifications, certifications, Subsidiary contracts, submission or non-submission of bids or any other actions to restrict competitiveness or to introduce cartelization in the bidding process.

- (iii) The Bidder (s) / Contractor (s) will not commit any offence under the relevant Anticorruption Laws of India, further, the Bidder (s) / Contractor (s) will not use improperly, for purposes of competition or personal gain, or pass on to others, any information or document provided by the Principal as part of the business relationship, regarding plans, technical proposals and business details, including information contained or transmitted electronically.
  - (iv) The Bidder/Contractor will, when presenting his bid, disclose any and all payments he has made, is committed to or intends to make to agents, brokers or any other intermediaries in connection with the award of the contract.
  - (v) Bidders to disclose any transgressions with any other company that may impinge on the anti-corruption principle.
  - (vi) The Bidder (s)/ Contractor (s) of foreign origin shall disclose the name and address of the Agents/ representatives in India, if any. Similarly, the Bidder (s)/ Contractor (s) of Indian Nationality shall furnish the name and address of the foreign principals, if any. Further, all the payments made to the Indian agent/ representative have to be in India Rupees only.
  - (vii) Bidders not to pass any information provided by Principal as part of business relationship to others and not to commit any offence under PC/ IPC Act;
- (2) The Bidder/Contractor will not instigate third persons to commit offences outlined above or be an accessory to such offences.
- (3) The Bidder/Contractor signing Integrity Pact shall not approach the Courts while representing the matters to IEMs and he/she will await their decision in the matter.

### **Section 3 - Disqualification from tender process and exclusion from future Contracts**

If the Bidder, before contract award has committed a transgression through a violation of Section 2 or in any other form such as to put his reliability or risibility as Bidder into question, the Principal is entitled to disqualify the Bidder from the tender process or to terminate the contract, if already signed, for such reason.

1. If the Bidder/Contractor has committed a transgression through a violation of Section 2 such as to put his reliability or credibility into question, the Principal is entitled also to exclude the Bidder/Contractor from future contract award processes. The imposition and duration of the exclusion will be determined by the severity of the transgression. The severity will be determined by the circumstances of the case, in particular the number of transgressions, the position of the transgressions within the company hierarchy of the Bidder and the amount of the damage. The exclusion will be imposed for a minimum of 6 months and maximum of 3 years.
2. The Bidder accepts and undertakes to respect and uphold the Principal's Absolute right to resort to and impose such exclusion and further accepts and undertakes not to challenge or question such exclusion on any ground, including the lack of any hearing before the decision to resort to such exclusion is taken. This undertaking is given freely and after obtaining independent legal advice.
3. If the Bidder/Contractor can prove that he has restored/recouped the Damage caused by him and has installed a suitable corruption prevention system, the Principal may revoke the exclusion prematurely.
4. A transgression is considered to have occurred if in light of available evidence no reasonable doubt is possible.
5. Integrity Pact, in respect of a particular contract, shall be operative from the date Integrity Pact is signed by both the parties till the final completion of the contract **or as mentioned in Section 9- Pact Duration whichever is later**. Any violation of the same would entail disqualification of the bidders and exclusion from future business dealings. Any issue relating to execution of contract, if specifically raised before the IEMs shall be looked into by IEMs.

#### **Section 4 - Compensation for Damages**

- (1) If the Principal has disqualified the Bidder from the tender process prior to the award according to Section 3, the Principal is entitled to demand and recover from the Bidder liquidated damages equivalent to Earnest Money Deposit / Bid Security.
- (2) If the Principal has terminated the contract according to Section 3, or if the Principal is entitled to terminate the contract according to Section 3, the principal shall be entitled to demand and recover from the Contractor liquidated damages equivalent to Security Deposit / Performance Bank Guarantee.
- (3) The bidder agrees and undertakes to pay the said amounts without protest or demur subject only to condition that if the Bidder/Contractor can prove and establish that the exclusion of the Bidder from the tender process or the termination of the contract after the contract award has caused no damage or less damage than the amount or the liquidated damages, the Bidder/Contractor shall compensate the Principal only to the extent of the damage in the amount proved.

#### **Section 5 - Previous transgression**

- (1) The Bidder declares that no previous transgression occurred in the last 3 years with any other Company in any country conforming to the TI approach or with any other Public Sector Enterprise in India that could justify his exclusion from the tender process.
- (2) If the Bidder makes incorrect statement on this subject, he can be disqualified from the tender process or the contract, if already awarded, can be terminated for such reason.

#### **Section: 6 - Equal treatment of all Bidders/Contractor/Subcontractors**

- (1) The Principal will enter into Pacts on identical terms with all bidders and contractors.
- (2) The Bidder / Contractor undertake(s) to procure from all subcontractors a commitment in conformity with this Integrity Pact. The Bidder/Contractor shall be responsible for any violation(s) of the provisions laid down in this agreement/Pact by any of its sub-contractors/sub-vendors.
- (3) The Principal will disqualify from the tender process all bidders who do not sign this Pact or violate its provisions.

#### **Section: 7 - Criminal charges against violating Bidders/Contractors/ Subcontractors**

If the Principal obtains knowledge of conduct of a Bidder, Contractor or Subcontractor, or of an employee or a representative or an associate of a Bidder, Contractor or Subcontractor, which constitutes corruption, or if the Principal has substantive suspicion in this regard, the Principal will inform the Vigilance Office.

#### **Section: 8 -External Independent Monitor/Monitors**

- (1) The Principal appoints competent and credible external independent Monitor for this Pact. The task of the Monitor is to review independently and objectively, whether and to what extent the parties comply with the obligations under this agreement.
- (2) The Monitor is not subject to instructions by the representatives of the parties and performs his functions neutrally and independently. He reports to the Chairperson of the Board of the Principal.
- (3) The Contractor accepts that the Monitor has the right to access without restriction to all Project documentation of the Principal including that provided by the Contractor. The Contractor will also grant the Monitor, upon his request and demonstration of a valid interest, unrestricted and unconditional access to his project documentation. The same is applicable to Subcontractors. The Monitor is under contractual obligation to treat the information and documents of the Bidder/Contractor/Subcontractor with confidentiality. However, the documents/records/information having National Security implications and those documents which have been classified as Secret/Top Secret are not to be disclosed.

- (4) The Principal will provide to the Monitor sufficient information about all meetings among the parties related to the Project provided such meetings could have an impact on the contractual relations between the Principal and the Contractor. The parties offer to the Monitor the option to participate in such meetings.
- (5) As soon as the Monitor notices, or believes to notice, a violation of this agreement, he will so inform the Management of the Principal and request the Management to discontinue or heal the violation, or to take other relevant action. The monitor can in this regard submit non-binding recommendations. Beyond this, the Monitor has no right to demand from the parties that they act in a specific manner, refrain from action or tolerate action. However, the Independent External Monitor shall give an opportunity to the bidder / contractor to present its case before making its recommendations to the Principal.
- (6) The Monitor will submit a written report to the Chairperson of the Board of the Principal within 8 to 10 weeks from the date of reference or intimation to him by the 'Principal' and, should the occasion arise, submit proposals for correcting problematic situations.
- (7) If the Monitor has reported to the Chairperson of the Board a Substantiated suspicion of an offence under relevant Anti-Corruption Laws of India, and the Chairperson has not, within reasonable time, taken visible action to proceed against such offence or reported it to the Vigilance Office, the Monitor may also transmit this information directly to the Central Vigilance Commissioner, Government of India.
- (8) The word 'Monitor' would include both singular and plural.
- (9) In case of any complaints referred under IP Program, the role of IEMs is advisory and would not be legally binding and it is restricted to resolving the issues raised by an intending bidder regarding any aspect of the tender which allegedly restricts competition or bias towards some bidder.

**Section: 9 - Pact Duration**

This Pact begins when both parties have legally signed it. It expires for the Contractor 12 months after the last payment under the respective contract, and for all other Bidders 6 months after the contract has been awarded.

If any claim is made/ lodged during this time, the same shall be binding and continue to be valid despite the lapse of this pact as specified above, unless it is discharged/determined by Chairperson of the Principal.

**Section: 10 - Other provisions**

- (1) This agreement is subject to Indian Law. Place of performance and jurisdiction is the Registered Office of the Principal. The Arbitration clause provided in the main tender document / contract shall not be applicable for any issue / dispute arising under Integrity Pact.
- (2) Changes and supplements as well as termination notices need to be made in writing. Side agreements have not been made.
- (3) If the Contractor / Bidder is a Joint Venture or a partnership concern or a consortium, this agreement must be signed by all partners or consortium members. In case of sub-contracting, the Principal contractor shall take the responsibility of the adoption of IP by the sub-contractor and all sub-contractors shall also sign the IP.
- (4) Should one or several provisions of this agreement turn out to be invalid, the remainder of this agreement remains valid. In this case, the parties will strive to come to an agreement to their original intentions.
- (5) Issues like warranty / guarantee, etc. shall be outside the purview of IEMs.

<p><b>Prayas Chakravorty</b>  .....  <b>For the Principal</b></p> <p>Date:  Place: Duliajan</p>	<p>.....  <b>For the Bidder/Contractor</b></p> <p>Witness 1: .....  Witness 2: .....</p>
---	--

**PROFORMA – E**

**UNDERTAKING FOR LOCAL CONTENT**  
*(To be submitted in the letter head of the bidder)*

We, \_\_\_\_\_ (Name of the bidder) have submitted Bid against Tender No. \_\_\_\_\_ dated \_\_\_\_\_ of Oil India Limited. We hereby undertake that we meet the mandatory minimum local content requirement as per the provision of Public Procurement (Preference to Make in India) Order, 2017 of Department for Promotion of Industry and Internal Trade (DPIIT), Govt. of India as revised vide Order No. P45021/2/2017-PP (BE-II) dated 16th September 2020 (and as amended time to time) with modifications as notified vide MoP&NG Order No. FP-20013/2/2017-FP-PNG-Part (4) (E-41432) dated 26th April 2022. The percentage of Local Content in the bid is \_\_\_\_\_ %.

For and on behalf of \_\_\_\_\_

Authorized signatory \_\_\_\_\_

Name \_\_\_\_\_

Designation \_\_\_\_\_

Contact No. \_\_\_\_\_

**NOTE:** *In cases of procurement **for a value in excess of Rs. 10 crores**, the 'Class-I local supplier'/ 'Class-II local supplier' shall be required to provide a certificate from the statutory auditor or cost auditor of the company (in the case of companies) or from a practicing cost accountant or practicing chartered accountant (in respect of suppliers other than companies) giving the percentage of local content.*

**PROFORMA – F(I)**

**UNDERTAKING TOWARDS COMPLIANCE OF PROVISIONS FOR RESTRICTIONS ON PROCUREMENT FROM A BIDDER  
OF A COUNTRY WHICH SHARES LAND BORDER WITH INDIA**

(To be typed on the letter head of the bidder)

Ref. No \_\_\_\_\_

Date: \_\_\_\_\_

Tender No. \_\_\_\_\_ Date: \_\_\_\_\_

**OIL INDIA LIMITED  
MATERIALS DEPARTMENT,  
DULIAJAN, ASSAM, INDIA**

**Dear Sirs,**

We, M/s \_\_\_\_\_, have read the clause regarding restrictions on procurement from a bidder of a country which shares a land border with India; we certify that we are not from such a country/or if from such a country, have been registered with the Competent Authority. We hereby certify that we fulfil all requirements in this regard and are eligible to be considered. *[wherever applicable, evidence of valid registration by the Competent Authority shall be attached]*

Yours faithfully,  
For (type name of the firm here)

Signature of Authorised Signatory

Name:

Designation:

Phone No.

Place:

Date:

(Affix Seal of the Organization here, if applicable)

**PROFORMA – F(II)**

**UNDERTAKING FOR WORKS INVOLVING POSSIBILITY OF SUB-CONTRACTING**

(To be typed on the letter head of the bidder)

Ref. No \_\_\_\_\_

Date: \_\_\_\_\_

Tender No. \_\_\_\_\_ Date: \_\_\_\_\_

**OIL INDIA LIMITED  
MATERIALS DEPARTMENT,  
DULIAJAN, ASSAM, INDIA**

**Dear Sirs,**

We, M/s \_\_\_\_\_, have read the clause regarding restrictions on procurement from a bidder of a country which shares a land border with India and on sub-contracting to contractors from such-countries, we certify that we are not from such a country/or if from such a country, have been registered with the Competent Authority and will not sub-contract any work to a contractor from such countries unless such contractor is registered with the Competent Authority. We hereby certify that we fulfil all requirements in this regard and is eligible to be considered. *[wherever applicable, evidence of valid registration by the Competent Authority shall be attached]*

Yours faithfully,  
For (type name of the firm here)

Signature of Authorized Signatory

Name:

Designation:

Phone No.

Place:

Date:

(Affix Seal of the Organization here, if applicable)

**PROFORMA – F(III)**

**ADDITIONAL UNDERTAKING BY BIDDER IN CASES OF SPECIFIED TRANSFER OF TECHNOLOGY**

(To be typed on the letter head of the bidder)

Ref. No \_\_\_\_\_

Date: \_\_\_\_\_

Tender No. \_\_\_\_\_ Date: \_\_\_\_\_

**OIL INDIA LIMITED  
MATERIALS DEPARTMENT,  
DULIAJAN, ASSAM, INDIA**

We, M/s \_\_\_\_\_, have read the clause regarding restrictions on procurement from a bidder having Transfer of Technology (ToT) arrangement. We certify that we do not have any ToT arrangement requiring registration with the competent authority.

OR

We, M/s \_\_\_\_\_, have read the clause regarding restrictions on procurement from a bidder having Transfer of Technology (ToT) arrangement. We certify that we have valid registration to participate in this procurement. *[Evidence of valid registration by the Competent Authority shall be attached]*

Yours faithfully,  
For (type name of the firm here)

Signature of Authorised Signatory

Name:

Designation:

Phone No.

Place:

Date:

(Affix Seal of the Organization here, if applicable)

**PROFROMA – G**

**PROFORMA OF DECLARATION OF BLACKLISTING / HOLIDAY LISTING**

**TO,**

**GM- MATERIALS  
MATERIALS DEPARTMENT  
P.O. DULIAJAN, PIN-786602  
DIST. DIBRUGARH, ASSAM, INDIA**

Dear Sir,

Sub: OIL's Tender No. \_\_\_\_\_

We hereby declare that we are presently neither placed on any holiday list or blacklist declared by OIL India Limited, nor any inquiry is pending by Oil India Limited in respect of corrupt or fraudulent practice.

It is understood that if this declaration is found to be false in any particular, Oil India Limited shall have the right to reject my/our bid, and if the bid has resulted in a contract, the contract is liable to be terminated without prejudice to any other right or remedy (include blacklisting or holiday listing) available to Oil India Limited.

For and on behalf of \_\_\_\_\_  
Authorized signatory \_\_\_\_\_  
Name \_\_\_\_\_  
Designation \_\_\_\_\_  
Contact No. \_\_\_\_\_

**PROFORMA – H**

**FORMATFORPERFORMANCEBANKGUARANTEE**

To,  
**GENERAL MANAGER – MATERIALS (HOD)**  
**OIL INDIA LIMITED, MATERIALS DEPARTMENT,**  
**DULIAJAN, ASSAM, INDIA, PIN – 786602**

WHEREAS.....(Name and address of Contractor)  
(hereinafter called “Contractor”) had undertaken, in pursuance of Contact No..... to  
execute (Name of Contract and Brief Description of the Work) .....  
(hereinafter called “the Contract”).

AND WHEREAS it has been stipulated by you in the said Contract that the Contractor shall furnish you with a Bank  
Guarantee as security for compliance with Contractor’s obligations in accordance with the Contract.

AND WHEREAS we ( May incorporate the Bank Name) have agreed to give the Contractor such a Bank Guarantee; NOW  
THEREFORE we hereby affirm that we are Guarantors on behalf of the Contractor, up to a total of (Amount of Guarantee  
in figures)..... (in words .....), such  
amount being payable in the types and proportions of currencies in which the Contract price is payable, and we  
undertake to pay you, upon your first written demand and without cavil or arguments, any sum or sums within the limits  
of guarantee sum as aforesaid without your needing to prove or to show grounds or reasons for your demand for the sum  
specified therein. We hereby waive the necessity of your demanding the said debt from the Contractor before presenting  
us with the demand.

We further agree that no change or addition to or other modification of the terms of the Contract or the work to be  
performed thereunder or of any of the Contract documents which may be made between you and the Contractor shall in  
any way cease us from any liability under this guarantee, and we hereby waive notice of such change, addition or  
modification.

This guarantee is valid until the .....day of.....

The details of the Issuing Bank and Controlling Bank are as under:

- A. Issuing Bank:  
BANK FAX NO:  
BANK EMAIL ID:  
BANK TELEPHONE NO:  
IFSC CODE OF THE BANK:
  
- B. Controlling Office:  
Address of the Controlling Office of the BG issuing Bank:  
Name of the Contract Person at the Controlling Office with Mobile No. and e-mail address:

Notwithstanding anything contained herein:

- (a) Our liability under this Bank Guarantee shall be restricted up to Rs.....
- (b) This guarantee shall be valid till .....
- (c) We are liable to pay the guarantee amount or any part thereof under this Bank Guarantee only and only if you  
serve upon us a written claim or demand on or before .....(Date of Expiry of BG PLUS  
one year claim period).
- (d) At the end of the claim period that is on or after.....(Date of expiry  
of.....the Bank Guarantee Plus Minimum of 1 year claim period shall be stipulated) all  
your rights under this Guarantee shall stand extinguished and we shall be discharged from all our liabilities  
under this Guarantee irrespective of receipt of original Bank Guarantee duly discharged, by Bank.

Name of the Contact Person at the Controlling Office with Mobile No. and e-mail address:

SIGNATURE AND SEAL OF THE GUARANTORS.....  
Designation:.....  
Name of the Bank:.....  
Address:.....

**UNDERTAKING BY VENDOR ON SUBMISSION OF BANK GUARANTEE**

To,

Oil India Limited,  
Materials Department,  
Duliajan, Assam - 786602

We, M/s..... are submitting the Bid Security/Performance Security (strike out whichever not applicable) in favour of Oil India Limited, Duliajan in the form of bank guarantee bearing Reference No.....for an amount of INR.....valid up to ..... as per terms and conditions of Tender / Contract No.....

**BG issuing bank details:**

Bank: Branch: IFS Code:	
<b>Contact Details</b> E-mail Addresses:	Mobile No.: Telephone No.: Fax No.:
<b>Correspondence Address</b> H No./Street/City:	State: Country: Pin Code:

**Declaration:**

We have arranged to send the confirmation of issuance of the bank guarantee via SFMS portal through our bank using the details mentioned in the tender and hereby confirming the correctness of the details mentioned.

Authorized Signature: \_\_\_\_\_  
Name: \_\_\_\_\_  
Vendor Code: \_\_\_\_\_  
Email ID: \_\_\_\_\_  
Mobile No.: \_\_\_\_\_

Enclosure: Original bank guarantee

**PROFORMA - I**

**BID SECURITY FORM**

To:  
M/s. OIL INDIA LIMITED,  
MATERIALS DEPARTMENT

Whereas.....(hereinafter called 'the Bidder') has submitted their Bid No. .... dated..... against OIL INDIA LIMITED, DULIAJAN, ASSAM, INDIA (hereinafter called the Purchaser) 's Tender No. ....for the supply of ..... (hereinafter called 'the Bid')KNOW ALL MEN by these presents.

That we .....of .....having our registered office at ..... (hereinafter called 'the Bank') are bound unto the Purchaser, in the sum of ..... for which payment well and truly to be made to the said Purchaser, the Bank binds itself, its successors and assigns by these presents.

Sealed with the said Bank this .....day of .....

THE CONDITIONS of this obligation are:

1. If the Bidder withdraws their Bid during the period of Bid validity specified by the Bidder,  
or
2. If the Bidder, having been notified of the acceptance of their bid by the Purchaser during the period of bid validity:
  - a) fails or refuses to accept the order; or
  - b) fails or refuses to furnish the performance securityor
3. If the Bidder furnishes fraudulent document/information in their bid.

We undertake to pay to the Purchaser up to the above amount upon receipt of their first written demand (by way of letter /fax/Email) without the Purchaser having to substantiate their demand, provided that in their demand the Purchaser will note that the amount claimed by it is due to it owing to the occurrence of any of the conditions, specifying the occurred condition or conditions.

This guarantee will remain in force up to and including ..... (Bidder to indicate specific date as mentioned in the tender), and any demand in respect thereof should reach the Bank not later than the above date.

The details of the Issuing Bank and Controlling Bank are as under:

A. Issuing Bank:

BANK FAX NO:  
BANK EMAIL ID:  
BANK TELEPHONE NO.:  
IFSC CODE OF THE BANK:

B. Controlling Office:

Address of the Controlling Office of the BG issuing Bank:  
Name of the Contact Person at the Controlling Office with Mobile No. and e-mail address:

Notwithstanding anything contained herein:

- a) Our liability under this Bank Guarantee shall be restricted up to Rs .....
- b) This guarantee shall be valid till .....
- c) We are liable to pay the guarantee amount or any part thereof under this Bank Guarantee only and only if you serve upon us a written claim or demand on or before ..... (Date of Expiry of BG PLUS one year claim period).
- d) At the end of the claim period that is on or after ..... (Date of expiry of the Bank Guarantee Plus Minimum of 1 year claim period shall be stipulated) all your rights under this Guarantee shall stand extinguished and we shall be discharged from all our liabilities under this Guarantee irrespective of receipt of original Bank Guarantee duly discharged, by Bank.

Name of the Contact Person at the Controlling Office with Mobile No. and e-mail address:

SIGNATURE AND SEAL OF THE GUARANTORS \_\_\_\_\_

Designation: \_\_\_\_\_

Name of Bank: \_\_\_\_\_

Address: \_\_\_\_\_

Date: \_\_\_\_\_

Place: \_\_\_\_\_

**PROFORMA - J**

**FORMAT OF UNDERTAKING BY BIDDERS TOWARDS SUBMISSION  
OF AUTHENTIC INFORMATION/DOCUMENTS**

**(To be typed on the letter head of the bidder)**

Ref. No \_\_\_\_\_

Date \_\_\_\_\_

To,

**General Manager (Materials)  
Materials Department  
Oil India Limited, Duliajan**

**Sub: Undertaking of authenticity of information/documents submitted**

**Ref: Your tender No. \_\_\_\_\_ Dated \_\_\_\_\_**

Sir,

With reference to our quotation no. .... dated..... against your above-referred tender, we hereby undertake that no fraudulent information/documents have been submitted by us.

We take full responsibility for the submission of authentic information/documents against the above cited bid.

We also agree that, during any stage of the tender/contract agreement, in case any of the information/documents submitted by us are found to be false/forged/fraudulent, OIL has right to reject our bid at any stage including forfeiture of our EMD and/or PBG and/or cancel the award of contract and/or carry out any other penal action on us, as deemed fit.

Yours faithfully,

For (type name of the firm here)

Signature of Authorised Signatory

Name:

Designation:

Phone No.

Place:

Date:

(Affix Seal of the Organization here, if applicable)

**PROFORMA – K**

**LETTER OF AUTHORITY**

TO,

**GM- MATERIALS  
MATERIALS DEPARTMENT  
P.O. DULIAJAN, PIN-786602  
DIST. DIBRUGARH, ASSAM, INDIA**

Dear Sir,

Sub: OIL's Tender No. \_\_\_\_\_

We \_\_\_\_\_ of \_\_\_\_\_  
confirm that Mr. \_\_\_\_\_ (Name and address) is  
authorised to represent us to Bid, negotiate and conclude the agreement on our behalf with you against OIL's  
Tender No. \_\_\_\_\_ for any commercial /Legal purpose etc.

We confirm that we shall be bound by all and whatsoever our said representative shall commit.

Authorised Person's Signature: \_\_\_\_\_

Name: \_\_\_\_\_

Designation: \_\_\_\_\_

Yours faithfully,

Signature: \_\_\_\_\_

Name & Designation: \_\_\_\_\_

For & on behalf of: \_\_\_\_\_

**Note:** *This letter of authority shall be on printed letter head of the Bidder and shall be signed by a person competent and having the power of attorney (power of attorney shall be annexed) to bind such Bidder.*

**PROFORMA – L**

**UNDERTAKING FOR BIDDERS FINANCIAL STANDING**

**TO,  
GM- MATERIALS  
MATERIALS DEPARTMENT  
P.O. DULIAJAN, PIN-786602  
DIST. DIBRUGARH, ASSAM, INDIA**

Dear Sir,

Sub: OIL's Tender No. \_\_\_\_\_

We, \_\_\_\_\_ (Name of the bidder) have submitted Bid against Tender No. \_\_\_\_\_ dated \_\_\_\_\_ of Oil India Limited. We hereby undertake that we are not under liquidation, court receivership or similar proceedings and we are not bankrupt.

For and on behalf of \_\_\_\_\_  
Authorized signatory \_\_\_\_\_  
Name \_\_\_\_\_  
Designation \_\_\_\_\_  
Contact No. \_\_\_\_\_

**PROFORMA – M**

**EXCEPTION / DEVIATION PROFORMA**

Oil India Limited expects the bidders to fully accept the terms and conditions of the bidding documents. However, should the bidder experience some exception and deviations to the terms of the bidding documents, the same should be indicated here and put in unpriced bid. In order to be considered responsive, Bidder's offer must specifically include the following statement:

(a) We certify that our offer complies with all NIT requirements and specifications without any deviations.

Or

(b) We certify that our offer complies with all NIT requirements and specifications with the following deviations:

Clause No. of Bidding Document	Full compliance/ not agreed	Exception/ deviations taken by the Bidders	Remarks

**Signature of the Bidder:** \_\_\_\_\_

**Name:** \_\_\_\_\_

**Seal of the company**

**PROFORMA – N**

**PROFORMA OF AUTHORISATION LETTER FOR ATTENDING TENDER OPENING**

Ref No.            Date:

**TO,  
GM- MATERIALS  
MATERIALS DEPARTMENT  
P.O. DULIAJAN, PIN-786602  
DIST. DIBRUGARH, ASSAM, INDIA**

Dear Sir,

Sub: OIL's Tender No. \_\_\_\_\_

I/We \_\_\_\_\_ confirm that Mr. \_\_\_\_\_ (Name and address) is  
authorized to represent us during bid opening on our behalf against Tender No. \_\_\_\_\_

Yours Faithfully,

Authorised Person's Signature: \_\_\_\_\_  
Name: \_\_\_\_\_  
Signature of Bidder: \_\_\_\_\_  
Name: \_\_\_\_\_  
Date: \_\_\_\_\_

**Note:** *This letter of authority shall be on printed letter head of the Bidder and shall be signed by a person who signs the bid.*

**ANNEXURE – IV**

**BID EVALUATION MATRIX (TECHNICAL SPECIFICATION)**

**TECHNICAL EVALUATION MATRIX**

**(TO BE FILLED IN BY BIDDER DULY SIGNED)**

**TECHNICAL SPECIFICATION**

<b>Clause Number</b>	<b>DESCRIPTION</b>	<b>BIDDER'S RESPONSE (Confirmed/Complied / Not Complied / Deviation / Not Applicable)</b>	<b>TO BE FILLED BY THE BIDDER</b>  Relevant Location of their Bid to support the remarks / compliance  (Reference of Document name / Serial number / Page number of bid for documentary evidence)
<b>1.0</b>	750 Short Ton Rated Weldless Elevator Links, designed, manufactured, tested, certified and monogrammed as per API specification 8C (latest edition), PSL-1, SR-1 and SR-3, as per the following specification:		

<p><b>A)</b></p>	<p><b>SPECIFICATIONS:</b></p> <ul style="list-style-type: none"> <li>i) Minimum Load Capacity : 750 Short Ton (150,00,00 lbs.)</li> <li>ii) Size : 4.3/4 inch (120.65 mm)</li> <li>iii) Length : 168 inch (4267.20 mm)</li> <li>iv) Product Specification Level : PSL-1</li> <li>v) Supplementary Requirement : SR-1 and SR-3</li> </ul>		
<p><b>B)</b></p>	<p><b>DESIGN FEATURES:</b></p> <ul style="list-style-type: none"> <li>i) Designed, Manufactured, Tested, Certified and Monogrammed as per API Spec. 8C (latest edition), PSL-1, SR-1 and SR-3</li> <li>ii) Suitable to hang elevators from top drive systems, hooks, beackets and link adaptors in on-shore drilling rigs</li> <li>iii) Forged construction from a single piece of high grade alloy steel</li> <li>iv) Operating environment: Standard</li> <li>v) Proof load tested as per API 8C, SR-1</li> </ul>		

<b>c)</b>	<p><b>DOCUMENTATION:</b></p> <p>The following documentation should be provided in English language along with the item.</p> <p>i) User Manual: 01(one) No.</p> <p>ii) Documentation consisting of Manufacturing Record Book as per SR-3 (API-8C latest edition), inclusive of Mill test certificate, Ultrasonic test reports, Proof load test report/certificate and subsequent examination reports (as applicable under SR-1 of API-8C latest edition) in Electronic/Hard copy format- 01(one) Set.</p>		
<b>D)</b>	<b>GENERAL NOTES TO BIDDERS</b>		
1)	<p>The item must be brand new, unused &amp; of prime quality. Bidder shall warrant (in the event of an order) that the product supplied will be free from all defects &amp; fault in material, workmanship &amp; manufacture and shall be in full conformity with ordered specifications. This clause shall be valid for 18 months from date of despatch/shipment or 12 months from the date of receipt at Duliajan, Assam, India whichever is earlier. The defective materials, if any, rejected by us shall be replaced by the supplier at their own expense. Bidders must confirm the same while quoting.</p>		
2)	<p>The Bidder should indicate the name of the manufacturer of the offered item in their quotation.</p>		

3)	The bidder must specify the offered item in details, forwarding relevant product catalogue, literature, detailed drawings with exploded views of each and every item of the offered product with complete spare parts list & clearly indicating the various parts with part numbers along with their quotation		
4)	The item is to be designed, manufactured, tested, certified and monogrammed as per API spec 8C (latest edition), PSL-1 & SR-1. Bidders are required to forward currently valid API Spec. 8C, PSL-1 certificate of the manufacturer along with the quotation.		
5)	The item shall be given a Proof Load Test as per API spec 8C (latest edition), SR-1 and certificate of Proof Load Test to be supplied along with the supply of item. Bidder should categorically confirm while quoting.		
6)	Necessary marking on the item shall be done as per API Spec. 8C (latest edition), PSL-1, SR-1 & SR3. Additionally, purchase order number and manufacturer's name have to be stamped on the body of the item. Bidder should categorically confirm while quoting.		
7)	In the event of order, the supply must include the manufacturing data/record book pertaining to the item as per API Spec. 8C (latest edition), SR-3 in hard copy format. Bidder should categorically confirm while quoting.		
8)	Bidder should note that in the event of an order, the API 8C, PSL-1 license for manufacturing the Link Block along with authorization for API monogramming should be valid, without any break, till execution of purchase order. Valid API 8C, PSL-1 certificate should be submitted along with the supply. Bidder should categorically confirm compliance while		

	quoting.		
9)	Any deviation(s) from the tender specification should be clearly highlighted specifying justification in support of deviation.		
10)	Bidder to sign and submit the completely filled up Technical check list and Technical Evaluation Matrix for Bid evaluation criteria and Technical specification along with the quotation.		

## CHECKLIST

1.0	Whether quoted as manufacturer?		
2.0	Whether quoted as OEM Dealer/Supply House?		
3.0	If quoted as OEM Dealer/Supply House -		
	a) Whether submitted valid and proper authorization letter from manufacturer confirming that bidder is their authorized Dealer/supply House for the product offered?		
	(b) Whether manufacturer's back-up Warranty/Guarantee certificate submitted?		
4.0	Whether agreed to the tender warranty clause of the tender?		
5.0	Whether submitted <b>EMD/Bid Security within the bid closing date and time</b> as per tender requirement?		
6.0	Whether quoted a firm delivery period as per the tender requirement?		
7.0	Whether confirmed to submit PBG as asked for in tender?		
8.0	Whether confirmed Bid Validity as per the tender requirement?		
9.0	Whether confirmed Payment Terms as per the tender?		
10.0	Whether quoted as MSE unit? If yes, whether necessary document submitted?		
11.0	Whether submitted Integrity Pact duly signed and sealed as per <b>PROFORMA – D</b> ?		
12.0	<p>Ministry of Finance of Govt. of India, Department of Expenditure, Public procurement Division vide office memorandum F. No. 6/18/2019-PPD dated 23rd July, 2020 (order-Public Procurement no.1) has proclaimed the insertion of Rule 144 (xi) in the General Financial Rules (GFRs), 2017 w.e.f. 23rd July, 2020 regarding restrictions on procurement from a bidder of a country which shares a land border with India on the grounds of defence of India on matters directly or indirectly related thereto including national security. Bidders are requested to take note of the office memorandum and submit their offers accordingly, wherever applicable.</p> <p>In this regard, bidders must submit duly sealed &amp; signed undertaking as per format provided vide, <b>PROFORMA – F(I), F(II) &amp; F(III)</b> along with the technical bid. Whether uploaded along with the bid?</p>		
13.0	Whether indicated the country of origin for the items quoted? Please mention the "Country of origin" under Remarks here.		
14.0	Whether submitted format of undertaking by bidders towards submission of authentic information/ documents as per <b>PROFORMA - J</b>		
15.0	Whether copy of the SFMS message for Bid Security/ EMD as sent by the issuing bank branch submitted along with the original bank guarantee?		
16.0	Whether certificate from the statutory auditor or cost auditor of the company submitted for Local Content. [Refer Para 8.2 of Annexure – III (General Notes to Bidder)]?		

**ANNEXURE – V**

**BID EVALUATION MATRIX (BID REJECTION CRITERIA)**

TECHNICAL EVALUATION MATRIX FOR BEC

(TO BE DULY FILLED IN BY BIDDER AND SIGNED)

BID EVALUATION CRITERIA

Clause Number	DESCRIPTION	BIDDER'S RESPONSE (TO BE FILLED BY THE BIDDER)	
		<u>(Confirmed/Complied / Not Complied / Deviation / Not Applicable)</u>	<u>Relevant Location of their Bid to support the remarks / compliance</u>  (Reference of Document name / Serial number / Page number of bid for documentary evidence)
	<b><u>BID EVALUATION CRITERIA/BID REJECTION CRITERIA</u></b>  The bids shall broadly conform to the specifications and terms and conditions given in this bid document. Bids shall be rejected in case the items offered do not conform to required parameters stipulated in the technical specifications and to the respective international/national standards wherever stipulated. Notwithstanding the general conformity of the bids to the stipulated specifications and terms and conditions, the following requirements will have to be particularly met by the Bidders without which the same will be considered as non-responsive and rejected.		
A	<b>BID REJECTION CRITERIA</b>		
<b>A.1</b>	<b>TECHNICAL:</b>		

	<b>The Items shall be manufactured &amp; tested as per relevant API norms as specified in the Tender (IF APPLICABLE). Bidder must confirm.</b>		
2.0	<b>EXPERIENCE</b>		
2.A	<p><b>MANUFACTURERS EXPERIENCE: IN CASE THE BIDDER IS THE MANUFACTURER:</b></p> <p>If the bidder is a manufacturer of the offered item(s), then they must satisfy the following criteria for manufacturing and supply experience and furnish the relevant documentary evidence as per below along with the technical bid:</p>		
<b>2.A.i</b>	<p>They must have an experience of minimum 5 (Five) years in manufacturing the quoted item(s) under relevant API certification as on the original bid closing date of the tender. Copies of relevant API certificates (having API authorization(s) for the item(s) mentioned in the tender) for the last 5 (Five) years (i.e., continuous without having any break in between) shall be submitted along with techno-commercial bid. Bids without copies of valid relevant API certificates or with break(s) in between will be rejected.</p> <p>The bidder shall also confirm that they shall keep their API license valid till the execution of the Purchase Order.</p> <p>Note: The above clause will be applicable only for those item(s) manufactured under API certifications, as specified in the tender.</p>		
<b>2.A.ii</b>	<p>The bidder should have manufactured and supplied minimum 01(one) number of the tendered items, of same or higher grade /capacity/ rating and same or higher sizes, to any E&amp;P companies/Drilling Contractors/Drilling service providers during last 5 (five) years as on original bid closing date of the tender (either by themselves or through their sole selling agent/ distributor/ dealer/supply house). Documentary evidence in respect of manufacturing and supplying the above-mentioned items should be submitted with the technical bid, in the form of copies of relevant signed and sealed Purchase Orders along with copies of any of the following documents in respect of satisfactory execution of each of those Purchase Orders failing which the bids will be rejected:</p> <p>I) Signed and sealed Satisfactory supply / completion / installation report (in original on user's letter head) (OR) II) Bill of Lading (OR)</p>		

	<p>III) Consignee delivery receipt / challan (OR) IV) Central Excise Gate Pass/Tax Invoice issued under relevant rules of Central Excise/Vat. (OR) V) Commercial Invoice/ Payment Invoice</p> <p>Note:</p> <p>a) The Purchase Order date need not be within 5 (five) years preceding original bid closing date of this tender. However, the execution of supply should be within 5 (five) years preceding original bid closing date of this tender.</p> <p>b) Satisfactory supply/completion/installation report should be issued on company's letterhead with signature and stamp.</p>		
<b>2.A.iii</b>	<p>manufacturer who has satisfactorily executed development order(s) placed by OIL/ONGCL for the tendered material (same or higher grade and same or higher outer diameter/rating/capacity) during recent years (i.e. during the last five years from the original bid closing date of this tender) shall also be considered as established sources for supply of the tendered item(s). Under such a situation, the bidder need not satisfy BRC clauses 2.A.i and 2.A. ii. But they must submit the following along with their techno-commercial bid:</p> <p>iii) Copy of relevant valid API certificate (as applicable)</p> <p>iv) Copy of PO and successful Field Trial Report issued by OIL/ONGCL (bearing the PO No. &amp; Date in their letter head), if executed against OIL/ONGCL's development order.</p>		
<b>2.A. iv</b>	<p>If the bidder is a manufacturer and has supplied minimum 01(one) number of the tendered item(s) (of same or higher capacity and same or higher sizes) to OIL during last 5 (five) years as on original bid closing date of the tender either by themselves or through their sole selling agent/distributor/dealer and whose past performance has been satisfactory, the bidder need not satisfy Clause 2.A. ii. In this situation the bidder shall have to indicate the Purchase Order (P.O.) Nos. of OIL in their technical bid.</p>		
<b>2.B</b>	<p><b>IN CASE THE BIDDER IS NOT A MANUFACTURER:</b></p> <p>If the bidder is a sole selling agent / distributor / dealer of the manufacturer of the tendered item(s), then bidder must furnish the following documents along with the technical bid failing which the bids will be rejected:</p>		

<b>2.B.i</b>	Authorization certificate from the manufacturer (in original on manufacturer's letter head) should be submitted along with the technical bid. This certificate should be valid at the time of bidding and should remain valid during the entire execution period of the order.		
<b>2.B.ii</b>	Undertaking from the manufacturer (in original on manufacturer's letter head) guaranteeing supply of items to the bidder in the event of an order on the bidder. This certificate should be valid at the time of bidding and should remain valid during the entire execution period of the order.		
<b>2.B.iii</b>	Warranty backup from the manufacturer in original on manufacturer's letter head against the quality of the tendered item(s) as specified in the tender.		
<b>2.B.iv</b>	Documentary evidence in respect of manufacturer's experience in manufacturing under relevant API certification (if applicable) as specified under para 2.A.(i) from the concerned manufacturer.		
<b>2.B.v</b>	Documentary evidence in respect of manufacturer's supply experience as specified under para 2.A.(ii) from the concerned manufacturer (having supplied such items either by manufacturer themselves or through their sole selling agent / distributor / dealer).		
<b>2.B.vi</b>	Documentary evidence in respect of <b>bidder's own supply experience</b> of supplying minimum 01(one) number of same or higher capacity and same or higher sizes, during last 5 (five) years as on original bid closing date of the tender as specified in the para 2.A.(ii).		
<b>2.B.vii</b>	<p>If the bidder is sole selling agent / distributor / dealer of any manufacturer and has submitted bid of the manufacturer who has supplied minimum 01(one) number of the tendered items (of same or higher capacity and same or higher sizes) to OIL during last 5 (five) years as on original bid closing date of the tender either by themselves or through their sole selling agent/distributor/dealer/supply house and whose past performance has been satisfactory, the manufacturer need not satisfy Clause 2.A.ii. In this situation, the bidder shall have to indicate the Purchase Order (PO) nos. of OIL executed by that manufacturer in their technical bid to substantiate the supply experience of the manufacturer. Such a bidder must meet Clause no. 2.B.vi above.</p> <p>However, in case the bidder who is a sole selling agent / distributor / dealer himself has themselves supplied 01(one) number to OIL during last 5 (five) years as on original bid closing date of the tender, the bidder need not satisfy clause 2.B.vi. In this situation, the bidder shall have to indicate the Purchase Order (PO) nos. of OIL executed by that manufacturer in their technical bid.</p>		
<b>3.0</b>	<b>DELIVERY PERIOD:</b> Bidder should categorically confirm in the technical bid a delivery schedule within nine (09) months, after receipt of formal order failing which, their offer will be rejected.		
<b>A.2</b>	<b>BRC - FINANCIAL:</b>		
<b>1.0</b>	The bidder must have an annual financial turnover from Operations of minimum <b>INR 73,61,966.00 during</b> any of the preceding 3 (Three) financial/accounting years reckoned from the original bid closing date of the tender Audited Annual Reports.		

	<i>[Annual Financial Turnover of the bidder from Operations shall mean - "Aggregate value of the realization of amount made from the sale, supply or distribution of goods or on account of services rendered, or both, by the company (bidder) during a financial year" as per the Companies Act, 2013 Section 2 (91). ]</i>		
<b>2.0</b>	<p>"Net Worth" of the bidder must be positive for the financial/accounting year just preceding to the original Bid Closing Date of the Tender.</p> <p><i>[Net worth shall mean: "Share capital + Reserves created out of profits and securities Premium - Aggregate value of accumulated losses (excluding revaluation reserves) - deferred expenditure - Miscellaneous Expenditure to the extent not written off and carried forward Loss - Reserves created out of write back of depreciation and amalgamation"]</i></p>		
<b>3.0</b>	<p>Considering the time required for preparation of Financial Statements, if the last date of preceding financial/accounting year falls within the preceding six months reckoned from the original bid closing date and the Financial Statements of the preceding financial/accounting year are not available with the bidder, then the financial turnover of the previous three financial/accounting years excluding the preceding financial/accounting year will be considered. In such cases, the Net worth of the previous financial/accounting year excluding the preceding financial/accounting year will be considered. However, the bidder has to submit an affidavit/ undertaking (<b>PROFORMA - A</b>) certifying that 'the balance sheet/Financial Statements for the financial year (as applicable) has actually not been audited so far'.</p> <p><b>Note:</b></p> <p>a) For proof of Annual Turnover &amp; Net worth any one of the following document must be submitted along with the technical bid:-</p> <p>i) A certificate issued by a practicing Chartered Cost Accountant (with Membership Number and Firm Registration Number), certifying the Annual Turnover &amp; Net worth as per format prescribed in (<b>PROFORMA – B</b>)</p> <p style="text-align: center;">OR</p> <p>ii) Audited Balance Sheet alongwith Profit &amp; Loss account. In case of foreign bidders, self-attested/digitally signed printed published accounts are also acceptable.</p> <p>b) In case the bidder is a Central Govt. Organization/PSU/State Govt. Organization/Semi-State Govt. Organization or any other Central/ State Govt. Undertaking, where the auditor is appointed only after the approval of Comptroller and Auditor General of India and the Central Government, their certificates may be accepted even though FRN is not available. However, bidder to provide documentary evidence for the same.</p>		
<b>4.0</b>	In case the Audited Balance Sheet and Profit & Loss Account submitted along with the bid are in currencies other than INR or US\$, the bidder shall have to convert the figures in equivalent INR or US\$ considering the prevailing conversion rate on the date on which the Audited Balance Sheet and Profit & Loss Account is signed. A CA certificate is to be submitted by the bidder regarding converted figures in equivalent INR or		

	US\$.		
<b>5.0</b>	<p>In case the Bidder is subsidiary company (should be 100% owned subsidiary of the parent/ultimate parent/holding company) who does not meet financial criteria by itself and submits its bid based on the strength of parent/ultimate parent/holding company, then following documents need to be submitted:</p> <p>(i) Turnover of the parent/ultimate parent/holding company should be in line with Para A.2 (1.0) above.</p> <p>(ii) Net Worth of the parent/ultimate parent/holding company should be positive in line with Para A.2 (2.0) above</p> <p>(iii) Corporate Guarantee (<b>PROFORMA - C</b>) on parent/ultimate parent/holding company's company letter head signed by an authorized official undertaking that they would financially support their wholly owned subsidiary company for executing the project/job in case the same is awarded to them.</p> <p>(iv) Documents to substantiate that the bidder is as 100% subsidiary of the parent/ultimate parent/holding company.</p>		
<b>A.3</b>	<b>BRC - COMMERCIAL</b>		
<b>1.0</b>	Bids are invited under <b>SINGLE STAGE TWO BID SYSTEM</b> . Bidders should upload Techno-Commercial Bid (Unpriced Bid) and Priced Bid separately at the designated fields assigned in GeM Portal. <b>Please note that no price details should be furnished in the Technical (i.e. Unpriced) bid.</b> The "Unpriced Bid" shall contain all techno-commercial details except the prices/costs. Bidder not complying with above submission procedure will be rejected.		
<b>2.0</b>	The prices/rates offered against the tender must remain firm through delivery and not subject to variation on any account. A bid submitted with an adjustable price condition shall be treated as non-responsive and rejected. No discount whatsoever should be quoted separately. Rates/prices quoted must be net of all discounts.		
<b>3.0</b>	Bids received in physical form shall be rejected ( <i>except the documents specifically called for in hard copies, if any</i> ). Also, modifications to bids received after the bid closing date & time shall not be entertained.		
<b>4.0</b>	Bids containing incorrect/false/misleading statement(s) shall be rejected.		
<b>5.0</b>	Validity of the bid shall be <b>minimum 120 days</b> from the date of actual Bid Closing Date. Bids with lesser validity shall be straightway rejected.		
<b>6.0</b>	Bidders must confirm that goods/materials to be supplied against the order arising out of this tender shall be of recent make, unused, of the best quality & workmanship and free from defects. The Bidder must undertake to stand guaranteed for the materials as called for in the tender. Defective goods/materials rejected by OIL, whether the entire lot or part thereof, shall be replaced immediately by the supplier at the supplier's expenses at no extra cost to OIL.		
<b>7.0</b>	Successful bidder will be required to furnish a Performance Bank Guarantee @5% of the order value. The Performance Security must be valid for a period as called for in the tender document. Bidder must confirm the same in their Technical Bid. Offers not complying with this clause will be rejected. (Please refer Annexure – III: GENERAL NOTES TO BIDDERS)		
<b>8.0</b>	Bids must be accompanied by Bid Security for the amount as mentioned in the tender document and shall be in the prescribed format ( <b>PROFORMA – I</b> ) if submitted in the form of Bank Guarantee (BG). <b><u>In case of the Bid Security is submitted in the form of Bank Guarantee, scanned copy of Bank Guarantee shall be</u></b>		

	<p><b><u>uploaded by the bidder in the online bid and hard copy of the Bank Guarantee will have to be submitted directly to OIL within the Bid Closing (BC) date and time</u></b>, failing which the bid may be treated as incomplete and may lead to rejection of the bid by OIL without making any reference to the bidder. <b>Bid Security if submitted in the form of BG/e-BG must be valid till 07.09.2025.</b></p> <p>Bid Security may also be paid through online payment mode. <b>Bid Security must be submitted within the scheduled Bid Closing date and time of the Tender</b>, failing which the bid may be treated as incomplete and may lead to rejection of the bid without making any reference to the bidder.</p> <p>The amount of Bid Security (EMD) must be strictly as specified in the tender document. Bid shall be rejected without further reference, if the Bid Security (EMD) is not received strictly as above, except where exempted. OIL will not assume any responsibility whatsoever for submission of deficient/faulty Bid Security or for delay/non-delivery of the same (Please refer Annexure – III: GENERAL NOTES TO BIDDERS).</p>		
<b>9.0</b>	Bid must be uploaded together with the Integrity Pact ( <i>If applicable against the tender</i> ) and the same must be duly signed digitally. If any bidder refuses to sign Integrity Pact or declined to submit Integrity Pact, their bid shall be rejected straightway. (Please refer Annexure – III: GENERAL NOTES TO BIDDERS)		
<b>10.0</b>	<p>Bidders shall accept and comply with the following clauses as given in the Bid Document, failing which bid shall be liable for rejection:</p> <ul style="list-style-type: none"> <li>i) Liquidated Damages</li> <li>ii) Warranty/Guarantee of material</li> <li>iii) Arbitration / Resolution of Dispute</li> <li>iv) Force Majeure</li> <li>v) Applicable Laws</li> </ul>		
<b>11.0</b>	<p>A bid shall be rejected straightway if it does not conform to any one of the following clauses:</p> <ul style="list-style-type: none"> <li>a) Validity of bid shorter than the validity indicated in the Tender.</li> <li>b) In case the party refuses to sign Integrity Pact.</li> <li>c) Original Bid Security not received within the stipulated date &amp; time mentioned in the Tender.</li> <li>d) Bid Security with (i) validity shorter than the validity indicated in Tender and/or (ii) Bid Security amount lesser than the amount indicated in the Tender</li> </ul>		

**XXXXXXXXXXXXXX**