

बिड दस्तावेज़ / Bid Document

बिड विवरण / Bid Details	
बिड बंद होने की तारीख/समय / Bid End Date/Time	07-01-2026 11:00:00
बिड खुलने की तारीख/समय / Bid Opening Date/Time	07-01-2026 11:30:00
बिड पेशकश वैधता (बंद होने की तारीख से) / Bid Offer Validity (From End Date)	90 (Days)
मंत्रालय/राज्य का नाम / Ministry/State Name	Ministry Of Petroleum And Natural Gas
विभाग का नाम / Department Name	Oil India Limited
संगठन का नाम / Organisation Name	Oil India Limited
कार्यालय का नाम / Office Name	Oil India Limited
कुल मात्रा / Total Quantity	21
वस्तु श्रेणी / Item Category	Title1 , Title2 , Title3 , Title4 , Title5
GeMARPTS में खोजी गई स्ट्रिंग्स / Searched Strings used in GeMARPTS	Mud Motor, Lubricator Assy, Rod Polished, Overshot
GeMARPTS में खोजा गया परिणाम / Searched Result generated in GeMARPTS	Category not available on GeM for the text string uploaded by the buyer
अधिसूचना के लिए चयनित प्रासंगिक श्रेणियाँ / Relevant Categories selected for notification	<ul style="list-style-type: none"> • Mud Balance
बीओक्यू शीर्षक / BOQ Title	BOQ for Materials
एमएसएमई के लिए अनुभव के वर्षों और टर्नओवर से छूट प्रदान की गई है / MSE Exemption for Years of Experience and Turnover	No
स्टार्टअप के लिए अनुभव के वर्षों और टर्नओवर से छूट प्रदान की गई है / Startup Exemption for Years of Experience and Turnover	No
विक्रेता से मांगे गए दस्तावेज़ / Document required from seller	Experience Criteria, Bidder Turnover, Certificate (Requested in ATC), OEM Authorization Certificate, OEM Annual Turnover, Additional Doc 1 (Requested in ATC), Additional Doc 2 (Requested in ATC), Additional Doc 3 (Requested in ATC), Additional Doc 4 (Requested in ATC), Compliance of BoQ specification and supporting document *In case any bidder is seeking exemption from Experience / Turnover Criteria, the supporting documents to prove his eligibility for exemption must be uploaded for evaluation by the buyer

बिड विवरण/Bid Details	
क्या आप निविदाकारों द्वारा अपलोड किए गए दस्तावेजों को निविदा में भाग लेने वाले सभी निविदाकारों को दिखाना चाहते हैं? संदर्भ मेनू है/Do you want to show documents uploaded by bidders to all bidders participated in bid?	No
बिड लगाने की समय सीमा स्वतः नहीं बढ़ाने के लिए आवश्यक बिड की संख्या। / Minimum number of bids required to disable automatic bid extension	1
दिनों की संख्या, जिनके लिए बिड लगाने की समय-सीमा बढ़ाई जाएगी। / Number of days for which Bid would be auto-extended	7
ऑटो एक्सटेंशन अधिकतम कितनी बार किया जाना है। / Number of Auto Extension count	1
बिड से रिवर्स नीलामी सक्रिय किया/Bid to RA enabled	No
बिड का प्रकार/Type of Bid	Two Packet Bid
प्राथमिक उत्पाद श्रेणी/Primary product category	Title1
तकनीकी मूल्यांकन के दौरान तकनीकी स्पष्टीकरण हेतु अनुमत समय /Time allowed for Technical Clarifications during technical evaluation	3 Days
निरीक्षण आवश्यक (सूचीबद्ध निरीक्षण प्राधिकरण /जेम के साथ पूर्व पंजीकृत एजेंसियों द्वारा)/Inspection Required (By Empanelled Inspection Authority / Agencies pre-registered with GeM)	No
Payment Timelines	Payments shall be made to the Seller within 30 days of issue of consignee receipt-cum-acceptance certificate (CRAC) and on-line submission of bills (This is in supersession of 10 days time as provided in clause 12 of GeM GTC)
मूल्यांकन पद्धति/Evaluation Method	Item wise evaluation/
वित्तीय दस्तावेज की आवश्यकता है / Financial Document Required	Yes
मध्यस्थता खंड/Arbitration Clause	No
सुलह खंड/Mediation Clause	No

ईएमडी विवरण/EMD Detail

एडवाइजरी बैंक/Advisory Bank	ICICI
Schedule 1 ईएमडी राशि/EMD Amount (In INR)	111500
Schedule 2 ईएमडी राशि/EMD Amount (In INR)	60500
Schedule 3 ईएमडी राशि/EMD Amount (In INR)	14000

Schedule 4 ईएमडी राशि/EMD Amount (In INR)	180000
Schedule 5 ईएमडी राशि/EMD Amount (In INR)	306000

ईपीबीजी विवरण /ePBG Detail

एडवाइजरी बैंक/Advisory Bank	ICICI
ईपीबीजी प्रतिशत (%) /ePBG Percentage(%)	5.00
ईपीबीजी की आवश्यक अवधि (माह) /Duration of ePBG required (Months).	22

(a). जेम की शर्तों के अनुसार ईएमडी छूट के इच्छुक बिडर को संबंधित केटेगरी के लिए बिड के साथ वैध समर्थित दस्तावेज प्रस्तुत करने है। एमएसई केटेगरी के अंतर्गत केवल वस्तुओं के लिए विनिर्माता तथा सेवाओं के लिए सेवा प्रदाता ईएमडी से छूट के पात्र हैं। व्यापारियों को इस नीति के दायरे से बाहर रखा गया है।/EMD EXEMPTION: The bidder seeking EMD exemption, must submit the valid supporting document for the relevant category as per GeM GTC with the bid. Under MSE category, only manufacturers for goods and Service Providers for Services are eligible for exemption from EMD. Traders are excluded from the purview of this Policy.

(b). The EMD Amount will be applicable for each schedule/group selected during Bid creation.

(c).ईएमडी और संपादन जमानत राशि, जहां यह लागू होती है, लाभार्थी के पक्ष में होनी चाहिए। / EMD & Performance security should be in favour of Beneficiary, wherever it is applicable.

लाभार्थी /Beneficiary :

GMFA

Oil India Limited, Duliagan, Assam 786602. Email : tuhin_roy@oilindia.in; Details of Beneficiary : OIL INDIA, Bank Name : ICICI BANK LTD, Branch Name :Duliagan, IFSC Code ICIC0000213, Unique identifier code (Field 7037) : OIL503988890, Company name : Oil India Limited Type of Account :Current (Gm Fa)

बोली विभाजन लागू नहीं किया गया/ Bid splitting not applied.

एमआईआई खरीद वरीयता / MII Purchase Preference

एमआईआई खरीद वरीयता / MII Purchase Preference	Yes
मेक इन इंडिया विक्रेताओं को खरीद में प्राथमिकता, यदि उनका मूल्य L1+X% तक की सीमा में है / Purchase Preference to MII sellers available upto price within L1+X%	20
मेक इन इंडिया खरीद में प्राथमिकता के लिए बिड की मात्रा का अधिकतम प्रतिशत / Maximum Percentage of Bid quantity for MII purchase preference	50

सार्वजनिक खरीद (मेक-इन-इंडिया को प्राथमिकता) आदेश 2017 के अनुसार केवल क्लास 1/क्लास 2 के स्थानीय आपूर्तिकर्ताओं को ही भागीदारी की अनुमति है दिनांक 16.09.2020 (समय-समय पर संशोधित एवं लागू) / Allow participation only from Class 1/Class 2 local suppliers as per the Public procurement(Preference to Make-in-india) order 2017 date 16.09.2020(as amended and applicable time to time)	Yes, in compliance with the MII ORDER : DPIIT Order(as amended and applicable time to time)
---	---

एमएसई खरीद वरीयता/MSE Purchase Preference

एमएसई खरीद वरीयता/MSE Purchase Preference	Yes
सूक्ष्म और लघु उद्यम मूल उपकरण निर्माताओं को खरीद में प्राथमिकता, यदि उनका मूल्य L1+X% तक की सीमा में हो / Purchase Preference to MSE OEMs available upto price within L1+X%	15
सूक्ष्म और लघु उद्यम को खरीद में प्राथमिकता के लिए बिड की मात्रा का अधिकतम प्रतिशत / Maximum Percentage of Bid quantity for MSE purchase preference	100

1. Preference to Make In India products (For bids < 200 Crore):Preference shall be given to Class 1 local supplier as defined in public procurement (Preference to Make in India), Order 2017 as amended from time to time and its subsequent Orders/Notifications issued by concerned Nodal Ministry for specific Goods/Products. The minimum local content to qualify as a Class 1 local supplier is denoted in the bid document. If the bidder wants to avail the Purchase preference, the bidder must upload a certificate from the OEM regarding the percentage of the local content and the details of locations at which the local value addition is made along with their bid, failing which no purchase preference shall be granted. In case the bid value is more than Rs 10 Crore, the declaration relating to percentage of local content shall be certified by the statutory auditor or cost auditor, if the OEM is a company and by a practicing cost accountant or a chartered accountant for OEMs other than companies as per the Public Procurement (preference to Make-in -India) order 2017 dated 04.06.2020. Only Class-I and Class-II Local suppliers as per MII order dated 4.6.2020 will be eligible to bid. Non - Local suppliers as per MII order dated 04.06.2020 are not eligible to participate. However, eligible micro and small enterprises will be allowed to participate .The buyers are advised to refer the OM No.F.1/4/2021-PPD dated 18.05.2023.

[OM No.1 4 2021 PPD dated 18.05.2023](#) for compliance of Concurrent application of Public Procurement Policy for Micro and Small Enterprises Order, 2012 and Public Procurement (Preference to Make in India) Order, 2017.

2. Purchase preference will be given to MSEs having valid Udyam Registration and whose credentials are validated online through Udyam Registration portal as defined in Public Procurement Policy for Micro and Small Enterprises (MSEs) Order, 2012 dated 23.03.2012 issued by Ministry of Micro, Small and Medium Enterprises and its subsequent Orders/Notifications issued by concerned Ministry. If the bidder wants to avail themselves of the Purchase preference, the bidder must be the manufacturer / OEM of the offered product on GeM. Traders are excluded from the purview of Public Procurement Policy for Micro and Small Enterprises and hence resellers offering products manufactured by some other OEM are not eligible for any purchase preference. In respect of bid for Services, the bidder must be the Service provider of the offered Service. Relevant documentary evidence in this regard shall be uploaded along with the bid in respect of the offered product or service and Buyer will decide eligibility for purchase preference based on documentary evidence submitted, while evaluating the bid. If L-1 is not an MSE and MSE Seller (s) has / have quoted price within L-1+ 15% (Selected by Buyer) of margin of purchase preference /price band defined in relevant policy, such MSE Seller shall be given opportunity to match L-1 price and contract will be awarded for 100% (selected by Buyer) percentage of total quantity. The buyers are advised to refer the OM No. F.1/4/2021-PPD dated 18.05.2023 [OM No.1 4 2021 PPD dated 18.05.2023](#) for compliance of Concurrent application of Public Procurement Policy for Micro and Small Enterprises Order, 2012 and Public Procurement (Preference to Make in India) Order, 2017. Benefits of MSE will be allowed only if seller is validated on-line in GeM profile as well as validated and approved by Buyer after evaluation of documents

submitted.

3. Estimated Bid Value indicated above is being declared solely for the purpose of guidance on EMD amount and for determining the Eligibility Criteria related to Turn Over, Past Performance and Project / Past Experience etc. This has no relevance or bearing on the price to be quoted by the bidders and is also not going to have any impact on bid participation. Also this is not going to be used as a criteria in determining reasonableness of quoted prices which would be determined by the buyer based on its own assessment of reasonableness and based on competitive prices received in Bid / RA process.

मूल्यांकन विधि(मदवार मूल्यांकन विधि) / Evaluation Method (Item Wise Evaluation Method)

Contract will be awarded schedulewise and the determination of L1 will be done separately for each schedule. The details of item-consignee combination covered under each schedule are as under:

मूल्यांकन अनुसूचियां / Evaluation Schedules	वस्तु/श्रेणी / Item/Category	मात्रा / Quantity
Schedule 1	Title1	2
Schedule 2	Title2	5
Schedule 3	Title3	8
Schedule 4	Title4	2
Schedule 5	Title5	4

Title1

(क्रमशः श्रेणी 1 और श्रेणी 2 के स्थानीय आपूर्तिकर्ता के रूप में अर्हता प्राप्त करने के लिए आवश्यक/Minimum 50% and 20% Local Content required for qualifying as Class 1 and Class 2 Local Supplier respectively)

तकनीकी विशिष्टियाँ /Technical Specifications

Specification Document	View File
BOQ Detail Document	View File

Advisory-Please refer attached BOQ document for detailed consignee list and delivery period.

परेषिती/रिपोर्टिंग अधिकारी तथा मात्रा/Consignees/Reporting Officer and Quantity

क्र.सं./S.N o.	परेषिती/रिपोर्टिंग अधिकारी /Consignee Reporting/Officer	पता/Address	मात्रा /Quantity	डिलीवरी के दिन/Delivery Days
1	Chandana Phukan	786602,Oil India Limited, Duliajan, Assam	2	180

Title2

(क्रमशः श्रेणी 1 और श्रेणी 2 के स्थानीय आपूर्तिकर्ता के रूप में अर्हता प्राप्त करने के लिए आवश्यक/Minimum 50% and 20% Local Content required for qualifying as Class 1 and Class 2 Local Supplier respectively)

तकनीकी विशिष्टियाँ /Technical Specifications

Specification Document	View File
BOQ Detail Document	View File

Advisory-Please refer attached BOQ document for detailed consignee list and delivery period.

परेषिती/रिपोर्टिंग अधिकारी तथा मात्रा/Consignees/Reporting Officer and Quantity

क्र.सं./S.N o.	परेषिती/रिपोर्टिंग अधिकारी /Consignee Reporting/Officer	पता/Address	मात्रा /Quantity	डिलीवरी के दिन/Delivery Days
1	Chandana Phukan	786602,Oil India Limited, Duliajan, Assam	5	180

Title3

(क्रमशः श्रेणी 1 और श्रेणी 2 के स्थानीय आपूर्तिकर्ता के रूप में अर्हता प्राप्त करने के लिए आवश्यक/Minimum 50% and 20% Local Content required for qualifying as Class 1 and Class 2 Local Supplier respectively)

तकनीकी विशिष्टियाँ /Technical Specifications

Specification Document	View File
BOQ Detail Document	View File

Advisory-Please refer attached BOQ document for detailed consignee list and delivery period.

परेषिती/रिपोर्टिंग अधिकारी तथा मात्रा/Consignees/Reporting Officer and Quantity

क्र.सं./S.N o.	परेषिती/रिपोर्टिंग अधिकारी /Consignee Reporting/Officer	पता/Address	मात्रा /Quantity	डिलीवरी के दिन/Delivery Days
1	Chandana Phukan	786602,Oil India Limited, Duliajan, Assam	8	180

Title4

(क्रमशः श्रेणी 1 और श्रेणी 2 के स्थानीय आपूर्तिकर्ता के रूप में अर्हता प्राप्त करने के लिए आवश्यक/Minimum 50% and 20% Local Content required for qualifying as Class 1 and Class 2 Local Supplier respectively)

तकनीकी विशिष्टियाँ /Technical Specifications

Specification Document	View File
BOQ Detail Document	View File

Advisory-Please refer attached BOQ document for detailed consignee list and delivery period.

परेषिती/रिपोर्टिंग अधिकारी तथा मात्रा/Consignees/Reporting Officer and Quantity

क्र.सं./S.N o.	परेषिती/रिपोर्टिंग अधिकारी /Consignee Reporting/Officer	पता/Address	मात्रा /Quantity	डिलीवरी के दिन/Delivery Days
1	Chandana Phukan	786602,Oil India Limited, Duliajan, Assam	2	150

Title5

(क्रमशः श्रेणी 1 और श्रेणी 2 के स्थानीय आपूर्तिकर्ता के रूप में अर्हता प्राप्त करने के लिए आवश्यक/Minimum 50% and 20% Local Content required for qualifying as Class 1 and Class 2 Local Supplier respectively)

तकनीकी विशिष्टियाँ /Technical Specifications

Specification Document	View File
BOQ Detail Document	View File

Advisory-Please refer attached BOQ document for detailed consignee list and delivery period.

परेषिती/रिपोर्टिंग अधिकारी तथा मात्रा/Consignees/Reporting Officer and Quantity

क्र.सं./S.N o.	परेषिती/रिपोर्टिंग अधिकारी /Consignee Reporting/Officer	पता/Address	मात्रा /Quantity	डिलीवरी के दिन/Delivery Days
1	Chandana Phukan	786602,Oil India Limited, Duliajan, Assam	4	150

क्रेता द्वारा जोड़ी गई बिड की विशेष शर्तें/Buyer Added Bid Specific Terms and Conditions

1. Generic

OPTION CLAUSE: The Purchaser reserves the right to increase or decrease the quantity to be ordered up to 25 percent of bid quantity at the time of placement of contract. The purchaser also reserves the right to increase the ordered quantity up to 25% of the contracted quantity during the currency of the contract at the contracted rates. The delivery period of quantity shall commence from the last date of original delivery order and in cases where option clause is exercised during the extended delivery period the additional time shall commence from the last date of extended delivery period. The additional delivery time shall be $(\text{Increased quantity} \div \text{Original quantity}) \times \text{Original delivery period (in days)}$, subject to minimum of 30 days. If the original delivery period is less than 30 days, the additional time equals the original delivery period. The Purchaser may extend this calculated delivery duration up to the original delivery period while exercising the option clause. Bidders must comply with these terms.

अस्वीकरण/Disclaimer

The additional terms and conditions have been incorporated by the Buyer after approval of the Competent Authority in Buyer Organization, whereby Buyer organization is solely responsible for the impact of these clauses on the bidding process, its outcome, and consequences thereof including any eccentricity / restriction arising in the bidding process due to these ATCs and due to modification of technical specifications and / or terms and conditions governing the bid. If any clause(s) is / are incorporated by the Buyer regarding following, the bid and resultant contracts shall be treated as null and void and such bids may be cancelled by GeM at any stage of bidding process without any notice:-

1. Definition of Class I and Class II suppliers in the bid not in line with the extant Order / Office Memorandum issued by DPIIT in this regard.
2. Seeking EMD submission from bidder(s), including via Additional Terms & Conditions, in contravention to exemption provided to such sellers under GeM GTC.
3. Publishing Custom / BOQ bids for items for which regular GeM categories are available without any Category item bunched with it.
4. Creating BoQ bid for single item.
5. Mentioning specific Brand or Make or Model or Manufacturer or Dealer name.
6. Mandating submission of documents in physical form as a pre-requisite to qualify bidders.
7. Floating / creation of work contracts as Custom Bids in Services.
8. Seeking sample with bid or approval of samples during bid evaluation process. (However, in bids for [attached categories](#), trials are allowed as per approved procurement policy of the buyer nodal Ministries)
9. Mandating foreign / international certifications even in case of existence of Indian Standards without specifying equivalent Indian Certification / standards.
10. Seeking experience from specific organization / department / institute only or from foreign / export experience.
11. Creating bid for items from irrelevant categories.
12. Incorporating any clause against the MSME policy and Preference to Make in India Policy.
13. Reference of conditions published on any external site or reference to external documents/clauses.
14. Asking for any Tender fee / Bid Participation fee / Auction fee in case of Bids / Forward Auction, as the case may be.
15. Buyer added ATC Clauses which are in contravention of clauses defined by buyer in system generated bid template as indicated above in the Bid Details section, EMD Detail, ePBG Detail and MII and MSE Purchase Preference sections of the bid, unless otherwise allowed by GeM GTC.
16. In a category based bid, adding additional items, through buyer added additional scope of work/ additional terms and conditions/or any other document. If buyer needs more items along with the main item, the same must be added through bunching category based items or by bunching custom catalogs or bunching a BoQ with the main category based item, the same must not be done through ATC or Scope of Work.

Further, if any seller has any objection/grievance against these additional clauses or otherwise on any aspect of this bid, they can raise their representation against the same by using the Representation window provided in the bid details field in Seller dashboard after logging in as a seller within 4 days of bid publication on GeM. Buyer is duty bound to reply to all such representations and would not be allowed to open bids if he fails to reply to such representations.

All GeM Sellers/Service Providers shall ensure full compliance with all applicable labour laws, including the provisions, rules, schemes and guidelines under the four Labour Codes i.e. the Code on Wages, 2019; the Industrial Relations Code, 2020; the Occupational Safety, Health and Working Conditions Code, 2020; and the Code on Social Security, 2020 as and when notified and brought into force by the Government of India.

For all provisions of the Labour Codes that are pending operationalisation through rules, schemes or notifications, the corresponding provisions of the pre-existing labour enactments (such as The Minimum Wages Act, 1948, The Payment of Wages Act, 1936, The Payment of Bonus Act, 1965, The Equal Remuneration Act, 1976, The Payment of Gratuity Act, 1972, etc. and relevant State Rules) shall continue to remain applicable.

The Seller/ Service Providers shall, therefore, be responsible for ensuring compliance under:

- **All notified and enforceable provisions of the new Labour Codes as mentioned hereinabove; and**
- **All operative provisions of the erstwhile Labour Laws until their complete substitution.**

All obligations relating to wages, social security, safety, working conditions, industrial relations etc. and any other statutory requirements shall be strictly met by the Seller/ Service Provider. Any non-compliance shall constitute a breach of the contract and shall entitle the Buyer to take appropriate action in accordance with the contract and applicable law.

[यह बिड सामान्य शर्तों के अंतर्गत भी शासित है /This Bid is also governed by the General Terms and Conditions](#)

जेम की सामान्य शर्तों के खंड 26 के संदर्भ में भारत के साथ भूमि सीमा साझा करने वाले देश के बिडर से खरीद पर प्रतिबंध के संबंध में भारत के साथ भूमि सीमा साझा करने वाले देश का कोई भी बिडर इस निविदा में बिड देने के लिए तभी पात्र होगा जब वह बिड देने वाला सक्षम प्राधिकारी के पास पंजीकृत हो। बिड में भाग लेते समय बिडर को इसका अनुपालन करना होगा और कोई भी गलत घोषणा किए जाने व इसका अनुपालन न करने पर अनुबंध को तत्काल समाप्त करने और कानून के अनुसार आगे की कानूनी कार्रवाई का आधार होगा।/In terms of GeM GTC clause 26 regarding Restrictions on procurement from a bidder of a country which shares a land border with India, any bidder from a country which shares a land border with India will be eligible to bid in this tender only if the bidder is registered with the Competent Authority. While participating in bid, Bidder has to undertake compliance of this and any false declaration and non-compliance of this would be a ground for immediate termination of the contract and further legal action in accordance with the laws.

---धन्यवाद/Thank You---

FORWARDING LETTER & INSTRUCTION TO BIDDERS

OIL INDIA LIMITED (OIL) is a premier National Oil Company engaged in the business of Exploration, Production and Transportation of Crude Oil and Natural gas. A Maharatna Company under the Ministry of Petroleum and Natural gas, Government of India (GOI), with its Headquarters at Duliajan, Assam. Duliajan is connected by Air with nearest Airport at Dibrugarh, 45 km away.

In connection to its operations, OIL invites **DOMESTIC COMPETITIVE BIDS** from competent and experienced bidders through GEM portal for the items mentioned below. You are invited to submit your most competitive bid on or before the scheduled bid closing date and time through GEM portal. For your ready reference, few salient points of the Tender are highlighted below.

TENDER INFORMATION SUMMARY

1A	Bid Security	: Applicable Bid Security if submitted in the form of BG/e-PBG must be valid at least for a period of 6 months from the date of original bid closing date of the tender i.e. valid upto 30.06.2026 NOTE: Original Bank Guarantee will have to be submitted directly to OIL on or before the Bid closing date and time, failing which the bid may be rejected.
1B	Bid Security Declaration	: Not Applicable
2	Performance Guarantee	: Applicable @ 5 % of Order value for PO value more than Rs. 10.00 Lakhs
3	Integrity Pact	: Applicable
4	MSE Purchase Preference	: Applicable
5	PPP-MII Purchase Preference	: Applicable
6	Preference to domestically manufactured Iron and Steel product (DMI&SP Policy)	: Not Applicable
7	Document Verification by independent third party inspection agencies	: Not Applicable (Detailed in clause 47 of under CC: General Notes to Bidders of Annexure – A)
8	Restrictions on procurement from a bidder of a country which shares a land border with India	: Applicable
9	Sustainable Development (SD) and Environment, Social & Governance (ESG) Policy	: Not Applicable
10	OIL's Banning policy	: Applicable
11	Pre - despatch inspection	: Not Applicable

12	Third party inspection (TPI)	:	Applicable – By Supplier for item 2 & 3
13	Installation & Commissioning	:	Not Applicable
14	Training	:	Not Applicable
15	Annual Maintenance Contract	:	Not Applicable
16	OIL's PR No.	:	1428601, 1428286, 1632401, 1428771. FP-07 Quote this reference number for all correspondence with OIL.

LIST OF ANNEXURES/PROFORMAS

ANNEXURES			
Annexure - I	:	Technical Specifications, Scope of Work, Special terms & Conditions etc.	
Annexure - II	:	Price Break up	
Annexure - III	:	Bid Evaluation Criteria / Bid Rejection Criteria (BEC/BRC)	
Annexure - IV	:	Technical & Commercial Checklist	
Annexure - V	:	General Conditions of Contract (GCC) & Special Conditions of Contract (SCC) for procurement of Goods	
Annexure - VI	:	Bid Evaluation Matrix (Technical Specification)	
Annexure - VII	:	Bid Evaluation Matrix (Bid Evaluation Criteria)	
Annexure - VIII	:	Policy for providing preference to Domestically Manufactured Iron & Steel Products (DMI & SP)	
Annexure - IX	:	General Conditions of Contract <i>(For all services to be rendered including AMC)</i>	
PROFORMAS			
Proforma - A	:	Format for undertaking towards compliance of Financial Criteria	
Proforma - B	:	Format for Annual Turn Over and Net Worth Certificate	
Proforma - C	:	Format for Corporate Guarantee towards Financial Standing	
Proforma - D	:	Format for Integrity Pact	
Proforma – E(I), E(II), E(III)	:	Formats for undertaking towards compliance of restriction on procurement from a bidder of a country which shares a land border with India	
Proforma - F	:	Format for Performance Security	
Proforma – G A	:	Format for Bid Security	
Proforma – G B	:	Format for Bid Security Declaration	
Proforma - H	:	Format for undertaking towards submission of authentic information/ documents	
Proforma - I	:	Format for Authorization letter For attending Tender Opening	
Proforma – J	:	Format for Exception / Deviation	
Proforma – K	:	Format for Undertaking For Local Content	
Proforma - L	:	Format for Power of Attorney / Authorization letter (Regarding authority for submission of bid)	
Proforma – M	:	Format for Bidders financial standing	
Proforma – N1	:	Format for declaration that bidder is not under holiday list/delisted/blacklisted/debarred	
Proforma – N2	:	Format for declaration of NCLT / NCLAT /DRT /DRAT/ Court Receivership/ Liquidation	
Proforma – O	:	Format for Inspection Certificate to be issued by Independent Inspection Agencies against Document Verification Clause	
Proforma – P	:	Format for Bank Guarantee linked with Advance Payment	

Proforma -Q	: Format for Insurance surety bond for Bid security and Performance security
Proforma -R	: Format for Sustainable Development (SD) and Environment, Social & Governance (ESG) Policy
Proforma -S	: Format for Document Verification by independent third party inspection agencies

ANNEXURE – I

TECHNICAL SPECIFICATION/SCOPE OF WORK/SPECIAL TERMS & CONDITIONS

Item No	Item Description	Total Qty (In Nos)
1	2.7/8" Mud Motor	2
2	LUBRICATOR ASSEMBLY	5
3	ROD, POLISHED	8
4	4-5/8" OD SH Overshot with accessories	2
5	4-5/8" OD FS Overshot with accessories	4

AA) TECHNICAL SPECIFICATIONS

TECHNICAL EVALUATION MATRIX (TO BE FILLED IN BY BIDDER DULY SIGNED)

Clause Number	DESCRIPTION	TO BE FILLED BY THE BIDDER Relevant Location of their Bid to support the remarks / compliance (Reference of Document name / Serial number / Page number of bid for documentary evidence)
	<p>Item 1: 2.7/8" Mud Motor, Qty-02 Nos.</p> <p>TECHNICAL SPECIFICATION FOR 2.7/8 INCHES OD MUD MOTOR:</p> <p>A) 2.7/8" INCH (73.03 MM) OD DOWN HOLE MUD MOTOR WITH SLICK (STRAIGHT) HOUSING, MEDIUM SPEED HIGH TORQUE POWER SECTION, RUGGED BEARING PACK, SAFETY CATCH FEATURES AND DUMP VALVE ASSEMBLY, DESIGNED FOR HIGH PERFORMANCE, EXTREME DOWNHOLE OPERATIONAL ENVIRONMENTS AND SUITABLE FOR CARRYING OUT SAND CLEANING, CEMENT CLEANING AND MILLING OF BRIDGE PLUG, PACKER, JUNK, ETC., INSIDE 5.1/2 INCHES OD (15 PPF) CASING, WITH ALL ACCESSORIES AS PER THE FOLLOWING SPECIFICATIONS:-</p> <p>Note: Bidder to indicate Make & Model of the offered Mud Motor.</p> <p>B) PHYSICAL SPECIFICATIONS:</p> <p>1) Motor OD: 2 7/8" inch (73.03mm)</p> <p>2) Lobe configuration (within): within 5:6 to 7:8</p>	

<p>3) Number of stages (within): 3.0 to 7.0</p> <p>4) Overall Length (maximum): 20 feet (6.10M)</p> <p>5) Top connection (box): 2 3/8 REG</p> <p>6) Bit box connection: 2 3/8 REG</p> <p>7) Bearing type: Mud lubricated</p> <p>8) Stator Elastomer: High Performance "Hard Rubber"</p> <p>9) Dump valve: Removable Dump valve assembly with 2 3/8 inch API Reg RH (Box-up x Pindown) connection</p> <p>10) Housing: Slick (straight) type housing</p> <p>11) Safety catch: In-built rotor safety catch system to prevent fishing operation on a broken motor</p> <p>B) OPERATIONAL SPECIFICATIONS:</p> <p>1) Indicative Flow rate range: 40 gpm to 170 gpm</p> <p>2) Indicative Operating Bit speed range at full load: 140 rpm to 300 rpm</p> <p>3) Operating Differential pressure at full load (minimum): 700 psi (49 kg/sq cm)</p> <p>4) Operating Torque at full load (minimum): 700 ft-lbs - 750 ft-lbs</p> <p>5) Peak/Stall torque (minimum): 1000 ft-lbs (1340 N-m)</p> <p>6) Maximum Differential pressure at Peak/Stall torque (minimum): 1000 psi (70 kg/sq cm)</p> <p>7) Peak power output (minimum): 50 Hp (37.3 KW)</p> <p>8) Dynamic weight on bit (minimum): 8000 lbs (4 ton)</p> <p>9) Maximum Weight on bit : 15,000 lbs</p> <p>10) Working over-pull (minimum): 13000 lbs (6.5 ton)</p> <p>11) Motor yield (minimum): 175000 lbs (87.5 ton)</p> <p>12) Temperature rating (minimum): 248 deg F / (120 deg C)</p> <p>13) Working fluid:</p> <p>a) Salt solution: Sodium dichromate, catch, common salt, CMC and 6000 ppm salt.</p> <p>b) Drilling fluid: Water base mud and KCL / NaCl mud.</p> <p>D) ACCESSORIES:</p> <p>1) 1 No. of Lifting Sub, compatible with 2-3/8" API Reg. Box Connection with Each Motor</p> <p>.2) Spare Compatible Dump Valve Assembly – 1 No. with Each Motor</p>	
--	--

SPECIAL NOTE TO BIDDERS FOR ITEM No. 1

1. The Bidder should indicate the name of manufacturer, country of origin and port of dispatch of their offered Mud-Motors.
2. The Bidder must provide detailed specifications against all the tender parameters under physical and operational specification including the make and model of the offered Mud-Motor(s) and forward relevant Catalogue, Drawing, Literature and Performance curves (consisting of speed curve, torque curve and power curve with full-load/operating-limit line indicated therein) along with the quotation in support of their offer.
3. The threading and gauging of rotary shouldered connections of the offered Mud-Motors are to be done as per API Spec 7-1 (Latest edition) and Bidder is required to forward a copy of valid API Spec. 7-1 certificate of the manufacturer/threader (depending on who does the threading & gauging) along with the supply in the event of an order. Bidder to confirm the same while quoting.
4. All parts of the Mud-Motor(s) should be suitably marked for identification purpose. Additionally, OIL purchase order number should be die stamped on the body of the Mud-Motors in the event of an order. Bidders shall confirm the same while quoting.
5. The Mud-Motor(s) should be suitably coated with a protective coating both internally and externally to prevent corrosion and rusting during transit. Bidders must confirm the same while quoting.
6. Bidder should forward a list of recommended spares for 02 (two) years operation for the quoted Mud-Motor(s) indicating part numbers, quantity & unit price separately along with the quotation in the commercial bid and categorically confirm the same in the technical bid (price should not be mentioned in the technical bid). However, the cost of these spares will not be considered for bid evaluation purpose. The price should remain valid for at least 02 (two) years.
7. Additionally, the Bidder shall submit an un-priced list of recommended spares for 02 (two) years operation against the quoted Mud-Motor(s), indicating year wise requirement, part numbers and quantity along with the technical bid.
8. All test certificates/ reports (including Dynamometer test reports consisting of speed curve, torque curve and power curve with full-load/operating-limit line indicated therein) of the supplied Mud-Motors should be submitted to OIL along with the supply. Bidder must confirm the same while quoting.
9. The Bidder should confirm to provide along with the supply, 02(two) sets of Operation, service and maintenance manual indicating assembling and disassembling procedures, drawing and spare parts list with part numbers against each size of the Mud Motors.
10. The Mud Motors along with the accessories are to be procured from the same source for compatibility of the items. Bidder shall quote accordingly.
12. Any deviation(s) from the tender specification should be clearly highlighted specifying justification in support of deviation

Item 2: LUBRICATOR ASSEMBLY, Qty- 5 Nos.

1. Lubricator assembly for 0.092" Slickline of 2 7/8" OD x 5000psi WP. The assembly shall be made up of following components:

- A. Mechanical stuffing box
- B. Nipple, 2", Qty - 01 No
- C. Wing Union, FIG 602, 2" with Lip Seal, Qty - 01 No
- D. Riser Pipe, 2 7/8" x 10 ft, Qty - 01 No
- E. Cross Over Nipple, 2 7/8" X 3", Qty - 01 No
- F. Unibolt Coupling, 3" Qty - 01 No
- G. Nipple, 3", Qty - 01 No
- H. Bleed Off Point
- I. Swivel Clamp

The General Arrangement of the Lubricator Assembly should conform to Sketch No: OIL/PSS/P&D/30/B. The features of the components of the Lubricator Assembly are detailed below.

(A) Mechanical Stuffing Box, Qty - 01 No

- a) Wireline size : 0.092" dia
- b) Sheave size : 8" dia
- c) Sheave material : Nylatron
- d) Working Pressure : 5,000 psi
- e) Test Pressure : 7,500 psi
- f) MOC : AISI 4140 / 4130 / Equivalent.
- g) Elastomer : VITON / HNBR / Equivalent.
- h) Service : Sweet
- i) Bottom Connection : 2" API 5L LP treaded box

(B) Nipple, 2", Qty - 01 No

- a) Size : 2"
- b) Length : 6"
- c) Working Pressure : 5,000 psi
- d) Test Pressure: 7,500 psi
- e) MOC : AISI 4140/ 4130/ Equivalent
- f) Top Connection : 2" API 5L LP Threaded Pin
- g) Bottom Connection : 2" API 5L LP Threaded Pin

(C) Wing Union, FIG 602, 2" with Lip Seal, Qty - 01 No

- a) Size : 2"
- b) Working Pressure : 5,000 psi
- c) Test Pressure : 7,500 psi
- d) MOC : AISI 4140/ 4130/ Equivalent
- e) Elastomer : Buna-N
- f) Top Connection : 2" API 5L LP Threaded Box
- g) Bottom Connection : 2" API 5L LP Threaded Box

(D) Riser Pipe, 2 7/8" x 10 ½ ft, Qty - 01 No

- a) Pipe Size : 2 7/8" OD, 2.441" ID, 2.347" Drift dia.
- b) Pipe Length : 10 ½ feet
- c) Working Pressure : 5,000 psi
- d) Test Pressure : 7,500 psi
- e) MOC : AISI 4140/ 4130/ Equivalent

	<p>f) Top Connection : 2" API 5L LP Threaded Pin</p> <p>g) Bottom Connection : 2 7/8" API 5L NU Threaded & coupled / Box</p> <p>h) Lifting Rings : Two Nos of suitable lifting rings should be welded on top and bottom of the riser pipe & in same line, to facilitate hoisting / transporting the lubricator manually by two persons.</p> <p>(E) Cross Over Nipple, 2 7/8" X 3", Qty - 01 No</p> <p>a) Length : 10"</p> <p>b) Working Pressure : 5,000 psi</p> <p>c) Test Pressure : 7,500 psi</p> <p>d) MOC : AISI 4140/ 4130/ Equivalent</p> <p>e) Top Connection : 2 7/8" API 5L NU Threaded Pin</p> <p>f) Bottom Connection : 3" API 5L LP Threaded Pin</p> <p>(F) Unibolt Coupling, 3", Qty - 01 No Complete with suitable Bronze Seal Ring and T-Head Bolt & Nut.</p> <p>a) Size : 3"</p> <p>b) Working Pressure : 5,000 psi</p> <p>d) MOC : Alloy Steel</p> <p>h) Service : Sweet</p> <p>e) Top Connection : 3" API 5L LP Threaded Box</p> <p>f) Bottom Connection : 3" API 5L LP Threaded Box</p> <p>(G) Nipple, 3", Qty - 01 No</p> <p>a) Size : 3"</p> <p>b) length : 6"</p> <p>c) Working Pressure : 5,000 psi</p> <p>d) Test Pressure : 7,500 psi</p> <p>e) MOC : AISI 4140/ 4130/ Equivalent</p> <p>f) Top Connection : 3" API 5L LP Threaded Pin</p> <p>g) Bottom Connection : 3" API 5L LP Threaded Pin</p> <p>h) Thread Protector : Suitable thread protector for bottom connection, for protection of the thread during transportation of the lubricator.</p> <p>(H) Bleed Off Point: One no. 1/2" API 5L LP Threaded high pressure socket should be welded near top end of the Cross Over Nipple "E" for installing needle valve to bleed off the pressure of the lubricator assembly.</p> <p>(I) Swivel Clamp: Upper part of the swivel clamp shall be welded to the Cross Over Nipple "E" and lower part of the swivel clamp shall be welded to the 3" Nipple "G". The swivel clamp shall be designed & installed such that when opened, there is enough clearance to slide up the unibolt coupling ring and the slickline tools and the following features shall be met.</p> <p>a) Bolt & Nut : Swivel clamp shall be complete with bolt & nut along with washers.</p> <p>b) MOC : AISI 4140/4130/ ASTM A36/ ISO 2062 :2011Grade E250A / Equivalent.</p> <p>c) Plate thickness : 15 mm</p> <p>d) Welding : Low-hydrogen electrodes to be used. Suitable preheat temp to be maintained during welding. Slow cooling and stress relieve required</p>	
--	---	--

	<p>2. The following items are be supplied as accessories / spares against each Lubricator Assembly.</p> <p>(A) 2 7/8" Extension Riser Pipe, Qty - 03 Nos a) Pipe Length : 2 feet – 2 Nos 3 feet – 1 No b) Pipe Size : 2 7/8" OD, 2.441" ID, 2.347" Drift dia. c) Working Pressure : 5,000 psi d) Test Pressure: 7,500 psi e) MOC : AISI 4140/ 4130/ Equivalent f) Top Connection : 2 7/8" API 5L LP Threaded Pin g) Bottom Connection : 2 7/8" API 5L LP Threaded & coupled / Box</p> <p>(B) Needle Valve, 1/2" x 5000 WP, Qty - 02 nos a) Size : 1/2" b) Working Pressure : 5,000 psi c) Type : Straight Through d) Connection : 1/2" API 5L LP Threaded Pin</p> <p>(C) Seal Ring for Unibolt Coupling, Qty - 02 Nos a) Size : 3" b) Material : Bronze</p>	
	<p>SPECIAL NOTE TO BIDDERS FOR ITEM No. 2</p> <p>1. Suppliers are to note that the drawing supplied by OIL is purely to guide the suppliers to make the final working drawings by them. Manufacturer's working drawing should be sent to OIL for approval along with Quality Assurance Plan (QAP) prior to the commencement of manufacture of the lubricator. The Bidder shall confirm the same in their technical Bid.</p> <p>2. All welding joints should be 100% radio graphically tested. Radiographic test report should be produced to TPI inspector while inspecting and subsequently to be provided with supply of the materials. The Bidder shall confirm the same in their technical Bid.</p> <p>3. The following documents shall be forwarded with the technical bid: a) Typical General Arrangement Diagram (GAD) of the lubricators showing components. b) Cross sectional dimensional drawings of the components.</p> <p>4. Test Certificates: The successful bidder to provide following certificates along with the supply as per standard of manufacture & QAP. The Bidder shall confirm the same with the technical bid. a) Raw materials: Chemical & mechanical test certificate as per standard specified in technical specification. b) Hydraulic test certificate, radiographic test certificate, certificate of Quality & Standard of welding. c) Inspection Certificate of threads (As per Std: API 5B)</p> <p>5. Painting: External surface shall be cleaned, followed by 2 coats of heat resistant primer followed by high temperature paint.</p>	

	<p>6. Marking: The following shall be suitably marked on the Riser's body</p> <ol style="list-style-type: none"> a) Manufacturer Name b) Pressure Rating. c) Year of Manufacture. d) OIL's Purchase Order No. <p>7. THIRD PARTY INSPECTION (TPI):</p> <ol style="list-style-type: none"> a) Supplier shall arrange and pay for inspection (TPI) of the materials through OIL's approved Third Party Inspection Agency at Bidder's/ Manufacturer's plant/premises as per the broad Scope of Work mentioned the tender. All cost towards the engagement of Third Party Inspection agency shall be borne by supplier. Supplier shall include the cost of Third Party Inspection in the GEM price schedule. b) Third party inspection of items will be carried out by any of the TPI agencies indicated below. <ol style="list-style-type: none"> i) M/s Lloyds. ii) M/s Bureau Veritas iii) M/s RITES iv) M/s I.R.S v) M/s Tuboscope Vetco (To be considered after opening of office in India). vi) M/s DNV-GL <p>The scope of works for the Third-Party Inspection Agency will include but not limited to the following:</p> <ol style="list-style-type: none"> a) Inspection of raw materials. b) Inspection of radiography of welded joints. c) Inspection of threads (Standard API 5B). d) Inspection of bought-out items. e) Inspection of final dimensional and ensure proper workmanship. f) Inspection of Painting. g) To witness hydro test. Pressure recorder should be used for hydro test. The test certificates/reports and recorder charts are to be sent to OIL. h) Verification of certificates for physical and chemical properties of raw materials used. i) Inspection Reports along with copies of the certificates duly endorsed by the TPI must be submitted to OIL. j) The above scope inspection is for general guideline only. If TPI desire to carry out any additional inspection with respect to fabrication of the lubricator assembly, shall be included during appointment of TPIA. <p>NOTE:</p>	
--	---	--

	<p>Bidders should submit their bids explicitly mentioning their detailed comments pointwise, against all the NIT terms and conditions by submitting the filled in and duly signed Annexures I. Any deviation from the tender specification should be clearly mentioned.</p>	
	<p>Item 3: ROD, POLISHED, Qty- 08 Nos.</p> <p>Alloy Steel Polished Rod for Sucker Rod Pump</p> <p>Polished Rod of Alloy Steel (Cr-Mo Alloy Steel AISI 4140) manufactured in accordance with API Spec 11B.</p> <p>Features:</p> <p>Length: 25 ft OD : 1.5" End Connections: 1" SR Pin as per API-11B</p>	
	<p>Special Note to Bidders for Item No. 3</p> <p>1. The bidder should be an Original Equipment Manufacturer (OEM) of the tendered item/equipment or a sole selling agent / authorized distributor / authorized dealer / authorized supply house/ wholly owned subsidiary company of an Original Equipment Manufacturer (OEM) of the tendered item /equipment.</p> <p>Bidders other than OEM must submit valid Authorization Letter with back-up warranty from the OEM, along with the bid. The Authorization letter must be duly sealed & signed by the OEM on their official letter head.</p> <p>The authorization certificate / letter shall be valid for the entire period of execution of the order.</p> <p>2. The original equipment manufacturer (OEM) of tender item /equipment must be having valid API 11 B certificate holding continuously for last 05 years from original bid closing date of this tender. Copies of API 11 B certificates of the OEM shall be submitted accordingly along with the technical bid for verification.</p> <p>3. The bidder shall categorically submit an undertaking along with the bid that the OEM will ensure to keep the API 11 B certificate valid, continuously till completion of supply of the entire purchase order.</p> <p>4. The Packing of Polished Rods Shall be according to Recommendation of API 11B to prevent damage during handling and Transportation. Necessary care to be taken to prevent stresses due to cold bending of Polished Rods during lifting.</p> <p>5. Colour Coding / Marking on the items shall be done as per recommendation of API 11B.</p>	

6. Thread protectors shall be designed & installed to protect the pin or box thread from physical damage during transportation and handling

7. THIRD PARTY INSPECTION (TPI):

Supplier shall arrange for inspection (TPI) of the items as per recommendation of API 11B at supplier's workshop through OIL's nominated Third Party Inspection Agency at Bidder's/ Manufacturer's plant/premises as per the broad Scope of Work mentioned the tender. All cost towards the engagement of Third Party Inspection agency shall be borne by supplier. Supplier shall include the cost of Third Party Inspection in the GEM price schedule.

ii) Third party inspection of items will be carried out by any of the TPI agencies indicated below.

i) M/s Lloyds.

ii) M/s Bureau Veritas

iii) M/s RITES

iv) M/s I.R.S

v) M/s Tuboscope Vetco (To be considered after opening of office in India).

vi) M/s DNV-GL

The scope of works for the Third-Party Inspection Agency will include but not limited to the following:

- a. Supplier shall arrange for inspection (TPI) at Manufacturer's plant/premises as per the approved Drawings & QAP.
- b. All cost towards the engagement of Third-Party Inspection Agency shall be borne by Supplier. **Bidder shall quote/include the cost of Third-Party Inspection in their offer.**
- c. The scope of works for the Third-Party Inspection Agency will include but not limited to the following:
 - a) Inspection of chemical test reports of raw materials.
 - b) Inspection of mechanical properties of finished products.
 - c) Inspection of final dimensions and ensure proper workmanship.
 - d) Inspection of threads.
 - e) Inspection of Painting / Markings.
- d. The above scope inspection is for general guideline only. If TPI desire to carry out any additional inspection, the same shall be included during appointment of TPIA.

Inspection Reports along with copies of the certificates duly endorsed by the TPI must be submitted to OIL.

NOTE:

Bidders should submit their bids explicitly mentioning their detailed comments pointwise, against all the NIT terms and conditions by

	<p>submitting the filled in and duly signed Annexures I. Any deviation from the tender specification should be clearly mentioned.</p> <p>Item 4 : 4-5/8" OD SH Overshot with accessories, Qty-2 Nos.</p> <p>117.475 mm (4.5/8") OD Slim Hole, Right hand, releasing and circulating overshot</p> <p>117.475 mm (4.5/8 inches) OD Slim Hole, Right hand, releasing and circulating overshot as per the following minimum specification:</p> <p>1) 117.475 mm (4.5/8 inches) OD, Slim Hole, Right Hand, releasing and circulating overshot (Bowen series - 150 or equivalent) complete with spiral grapple, grapple control and type `A' packer to catch and pack - off 95.25 mm (3.3/4 inches) OD fish and furnished with 117.475 mm (4.5/8 inches) OD standard lipped guide, lock ring set, top sub type `SS' with 73.025 mm (2.7/8 inches) EUE tubing thread, Right Hand box up connection with pressed steel thread protector.</p> <p>2) ACCESSORIES FOR EACH OF ABOVE ITEM:</p> <ol style="list-style-type: none"> 1. Spiral grapple, size-95.25 mm (3.3/4 inches): 1(one) Number 2. Type `A' packer, size-95.25 mm (3.3/4 inches): 1(one) Number 3. Spiral grapple, size-92.075 mm (3.5/8 inches): 2(two) Numbers 4. Type `A' packer, size-92.075 mm (3.5/8 inches): 2(two) Numbers 5. Spiral grapple, size-88.90 mm (3.1/2 inches): 2(two) Numbers 6. Type `A' packer, size-88.90 mm (3.1/2 inches): 2(two) Numbers 7. Spiral grapple, size-82.55 mm (3.1/4 inches): 1(one) Number 8. Type `A' packer, size-82.55 mm (3.1/4 inches): 1(one) Number 9. Spiral Grapple Control for 4.625 inches OD SH Overshot: 4(Four) Numbers 10. Basket Grapple, size-79.375 mm (3.1/8 inches): 1(one) Number 11. Mill Control Packer (Double pack off) for basket grapple with inner and outer seals, 79.375 mm (3.1/8 inches): 1(one) Number 12. Basket Grapple, size-76.20 mm (3 inches): 1(one) Number 13. Mill Control Packer (Double pack off) for basket grapple with inner and outer seals, size-76.20 mm (3 inches): 1(one) Number 14. Basket Grapple, size-72.025 mm (2.7/8 inches): 2(two) Numbers 15. Mill Control Packer (Double pack off) for basket grapple with inner and outer seals, size-72.025 mm (2.7/8 inches): 2(two) Numbers 16. Basket Grapple, size-60.325 mm (2.3/8 inches): 1(one) Number 17. Mill Control Packer (Double pack off) for basket grapple with inner and outer seals, size-60.325 mm (2.3/8 inches): 1(one) Number 18. Basket Grapple Control for 4.625 inches OD SH Overshot: 4(Four) Numbers 19. Bowl for 117.475 mm (4.5/8 inches) OD SH Overshot: 1(one) Number 20. Top sub, type (SS) with 2.7/8 inches EUE tubing thread, Right Hand, box up top connection (Internal Diameter of Top Sub: 2.3/8 inches): 4 (four) Numbers 21. Standard lipped guide 117.475 mm (4.5/8 inches) OD: 1 (one) Number 22. 190.50 mm (7.1/2 inches) OD oversize lipped Guide compatible with the overshot: 1(one) Number 23. Extension subs, size - 117.475 mm (4.5/8 inches) OD & 24 inches long: 1(one) Number 24. Extension subs, size - 117.475 mm (4.5/8 inches) OD & 36 inches long: 1(one) Number 25. Lock Ring set for 117.475 mm (4.5/8") OD SH Overshot: 1(one) Number 26. Lock Ring spacer for 117.475 mm (4.5/8") OD SH Overshot: 1(one) Number 	
--	--	--

	27. Operation and maintenance manual for Item - 10: 01 (one) set	
	<p>Item 5: 4-5/8" OD FS Overshot with accessories, Qty- 4 Nos.</p> <p>117.475 mm (4.5/8") OD Full strength, Right hand, releasing and circulating overshot</p> <p>117.475 mm (4.5/8 inches) OD Full strength, Right hand, releasing and circulating overshot as per the following minimum specification:</p> <p>1) 117.475 mm (4.5/8 inches) OD, Full strength, Right Hand, releasing and circulating overshot (Bowen series - 150 or equivalent) complete with spiral grapple, grapple control and type `A' packer to catch and pack - off 88.90 mm (3½ inches) OD fish and furnished with 117.475 mm (4.5/8 inches) OD standard lipped guide, lock ring set, short top sub type `SS' with 73.025 mm (2.7/8 inches) API Regular, Right Hand box up connection with pressed steel thread protector.</p> <p>2) ACCESSORIES FOR EACH OF ABOVE ITEM:</p> <ol style="list-style-type: none"> 1. Spiral grapple, size-88.90 mm (3½ inches): 1(one) Number 2. Spiral grapple, size-79.375 mm (3.1/8 inches): 1(one) Number 3. Spiral Grapple Control, size-88.90 mm (3½ inches): 1(one) Number 4. Spiral Grapple Control, size-79.375 mm (3.1/8 inches): 1(one) Number 5. Type `A' packer, size-88.90 mm (3½ inches): 1(one) Number 6. Type `A' packer, size-79.375 mm (3.1/8 inches): 1(one) Number 7. Basket Grapple, size-76.20 mm (3 inches): 1(one) Number 8. Basket Grapple, size-72.025 mm (2.7/8 inches): 1(one) Number 9. Basket Grapple, size-60.325 mm (2.3/8 inches): 1(one) Number 10. Basket Grapple, size-50.80 mm (2 inches): 1(one) Number 11. Basket Grapple Control, size-76.20 mm (3 inches): 1(one) Number 12. Basket Grapple Control, size-72.025 mm (2.7/8 inches): 1(one) Number 13. Basket Grapple Control, size-60.325 mm (2.3/8 inches): 1(one) Number 14. Basket Grapple Control, size-50.80 mm (2 inches): 1(one) Number 15. Mill Control Packer (Double pack off) for basket grapple with inner and outer seals, size-76.20 mm (3 inches): 1(one) Number 16. Mill Control Packer (Double pack off) for basket grapple with inner and outer seals, size-72.025 mm (2.7/8 inches): 1(one) Number 17. Mill Control Packer (Double pack off) for basket grapple with inner and outer seals, size-60.325 mm (2.3/8 inches): 1(one) Number 18. Mill Control Packer (Double pack off) for basket grapple with inner and outer seals, size-48.26 mm (2 inches): 1(one) Number 19. Extension subs, size - 117.475 mm (4.5/8 inches) OD & 24 inches long: 1(one) Number 20. Extension subs, size - 117.475 mm (4.5/8 inches) OD & 36 inches long: 1(one) Number 21. Standard lipped guide 117.475 mm (4.5/8 inches) OD: 1 (one) Number 22. Bowl, size - 117.475 mm (4.5/8 inches): 1(one) Number 23. Top sub, type (SS) with 2.7/8 inches EUE tubing thread (Right Hand) box up top connection: 1(one) Number 24. 142.875 mm (5.5/8 inches) OD oversize lipped Guide compatible with the overshot: 1(one) Number 25. Lock Ring for 117.475 mm (4.5/8") OD 26. Spacer 27. Wall Hook Guide: 01 (one) number 28. Operation and maintenance manual for Item - 20: 2 (two) sets 	

SPECIAL NOTE TO BIDDERS FOR ITEM Nos. 4 & 5

1. The overshot along with all the components should be suitable for fishing operation with all types of drilling and work-over fluids.
2. The bidder should confirm to provide one set of Operation, service & maintenance manual (indicating assembling & disassembling procedures, drawing and spare parts book having illustrated drawings and exploded views of the items with part number) for each of the item along with the supply.
3. The Bidder should furnish a list of recommended spares for two (02) years operation indicating part numbers, quantity and unit price of each and every spares separately along with the quotation in the commercial bid and categorically confirm the same in the technical bid (price should not be mentioned in the technical bid). However the cost of these spares will not be considered for bid evaluation purpose. The price should remain valid for at least two (02) years.
4. All parts should be suitably marked for identification purpose. Bidders shall confirm compliance to the same while quoting.
5. The item should be suitably coated with a protective coating both internally & externally to prevent corrosion and rusting during transit
6. Threading and gauging of the rotary shoulder connections of spears should be as per API Spec.7-1 [latest edition]. Valid API Spec. 7-1 certificate of the Threader having authorization for Threading of Rotary Shoulder Connections should be forwarded along with the bid, failing which the offer will be liable for rejection.
7. In case bidder is not the Original Equipment Manufacturer (OEM), proper authorization certificate (in original) is required with back-up warranty & guarantee from OEM to quote against this tender, failing which offer will be rejected.
8. The bidder must specify the offered item in details & should forward relevant product catalogue of the offered item.
9. The bidder may quote either for any one of the items or for all of the items. However, the quoted item / items must be offered along with its accessories. If any of the items are offered without the accessories then the offer of that particular item will be considered as non-responsive and rejected.
10. Bidder quoted as manufacturer must guarantee uninterrupted supply of spares and availability of service for at least 10 years with effect from delivery of the Item / product for the item / product to be supplied under the Tender / Order, if order is awarded to them by OIL.
11. In case the bidder is an authorized distributor / dealer / supply house of any Original Equipment manufacturer (OEM), then bidder must furnish the following documents:
 - (I) Authorization certificate cum warranty backup from the manufacturer in original on manufacturer's letter head should be submitted along with the offer. This certificate valid at the time of bidding and should remain valid during the entire execution period of the order. The concerned manufacturer should also

	<p>guarantee of supplying the items to the bidder in the event of an order on the bidder.</p> <p>(II) The bidder must also submit undertaking in original from the manufacturer for back up guarantee, after sale services and uninterrupted supply of spares for at least 10 years with effect from delivery of the Item / product for the item / product to be supplied under the Tender / Order, if order is awarded to them by OIL.</p>	
	AC - GENERAL TERMS AND CONDITIONS.	
1.	The items shall be brand new, unused & of prime quality. Also, the party has to confirm to provide warranty that the product supplied will be free from all defects & fault in material, workmanship & manufacturing and shall be in full conformity with ordered specifications. This clause shall be valid for 18 months from date of shipment or 12 months from date of receipt/commissioning. The defective materials, if any, rejected by us shall be replaced by the supplier at their own expense. The bidder must confirm the same while quoting.	
2	Make & Model to be quoted compulsorily for the items. Bidder should forward relevant Catalogue, Drawing, and Literature (in printed form only) indicating the quoted items along with the technical bid.	
3.	The Bidder shall submit their bid in tabular form as per Annexure – I: Technical Specification & Annexure – III: Bid Rejection Criteria above.	
4.	PAYMENT TERMS – 100% of material cost shall be paid within 30 days of issue of CRAC.	
5.	Bidder to sign and submit completely filled up Technical Evaluation Matrix for Bid evaluation criteria and Technical specification.	
6.	Bidder should categorically confirm in the technical bid to deliver the items as per delivery schedule mentioned in the tender.	
7	In case the bidder has satisfactorily executed development order (i.e. including satisfactory inspection and Field Trial Testing) for each of similar tendered item of same or higher capacity in the past in OIL/ONGCL, then the bidder does not have to satisfy past supply experience criteria of BEC in OIL provided the specification of items matches to that of OIL.	
8	<p>Delivery: Materials must be delivered within delivery date mentioned in the tender.</p> <p>Unloading at Oil India Limited, Duliajan, Assam:</p> <p>All the Goods in the GeM shall be offered on Free Delivery at Site basis including unloading. HOWEVER, OIL SHALL PROVIDE CRANE FOR UNLOADING OF ITEMS ONLY. Supplier shall depute adequate crew, who has experience of unloading of items at Destination (Duliajan) with necessary safety gears i.e. helmet, safety boots, hand gloves etc. at unloading point.</p>	

	The safety of the crew deputed by the supplier shall entirely be the responsibility of supplier and therefore they shall take all necessary measures/precautions to ensure that no injuries occur to personnel or property. Supplier must ensure that the crew involved for unloading are properly trained on the procedures and aware of the potential hazards while handling the items.	
9	The bidder should indicate the name of the manufacturer, the country of origin and port of dispatch of the materials.	
10	Any deviation(s) from the tender specification should be clearly highlighted specifying justification in support of deviation.	
11	Any statutory variation (increase/decrease) in the rate of Excise duty/Sales tax/ GST / Customs Duty or any statutory levy and Exchange rate after the closing date of tenders/revised priced bid, as the case may be, but within the contractual delivery/completion period will be to the account of OIL subject to documentary evidence. However, any increase in Excise duty/Sales tax/ GST / Customs Duty or any statutory levy and Exchange rate after the expiry of the scheduled date of delivery shall be to the supplier's account. Any decrease in Excise duty/Sales tax/ GST / Customs Duty or any statutory levy and Exchange rate shall be passed on to OIL.	
12	Order of Precedence- In the event of any conflict between the clauses of documents of the tender, following order of precedence shall apply: 1. BEC / BRC. 2. Technical specifications. 3. Special terms and conditions. 4. General terms and conditions. 5. Special conditions of contract (SCC). 6. GeM General terms and conditions (GCC).	
13	As per MoPNG notification no. FP-20013/2/2017-FP-PNG-Part (4) (E-41432) dated 26.03.2024, Local value addition through services such as transportation, insurance, installation, commissioning, training and after sales services support like AMC/ CMC etc. shall not be considered in local content calculation for the tendered item. Bidders to take note of the same while calculating Local content for the tendered item.	
14	Sustainable Development (SD) and Environment, Social & Governance (ESG) Policy. Consequent to the implementation of Sustainable Development (SD) and Environment, Social & Governance (ESG) Policy in OIL, effective from 28.08.2024. For purchase orders value INR 20 Crores and above the successful bidder shall be required to submit a duly filled ESG Questionnaire in the prescribed format within fifteen (15) calendar days from the date of issue of purchase order. Failure to submit the completed ESG Questionnaire within the stipulated timeline may be treated as non-compliance with contractual obligations and dealt with accordingly. The ESG Questionnaire, along with an Explanatory Note for guidance, is provided as Proforma - R of the tender document.	

Drawing of Item 2 — Lubricator assembly

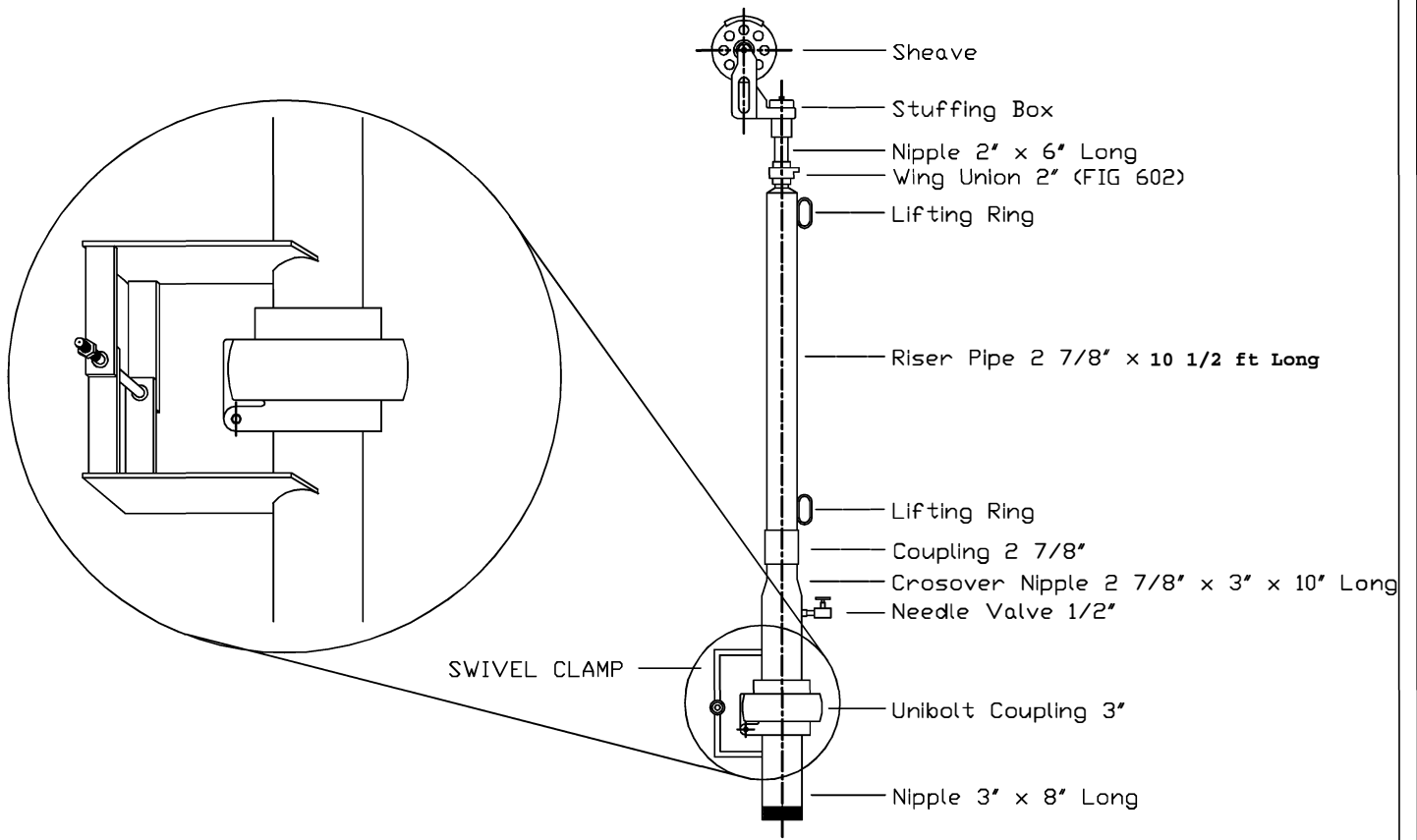

NOTES : NOT TO SCALE	OIL INDIA LIMITED PSS DEPTT. DULIAJAN 786602	WIRELINE LUBRICATOR - GENERAL ARRANGEMENT	DR NO	OIL/PSS/P&D/030/B Pg 1 of 2
----------------------	--	--	----------	-----------------------------

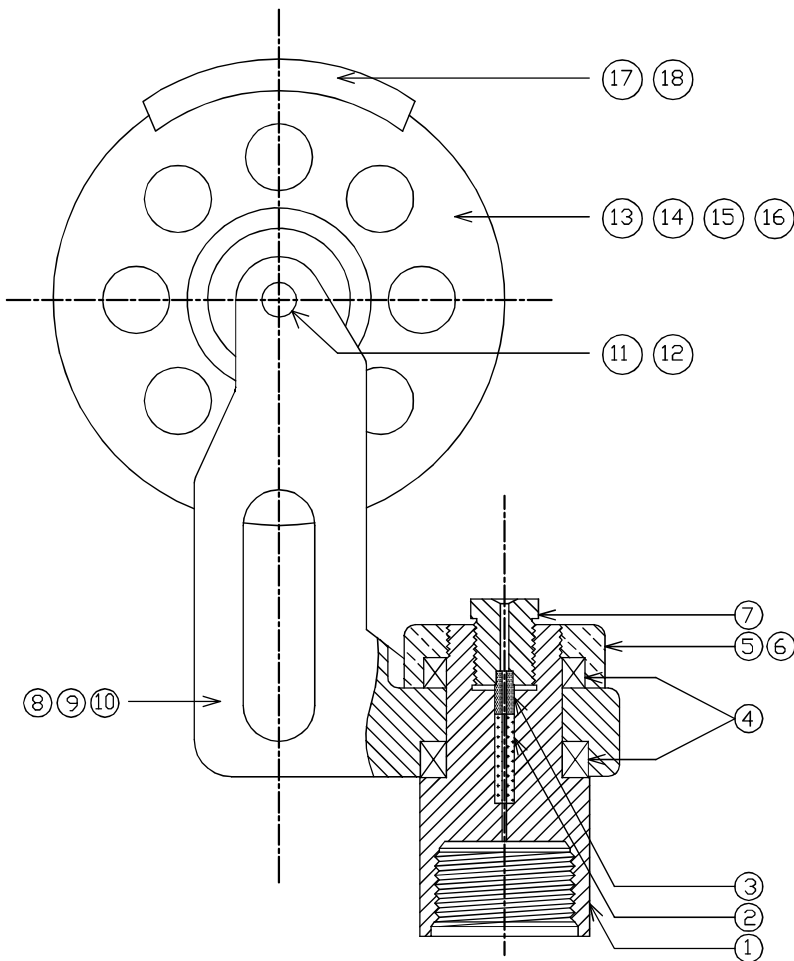

PART LIST

SN	DESCRIPTION	QTY
1	BODY	01 No
2	PACKING - METALLIC	01 No
3	PACKING BUSH - RUBBER	01 No
4	THRUST BALL BEARING	02 Nos
5	BEARING COVER - FOR BODY	01 No
6	SDC SET SCREW	01 No
7	PACKING NUT	01 No
8	SHEAVE BRACKET	01 No
9	SDC. SET SCREW	01 No
10	GREASE NIPPLE	01 No
11	HEX. BOLT	01 No
12	HEX. NYLOCK NUT	01 No
13	SHEAVE	01 No
14	BALL BEARING - FOR SHEAVE	01 No
15	BEARING COVER - FOR SHEAVE	01 No
16	CHEASE HEAD SCREW	02 Nos
17	SHEAVE GUARD	01 No
18	ALLEN HEAD SCREW + WASHER	02 Nos

MATERIAL OF CONSTRUCTION

SN	DESCRIPTION	MATERIAL
1	BODY	AISI 4140/4130
2	PACKING - MATELLIC	BRASS
3	PACKING BUSH - RUBBER	VITON/HBNR/EQVT
8	SHEAVE BRACKET	ALLUMINIUM
13	SHEAVE	ALLUMINIUM

NOTES : NOT TO SCALE

OIL INDIA LIMITED
PSS DEPTT.
DULIAJAN 786602

WIRELINE LUBRICATOR -
STUFFING BOX

DR
NO

OIL/PSS/P&D/030/B Pg 2 of 2

BB: PRE-BID CONFERENCE: Not applicable

ANNEXURE-II

PRICE BREAK UP

A) PRICE BREAK UP OF ITEMS WHOSE COST IS TO BE INCLUDED IN “GEM PRICE SCHEDULE”

Item no.	Item Description	Qty	Unit Price including GST (In Rs)	Applicable GST rate

B) PRICE BREAK UP OF ITEMS WHOSE COST IS NOT TO BE INCLUDED IN “GEM PRICE SCHEDULE”

Item no.	Item Description	Qty	Unit Price including GST (In Rs)	Applicable GST rate

Notes:

- 1. Price break-up to be provided as above, if asked for in the tender.***
- 2. Bidders should fill up, sign and upload this price break up under “Financial documents” of GEM Priced bid only. The price breakup should not be uploaded under GEM Technical bid as it shall lead to rejection of the bid.***

ANNEXURE - III

BID EVALUATION CRITERIA (BEC)

The bids shall in general conform to the specifications and terms and conditions given in the tender. Bids shall be rejected in case the goods offered do not conform to the required minimum/maximum parameters stipulated in the technical specifications and to the respective international / national standards wherever stipulated. Notwithstanding the general conformity of the bids to the stipulated specifications and terms and conditions, the following requirements will have to be particularly met by the bids, without which the same will be considered as non-responsive and be rejected.

Sl. No.	DESCRIPTION	Bidder's Comments (Confirmed/ Submitted/ Deviation etc.)
A.1	BEC- TECHNICAL FOR ITEM No. 1:	
1.0	IN CASE THE BIDDER IS THE MANUFACTURER:	
1.1	<p>The Bidder must have the experience of supplying minimum 50% quantity (to be rounded to next higher whole figure) of each type of tendered items, of same or higher diameter, in the last 05 (five) years preceding the original bid closing date of this tender, to E&P companies/ Drilling Contractors/ Drilling Service providers which are in the business of Oil & Gas.</p> <p>Documentary evidence in respect of the above should be submitted in the form of copies of relevant Purchase Orders along-with copies of any of the following documents in respect of satisfactory execution of each of those purchase orders, such as:</p> <p>I. Signed and sealed Satisfactory supply / completion / installation report (in original on user's letter head) (OR) II. Bill of Lading (OR) III. Consignee receipted delivery receipt/ challan (OR) IV. Central Excise Gate Pass/Tax Invoice issued under relevant rules of Central Excise/Vat. (OR) V. Commercial Invoice/ Payment Invoice</p> <p>Note: The Purchase Order date(s) and Supply Completion date(s) have to be within the last 05(five) years preceding the original bid closing date of this tender.</p>	
1.2	<p>Those Manufacturers who have successfully supplied minimum 50% quantity (to be rounded to next higher whole figure) of each type of tendered items, of same or higher diameter, to OIL INDIA LTD. (OIL) in the last 05 (five) years preceding the original bid closing date of this tender and the performance of which are found to be satisfactory, shall be considered to qualify the experience criteria as stated in the Clause 1.1 above, provided, they indicate in the bid itself, the Purchase Order No(s). & Date(s), Quantity, Details of Mud Motor(s) supplied to OIL in the past.</p>	

	Note: The Purchase Order date need not be within the last 05(five) years, preceding the original bid closing date of this tender. However, the execution of supply should be within the last 05(five) years preceding the original bid closing date of this tender.	
1.3	The Bidder quoted as Manufacturer should confirm that, the threading and gauging of the rotary shouldered connections of the offered Mud Motors will be done as per API Spec.7-1 [latest edition].	
1.4	The Bidder quoted as manufacturer should forward along with the technical bid, a copy of API Spec 7-1 certificate for threading and gauging of rotary shouldered connections, valid as on original bid closing date of this tender, from the concerned party as per below: i. From the Manufacturer, if threading and gauging of the rotary shouldered connections will be carried out by the Manufacturer themselves. OR ii. From the API approved Threader, if threading and gauging of the rotary shouldered connections will be carried out through an API approved Threader.	
1.5	The Bidder quoted as manufacturer, should furnish an undertaking that, the API Spec 7-1 license for threading and gauging of rotary shouldered connections will be kept valid till execution of the purchase order, from the concerned party as per below: i) From the Manufacturer, if threading and gauging of the rotary shouldered connections will be carried out by the Manufacturer themselves. OR iii. From the API approved Threader, if threading and gauging of the rotary shouldered connections will be carried out through an API approved Threader.	
2.0	IN CASE THE BIDDER IS NOT A MANUFACTURER: In case the Bidder is a sole selling agent/distributor/dealer/supply house of any Manufacturer of the offered item(s), then Bidder must furnish the following documents along with the technical bid failing which the bids will be rejected:	
2.1	Authorization certificate from the manufacturer (in original on manufacturer's letter head) should be submitted along with the technical bid. This certificate should be valid at the time of bidding and should remain valid during the entire execution period of the order.	
2.2	Warranty backup from the manufacturer (in original on manufacturer's letter head) against the quality of the tendered item(s) as specified in the tender.	
2.3	Undertaking from the manufacturer (in original on manufacturer's letter head) guaranteeing supply of items to the bidder in the event of an order on the bidder. This certificate should be valid at the time of bidding and should remain valid during the entire execution period of the order.	
2.4	The Bidder is required to submit documentary evidences along with the techno-commercial bid from the concerned Manufacturer, in respect of the Manufacturer's past supply experience as per clause 1.1 or 1.2 above (as applicable), having supplied such items either by the Manufacturer themselves or through their distributor.	
2.5	The Bidder should submit confirmation from the Manufacturer that the threading and gauging of the rotary shouldered connections of the offered Mud Motors will be as per API Spec.7-1 [latest edition].	
2.6	The bidder should forward along with the technical bid, a copy of API Spec 7-1 certificate for threading and gauging of rotary shouldered connections, valid as on original bid closing date of this tender, from the concerned party as per below: i. From the Manufacturer, if threading and gauging of the rotary shouldered connections will be carried out by the Manufacturer themselves. OR ii. From the API approved Threader, if threading and gauging of the rotary shouldered connections will be carried out through an API approved Threader.	

2.7	<p>The Bidder should furnish an undertaking that, the API license for threading and gauging of the rotary shouldered connections will be kept valid till execution of purchase order, from the concerned party as per below:</p> <p>i) From the Manufacturer, if threading and gauging of the rotary shouldered connections will be carried out by the Manufacturer themselves.</p> <p style="text-align: center;">OR</p> <p>ii) From the API approved Threader, if threading and gauging of the rotary shouldered connections will be carried out through an API approved Threader.</p>	
2.8	<p>Additionally, the Bidder should also have the experience of supplying minimum 50% quantity (to be rounded to next higher whole figure) of each type of tendered items, of same or higher diameter, in the last 05(five) years preceding the original bid closing date of this tender, to E&P companies/ Drilling Contractors/ Drilling Service providers which are in the business of Oil & Gas.</p> <p>Documentary evidence in respect of the above should be submitted in the form of copies of relevant Purchase Orders along-with copies of any of the following documents in respect of satisfactory execution of each of those purchase orders, such as:</p> <p>I. Signed and sealed Satisfactory supply / completion / installation report (in original on user's letter head) (OR)</p> <p>II. Bill of Lading (OR)</p> <p>III. Consignee receipted delivery receipt/ challan (OR)</p> <p>IV. Central Excise Gate Pass/Tax Invoice issued under relevant rules of Central Excise/Vat. (OR)</p> <p>V. Commercial Invoice/ Payment Invoice</p> <p>Note: The Purchase Order date(s) and Supply Completion date(s) have to be within the last 05(five) years preceding the original bid closing date of this tender.</p>	
3.0	Additional Documents:	
3.1	<p>In case, for supplementing manufacturer's supply experience criteria (2.A.ii), the manufacturer submits Purchase Order(s) and relevant documents which is through their sole selling agent/distributor/dealer/ supply house, then following additional documents are also to be submitted:</p> <p>a) Copies of signed Purchase Order(s) /Contract agreement(s) between the manufacturer and the sole selling agent/distributor/dealer/supply house and copies of any of the following documents in respect of satisfactory execution of each of those Purchase Order(s)/Contract agreement(s).</p> <p>i) Bill of Lading (OR)</p> <p>ii) Commercial Invoice / Payment of Invoice of the OEM (OR)</p> <p>iii) Central Excise Gate Pass/Tax Invoice issued under relevant rules of Central Excise/Vat/GST.</p>	
3.2	<p>In case, for supplementing the supply experience criteria for both itself and the manufacturer (2.B.V & 2.B.VI), the sole selling agent / distributor / dealer / supply house of the manufacturer submits same set of signed Purchase Order(s) and relevant documents, then following additional documents are also to be submitted:</p> <p>a) Copies of signed Purchase Order(s) /Contract agreement(s) between the manufacturer and the sole selling agent/distributor/dealer/supply house and copies of any of the following documents in respect of satisfactory execution of each of those Purchase Order(s)/Contract agreement(s).</p> <p>i) Bill of Lading (OR)</p> <p>ii) Commercial Invoice / Payment of Invoice of the OEM (OR)</p> <p>iii) Central Excise Gate Pass/Tax Invoice issued under relevant rules of Central Excise/Vat/GST.</p>	

A.1	BEC- TECHNICAL FOR ITEM Nos. 2 & 3:	
	<p>(A) TECHNICAL CRITERIA: Bidder must meet the following criteria failing which the bid shall be rejected.</p> <p>1.0 Qualification Criteria</p> <p>1.1 The bidder should be an Original Equipment manufacturer (OEM) of the tendered item/ equipment or a sole selling agent/ authorized distributor / authorized dealer /authorized supply house/ wholly owned subsidiary company of an Original Equipment Manufacturer (OEM) of the tendered item / equipment.</p> <p>1.2 The original equipment manufacturer (OEM) of the tender item / equipment must be having valid relevant API certificate (IF APPLICABLE) holding continuously for last 05 years from original bid closing date of this tender. Copies of relevant API certificate (IF APPLICABLE) of the OEM shall be submitted accordingly along with the technical bid for verification.</p> <p>1.3 Original Equipment Manufacturers who have successfully supplied the tendered item to Oil India Limited in the past and whose past performance has been satisfactory would be considered as established source of supply and hence need not satisfy Clause 1.2, above. In this regard, it should be mentioned in the technical bid that the OEM has supplied to OIL earlier and the relevant PO number should be provided. Moreover, the OEM should also have a valid relevant API certificate (IF APPLICABLE) at the time of submission of Technical bid and copy of relevant API certificate (IF APPLICABLE) should be submitted along with technical bid.</p> <p>1.4 The bidder shall categorically submit an undertaking in the technical bid that the OEM will ensure to keep the relevant API certificate (IF APPLICABLE), valid continuously till completion of supply of the entire purchase order quantity, and agree that OIL reserves the right to terminate the order forthwith without thereby incurring any liability to the supplier, in case the relevant API certificate (IF APPLICABLE) becomes invalid during the execution of purchase order.</p> <p>1.5 NOTE TO BIDDERS REGARDING RELEVANT API CERTIFICATION / LICENSE VIDE CLAUSE NO 1.2, 1.3 AND 1.4 ABOVE, Relevant API certificate (IF APPLICABLE) is mentioned in the technical specifications</p> <p>1.6 In case the bidder is quoting as agent/ distributor/ dealer/ supply house/wholly owned subsidiary company, the bidder should submit valid authorisation certificate/letter issued by its Original Equipment Manufacturer (OEM), confirming the Bidders' status as their authorized agent/ distributor/ dealer/ supply house/wholly owned subsidiary company (as the case may be) to sell their products with proper warranty and guarantee back up. Such authorisation certificate/letter shall be valid for the entire period of execution of the order.</p> <p>1.7 NOTES TO BIDDER REGARDING AUTHORISATION</p> <p>1.7.1 Authorization letter must be issued on the official letter head only of the OEM clearly mentioning the status of Bidder i.e., whether sole selling agent / authorised distributor / authorised dealer / authorised supply house of Original Equipment Manufacturer (OEM), failing which the bid shall not be considered for evaluation and in that case the offer shall be rejected straightway. Such certificates/ authority letter issued by a party other than the OEM shall not be considered as valid authorization letter and in such as the bid shall be rejected without any further reference.</p>	

1.7.2 Authorization letter issued by the OEM in any other form such as Direct Chanel Partner / Indirect Chanel Partner/ Chanel Partner/ seller/ Reseller/Sub Dealer / Sub Distributor/Sister Concern shall not be considered for bid evaluation and the offer shall be rejected.

1.7.3 In case the bidder is a wholly owned subsidiary company of the parent company (OEM), in addition to the authorization letter including warranty/ guarantee back-up, the bidder shall also upload/ submit the documents such as board resolution / certificate of incorporation / any other legal certificate along with their offer that would establish the relation between the parent company with the subsidiary company without which the bid will not be evaluated and will be rejected straightway.

2.0 Experience Criteria

2.1 IN CASE THE BIDDER IS AN ORIGINAL EQUIPMENT MANUFACTURER (OEM): The bidder must fulfil the following requirements.

2.1.1 The bidder (OEM) should have supply experience of successfully executed at least 50% tendered quantity (rounded off to next higher integer) (of each of tendered item of same or higher capacity and same or higher working pressure and same or higher sizes) or (of similar item), to any E&P companies/
Oil & Gas Companies or service provider to E&P Companies during last 5 (five) years as on original bid closing date of the tender (either by themselves or through their sole selling agent/distributor/dealer/supply house).

2.2 IN CASE THE BIDDER IS A SOLE SELLING AGENT / AUTHORISED DISTRIBUTOR / AUTHORISED DEALER / AUTHORISED SUPPLY HOUSE OF OEM: The bidder must fulfil the following requirements.

2.2.1 The bidder's OEM (the Principal) should have supply experience of successfully executed at least 50% tendered quantity (rounded off to next higher integer) (of each of tendered item of same or higher capacity and same or higher working pressure and same or higher sizes) or (of similar item), to any E&P companies/Oil & Gas Companies or service provider to E&P Companies during last 5 (five) years as on original bid closing date of the tender (either by themselves or through their sole selling agent/ distributor/ dealer / supply house).

2.2.2 Additionally, the bidder himself as sole selling agent/ distributor/ dealer/ supply house should have supply experience of successfully executed at least 50% tendered quantity (rounded off to next higher integer) of each of tendered item of same or higher capacity and same or higher working pressure and same or higher sizes) or (of similar item), to any E&P companies/Oil & Gas Companies or service provider to E&P Companies during last 5 (five) years as on original bid closing date of the tender, either from same OEM (the principal) or from any other OEM.

2.3 NOTES TO BIDDER REGARDING EXPERIENCE CRITERIA VIDE CLAUSE NO 2.1.1, 2.2.1 AND 2.2.2 ABOVE.

2.3.1 Regarding clause no 2.1.1, 2.2.1 and 2.2.2 above,
a)) "Similar item means tendered item.

2.3.2 The bidder shall submit details previous supply of the bidder and the principal, as and where applicable vide para 2.1.1, 2.2.1 and 2.2.2 above, in a tabular format with the following details:

- i) SL NO
- ii) Client/ Customer Name and Address / E-mail address
- iii) Order No / Contract No.
- iv) Date of order
- v) Technical specifications

- vi) Quantity supplied
- vii) Completion date
- viii) Ref no of supporting document (copy to be enclosed)*
- ix) Page no & e tender file name, where the referred supporting document is available

* Supporting documents to be enclosed in support of the supply experience are as follows,

- (a) Copy(ies) of Purchase Order(s) / Contract document(s), and
- (b) Any of the following documents that confirms the successful execution of the order(s)-

- Performance report from the clients,
- Bill of lading,
- Delivery challan / invoice etc.
- Any other documentary evidence that can substantiate the successful execution of each of the Purchase Orders cited above.

2.3.3 For the purpose of above clauses 2.1.1, 2.2.1 & 2.2.2, the dates of Purchase Order(s)/Contract(s) need not be within 5 years preceding the original bid closing date of this tender, but execution of supply should be within 5 years preceding the original bid closing date of this tender.

2.3.4 Satisfactory supply / completion / installation report should be issued on client's letterhead with signature and stamp.

2.3.5 Bidders showing supply experience towards supply to its sister concern/ subsidiaries shall not be considered as experience for the purpose of meeting BRC.

2.3.6 The bidder who fulfils relevant experience criteria as per clause 2.1.1, 2.2.1 & 2.2.2 vide execution of past orders for Oil India Limited, and their performances are found suitable, need not submit all credentials of past supply experience. For consideration of the above, the bidder has to provide a list of OIL's past purchase orders, with quantity supplied & specifications, which have been received at OIL and found suitable. It may be noted that fulfilment of required quantity for experience criteria clause no 2.1.1, 2.2.1 & 2.2.2 is a must, and only quantity received by OIL & found suitable will be considered for the purpose stated above.

2.3.7 Documents in any language other than English should be got translated in English and the copy of the original version English translation should be got verified from any one of the following:

- i) Official of Indian Embassy / High Commission / Consulate General situated in the country where language has been translated.
- ii) Official of Embassy / High Commission / Consulate General of the country where language has been translated, in India.

2.3.8 The service provider to an E&P company shall mean a company, who has procured the item shown in the experience credential submitted and has provided service by utilizing the equipment by himself to an E&P company or has installed & commissioned the item by himself in oilfield of an E&P company.

2.3.9 In case experience credential is submitted for past supply to a service provider to an Exploration & production (E&P) company, a declaration from the service provider is required to be submitted stating the name and address of the E&P company for which the item mentioned in the experience credential has been utilized for providing the service or has been installed & commissioned in oilfield of the E&P Company.

	<p>2.4 E&P company means Exploration & production company who is engaged in exploration & production of hydrocarbon (crude oil &, natural gas).</p> <p>3.0 DELIVERY CRITERIA The bidder should categorically confirm in the technical bid that the tendered items will be supplied within the delivery period as mentioned in the tender, without which the bid will be rejected.</p>	
	<p>A.1 BEC TECHNICAL FOR ITEM 4 & 5:</p> <p>(A) TECHNICAL CRITERIA: Bidder must meet the following criteria failing which the bid shall be rejected.</p> <p>1.0 Qualification Criteria</p> <p>1.1 The bidder should be an Original Equipment manufacturer (OEM) of the tendered item/ equipment or a sole selling agent/ authorized distributor / authorized dealer /authorized supply house/ wholly owned subsidiary company of an Original Equipment Manufacturer (OEM) of the tendered item / equipment.</p> <p>1.2 The original equipment manufacturer (OEM) of the tender item / equipment must be having valid relevant API certificate (IF APPLICABLE) holding continuously for last 05 years from original bid closing date of this tender. Copies of relevant API certificate (IF APPLICABLE) of the OEM shall be submitted accordingly along with the technical bid for verification.</p> <p>1.3 Original Equipment Manufacturers who have successfully supplied the tendered item to Oil India Limited in the past and whose past performance has been satisfactory would be considered as established source of supply and hence need not satisfy Clause 1.2, above. In this regard, it should be mentioned in the technical bid that the OEM has supplied to OIL earlier and the relevant PO number should be provided. Moreover, the OEM should also have a valid relevant API certificate (IF APPLICABLE) at the time of submission of Technical bid and copy of relevant API certificate (IF APPLICABLE) should be submitted along with technical bid.</p> <p>1.4 The bidder shall categorically submit an undertaking in the technical bid that the OEM will ensure to keep the relevant API certificate (IF APPLICABLE), valid continuously till completion of supply of the entire purchase order quantity, and agree that OIL reserves the right to terminate the order forthwith without thereby incurring any liability to the supplier, in case the relevant API certificate (IF APPLICABLE) becomes invalid during the execution of purchase order.</p> <p>1.5 NOTE TO BIDDERS REGARDING RELEVANT API CERTIFICATION / LICENSE VIDE CLAUSE NO 1.2, 1.3 AND 1.4 ABOVE, Relevant API certificate (IF APPLICABLE) is mentioned in the technical specifications</p> <p>1.6 In case the bidder is quoting as agent/ distributor/ dealer/ supply house/wholly owned subsidiary company, the bidder should submit valid authorisation certificate/letter issued by its Original Equipment Manufacturer (OEM), confirming the Bidders' status as their authorized agent/ distributor/ dealer/ supply house/wholly owned subsidiary company (as the case may be) to sell their products with proper warranty and guarantee back up. Such authorisation certificate/letter shall be valid for the entire period of execution of the order.</p> <p>1.7 NOTES TO BIDDER REGARDING AUTHORISATION</p> <p>1.7.1 Authorization letter must be issued on the official letter head only of the OEM clearly mentioning the status of Bidder i.e., whether sole selling agent / authorised distributor / authorised dealer / authorised supply house of Original Equipment Manufacturer (OEM), failing which the bid shall not be considered for evaluation and in that case the offer shall be rejected straightway. Such certificates/ authority letter issued by a party other than the OEM shall not be considered as valid authorization letter and in such as the bid shall be rejected without any further reference.</p>	

1.7.2 Authorization letter issued by the OEM in any other form such as Direct Chanel Partner / Indirect Chanel Partner/ Chanel Partner/ seller/ Reseller/Sub Dealer / Sub Distributor/Sister Concern shall not be considered for bid evaluation and the offer shall be rejected.

1.7.3 In case the bidder is a wholly owned subsidiary company of the parent company (OEM), in addition to the authorization letter including warranty/ guarantee back-up, the bidder shall also upload/ submit the documents such as board resolution / certificate of incorporation / any other legal certificate along with their offer that would establish the relation between the parent company with the subsidiary company without which the bid will not be evaluated and will be rejected straightway.

2.0 Experience Criteria

2.1 IN CASE THE BIDDER IS AN ORIGINAL EQUIPMENT MANUFACTURER (OEM): The bidder must fulfil the following requirements.

2.1.1 The bidder (OEM) should have supply experience of successfully executed at least 50% tendered quantity (rounded off to next higher integer) (of each of tendered item of same or higher capacity and same or higher working pressure and same or higher sizes) or (of similar item), to any E&P companies/Oil & Gas Companies or service provider to E&P Companies during last 5 (five) years as on original bid closing date of the tender (either by themselves or through their sole selling agent/distributor/dealer/supply house).

2.2 IN CASE THE BIDDER IS A SOLE SELLING AGENT / AUTHORISED DISTRIBUTOR / AUTHORISED DEALER / AUTHORISED SUPPLY HOUSE OF OEM: The bidder must fulfil the following requirements.

2.2.1 The bidder's OEM (the Principal) should have supply experience of successfully executed at least 50% tendered quantity (rounded off to next higher integer) (of each of tendered item of same or higher capacity and same or higher working pressure and same or higher sizes) or (of similar item), to any E&P companies/Oil & Gas Companies or service provider to E&P Companies during last 5 (five) years as on original bid closing date of the tender (either by themselves or through their sole selling agent/ distributor/ dealer / supply house).

2.2.2 Additionally, the bidder himself as sole selling agent/ distributor/ dealer/ supply house should have supply experience of successfully executed at least 50% tendered quantity (rounded off to next higher integer) of each of tendered item of same or higher capacity and same or higher working pressure and same or higher sizes) or (of similar item), to any E&P companies/Oil & Gas Companies or service provider to E&P Companies during last 5 (five) years as on original bid closing date of the tender, either from same OEM (the principal) or from any other OEM.

2.3 NOTES TO BIDDER REGARDING EXPERIENCE CRITERIA VIDE CLAUSE NO 2.1.1, 2.2.1 AND 2.2.2 ABOVE.

2.3.1 Regarding clause no 2.1.1, 2.2.1 and 2.2.2 above,
a)) "Similar item means tendered item.

2.3.2 The bidder shall submit details previous supply of the bidder and the principal, as and where applicable vide para 2.1.1, 2.2.1 and 2.2.2 above, in a tabular format with the following details:

- i) SL NO
- ii) Client/ Customer Name and Address / E-mail address
- iii) Order No / Contract No.
- iv) Date of order

- v) Technical specifications
- vi) Quantity supplied
- vii) Completion date
- viii) Ref no of supporting document (copy to be enclosed)*
- ix) Page no & e tender file name, where the referred supporting document is available

* Supporting documents to be enclosed in support of the supply experience are as follows,

- (a) Copy(ies) of Purchase Order(s) / Contract document(s), and
- (b) Any of the following documents that confirms the successful execution of the order(s)-
 - Performance report from the clients,
 - Bill of lading,
 - Delivery challan / invoice etc.
 - Any other documentary evidence that can substantiate the successful execution of each of the Purchase Orders cited above.

2.3.3 For the purpose of above clauses 2.1.1, 2.2.1 & 2.2.2, the dates of Purchase Order(s)/Contract(s) need not be within 5 years preceding the original bid closing date of this tender, but execution of supply should be within 5 years preceding the original bid closing date of this tender.

2.3.4 Satisfactory supply / completion / installation report should be issued on client's letterhead with signature and stamp.

2.3.5 Bidders showing supply experience towards supply to its sister concern/ subsidiaries shall not be considered as experience for the purpose of meeting BRC.

2.3.6 The bidder who fulfils relevant experience criteria as per clause 2.1.1, 2.2.1 & 2.2.2 vide execution of past orders for Oil India Limited, and their performances are found suitable, need not submit all credentials of past supply experience. For consideration of the above, the bidder has to provide a list of OIL's past purchase orders, with quantity supplied & specifications, which have been received at OIL and found suitable. It may be noted that fulfilment of required quantity for experience criteria clause no 2.1.1, 2.2.1 & 2.2.2 is a must, and only quantity received by OIL & found suitable will be considered for the purpose stated above.

2.3.7 Documents in any language other than English should be got translated in English and the copy of the original version English translation should be got verified from any one of the following:

- i) Official of Indian Embassy / High Commission / Consulate General situated in the country where language has been translated.
- ii) Official of Embassy / High Commission / Consulate General of the country where language has been translated, in India.

2.3.8 The service provider to an E&P company shall mean a company, who has procured the item shown in the experience credential submitted and has provided service by utilizing the equipment by himself to an E&P company or has installed & commissioned the item by himself in oilfield of an E&P company.

2.3.9 In case experience credential is submitted for past supply to a service provider to an Exploration & production (E&P) company, a declaration from the service provider is required to be submitted stating the name and address of the E&P company for which the item mentioned in the experience credential has been utilized for providing the service or has been installed & commissioned in oilfield of the E&P Company.

2.4	E&P company means Exploration & production company who is engaged in exploration & production of hydrocarbon (crude oil &, natural gas).	
3.0	DELIVERY CRITERIA The bidder should categorically confirm in the technical bid that the tendered items will be supplied within the delivery period as mentioned in the tender, without which the bid will be rejected.	

A.2 BEC FINANCIAL

- 1.0** The bidder must have annual financial turnover from Operations of minimum **INR 1.68 Crores** in any of the preceding 3 (Three) financial/accounting years reckoned from the original bid closing date of the tender.

[Annual Financial Turnover of the bidder from Operations shall mean - "Aggregate value of the realization of amount made from the sale, supply or distribution of goods or on account of services rendered, or both, by the company (bidder) during a financial year" as per the Companies Act, 2013 Section 2 (91) .]

- 2.0** "Net Worth" of the bidder should be positive for the financial/accounting year just preceding to the original bid closing date of the tender.

[Net worth shall mean: "Share capital + Reserves created out of profits and securities Premium - Aggregate value of accumulated losses (excluding revaluation reserves) - deferred expenditure - Miscellaneous Expenditure to the extent not written off and carried forward Loss - Reserves created out of write back of depreciation and amalgamation"]

- 3.0** Considering the time required for preparation of Financial Statements, if the last date of preceding financial / accounting year falls within the preceding six months reckoned from the original bid closing date and the Financial Statements of the preceding financial / accounting year are not available with the bidder, then the financial turnover of the previous three financial / accounting years excluding the preceding financial / accounting year will be considered. In such cases, the Net worth of the previous financial / accounting year excluding the preceding financial / accounting year will be considered. However, the bidder has to submit an affidavit/undertaking certifying **(PROFORMA - A)** that 'the balance sheet/Financial Statements for the financial year..... (As the case may be) has actually not been audited so far'.

Note:

a) For proof of Annual Turnover & Net worth any one of the following documents must be submitted along with the technical bid:-

- (i) A certificate issued by a practicing Chartered/ Cost Accountant (with Membership Number and Firm Registration Number), certifying the Annual Turnover & Net worth as per format prescribed in (PROFORMA – B).

OR

- (ii) Financial Statements (Audited Balance Sheet & Profit & Loss account **along with all the schedules/notes forming part of the Balance sheet & Profit and Loss Account**) audited by the auditors appointed under the statute like Companies Act etc. wherever applicable. In cases where the bidding/ supporting company (as applicable) are not required to prepare Audited Financial Statements as per the Law of the Land of the country of the bidding/supporting company as applicable, the bidder shall provide documentary evidence for the same along with a certificate from a practicing Chartered Accountant or equivalent to this effect.

The bidder must also submit the financial statement as per the accounting standards of the country of the bidding/supporting company as the case may be, duly certified by the practicing-chartered accountant or equivalent.

b) In case the bidder is a Central Govt. Organization/PSU/State Govt. Organization/Semi-State Govt. Organization or any other Central/State Govt. Undertaking, where the auditor is appointed only after the approval of Comptroller and Auditor General of India and the Central Government, their certificates may be accepted even though FRN is not available. However, bidder to provide documentary evidence for the same.

4.0 In case the Audited Balance Sheet and Profit & Loss Account submitted along with the bid are in currencies other than INR or US\$, the bidder shall have to convert the figures in equivalent INR or US\$ considering the prevailing conversion rate on the date of Balance Sheet and Profit & Loss Account. A CA certificate is to be submitted by the bidder regarding converted figures in equivalent INR or US\$.

5.0 In case the Bidder is subsidiary company (should be a wholly owned subsidiary of the parent/ultimate parent/holding company) who does not meet financial criteria by itself and submits its bid based on the strength of parent/ultimate parent/holding company, then following documents need to be submitted:

- (i) Turnover of the parent/ultimate parent/holding company (supporting company) should be in line with Para **A.2 (1.0)** above.
- (ii) Net Worth of the parent/ultimate parent/holding company (supporting company) should be positive in line with Para **A.2 (2.0)** above
- (iii) Corporate Guarantee (**PROFORMA - C**) on parent/ultimate parent/holding company's (supporting company) letter head signed by an authorized official undertaking that they would financially support their wholly owned subsidiary company for executing the project/job in case the same is awarded to them.
- (iv) A certificate from the Statutory Auditor of the bidding company to establish the relationship and equity percentage holding between bidding company and the supporting company. The certificate should be duly concurred/endorsed by the Company Secretary or one of the Directors of the company concerned.

The above certificate should not be more than 30 days old as on the original bid closing date.

A3. BEC - COMMERCIAL:

1.0 Bids are invited under SINGLE STAGE TWO BID SYSTEM. Bidders should upload Techno-Commercial Bid (Unpriced Bid) and Priced Bid separately at the designated fields assigned in GeM Portal. Please note that no price details should be furnished in the Technical (i.e. Unpriced) bid. The "Unpriced Bid" shall contain all techno-commercial details except the prices/costs. Bidder not complying with above submission procedure will be rejected.

2.0 The prices/rates offered against the tender must remain firm through delivery and not subject to variation on any account. A bid submitted with an adjustable price condition shall be treated as non-responsive and rejected. No discount whatsoever should be quoted separately. Rates/prices quoted must be net of all discounts.

- 3.0 Bids received in physical form shall be rejected (except the documents specifically called for in hard copies, if any). Also, modifications to bids received after the bid closing date & time shall not be entertained.
- 4.0 Bids containing incorrect/ false/misleading statement(s) shall be rejected.
- 5.0 Validity of the bid shall be minimum 90 days from the date of actual Bid Closing Date. Bids with lesser validity shall be straightway rejected.
- 6.0 Successful bidder will be required to furnish Performance Bank Guarantee @ 5 % of the order value after receipt of PO. The Performance Security must be valid for 3(three) months beyond the Warranty period indicated in the Purchase Order/contract agreement.

The Performance Security must be valid for a period as called for in the tender document. Bidder must confirm the same in their Technical Bid. Offers not complying with this clause will be rejected. (Please refer Annexure – III: GENERAL NOTES TO BIDDERS)

- 7.0 Bids must be accompanied by Bid Security for the amount as mentioned in the tender document and shall be in the prescribed format (PROFORMA – G) if submitted in the form of Bank Guarantee (BG). Bid Security may also be paid through online payment mode. Bid Security must be submitted within the scheduled Bid Closing date and time of the Tender. The amount of Bid Security (EMD) must be strictly as specified in the tender document.

Bid Security if submitted in the form of BG/e-PBG must be valid at least for a period of 6 months from the date of original bid closing date of the tender. Bid shall be rejected without further reference, if the Bid Security (EMD) is not received strictly as above, except where exempted. OIL will not assume any responsibility whatsoever for submission of deficient/faulty Bid Security or for delay/non-delivery of the same. (Please refer Annexure – III: GENERAL NOTES TO BIDDERS)

- 8.0 Bid must be uploaded together with the Integrity Pact (If applicable against the tender) and the same must be duly signed digitally. If any bidder refuses to sign Integrity Pact or declined to submit Integrity Pact, their bid shall be rejected straightway. (Please refer Annexure – III: GENERAL NOTES TO BIDDERS)
- 9.0 Bidders shall accept and comply with the following clauses as given in the Bid Document, failing which bid shall be liable for rejection:

- i) Liquidated Damages
- ii) Warranty/Guarantee of material
- iii) Arbitration / Resolution of Dispute
- iv) Force Majeure
- v) Applicable Laws.

- 10.0 A bid shall be rejected straightway if it does not conform to any one of the following clauses:
 - a) Validity of bid shorter than the validity indicated in the Tender.
 - b) In case the party refuses to sign Integrity Pact.

- c) Original Bid Security not received within the stipulated date & time mentioned in the Tender.
- d) Bid Security with (i) validity shorter than the validity indicated in Tender and/or (ii) Bid Security amount lesser than the amount indicated in the Tender.

11.0 **The items of the tender are splittable hence evaluation shall be done item-wise.**

12.0 The bidder shall submit an undertaking/declaration as per Proforma N1 confirming that they have read and understood OIL's Banning Policy and that, neither they nor any of their allied concerns or partners or associates or directors, or proprietors involved in any capacity, are currently on OIL's Holiday/Banning List. Further, the bidder shall confirm that neither they nor any of their aforementioned entities have, during the last three years, been involved in any transgression with any company conforming to the Transparency International (TI) approach or with any Public Sector Enterprise of India that could justify exclusion from the tender process. The bidder shall also disclose details of all such allied entities, if any, as required under the Banning Policy.

~~13.0 Document Verification by independent third party inspection agencies (Applicable for tenders above INR 5.0 Crores only):~~

~~Oil India Limited (OIL) has engaged 17 (Seventeen) Independent Inspection Agencies to verify and certify various documents submitted by the bidders required against BEC/BRC of the tender (Details already provided in Annexure V of Tender, Clause 30.0)~~

~~13.1 Bidders are required to have their documents, as mandated under the Bid Evaluation Criteria (BEC) / Bid Rejection Criteria (BRC) of the tender, verified and certified by any one of the empaneled Independent Third Party Inspection Agencies listed above. The Inspection Certificate, duly issued by the selected agency, must be submitted along with the Technical Bid. All costs related to verification and certification by the Third Party Inspection Agencies shall be borne solely by the respective bidders. Payments in this regard shall be made directly by the bidders to the Inspection Agencies. OIL shall not be held responsible for any payment related dispute between the bidders and the inspection agencies.~~

~~13.2 The verified and certified documents must be submitted along with the Technical Bid. Any bid submitted with un-verified supporting documents shall not be considered. However, in case a bidder submits its bid along with all relevant supporting documents as per BEC/BRC without getting all/some of them verified by the designated Independent Inspection agency, such bid can be provisionally considered, provided it is accompanied by an Undertaking by the Bidder on their official letterhead towards submission of the duly verified and certified copies/ Inspection Certificate within 07 (Seven) days from the actual date of bid opening to be sent to address: **Office of GM MATERIALS, Materials Department, Oil India Limited, Duliajan 786602, Assam, India and copy of the verified documents to email id : tuhin_roy@oilindia.in**. No reminders or clarifications will be issued by the Company in this regard, and failure to submit the verified/ certified documents within the stipulated time shall result in outright rejection of the bid, at the sole risk and responsibility of the bidder. If a bidder does not submit the undertaking towards submission of third party certification within 7 days from date of Bid Closing date, but certified document reaches us within the cut off date of above seven (7) days, then such bids shall be considered.~~

~~13.3 An Undertaking from Independent Inspection Agencies for Document Verification as per (Proforma S) should be submitted alongwith the Technical bid.~~

14.0 Purchase Preference Clause:

Purchase Preference to Micro and Small Enterprises (MSE) falling within the price band of L1+15% and Purchase Preference Policy Linked with Local Content (PP-LC) falling within the price band of L1+20% shall be applicable to this tender.

14.1 Purchase Preference to MSE Bidders:

Purchase Preference to Micro and Small Enterprises is applicable to this tender. Bidders seeking benefits, under Purchase Preference Policy (MSE) shall have to be registered for that item under the NIC group code under Udyam Registration or UAM.

- (i) In case participating MSE Quote price within price band of L1+15%, such MSE shall be considered for award of contract by bringing down their price to L1 price in a situation where L1 price is from someone other than an MSE.
- (ii) In case of more than one such MSE qualifying for 15% purchase preference, the contract shall be awarded to lowest eligible MSE amongst the MSEs qualifying for 15% purchase preference.

Documentation required to be submitted by MSEs: Categorization and various criteria applicable to MSE bidders shall be guided by the Gazette Notification No. **CG-DL-E-26062020-220191** dated **26.06.2020** and Amendment vide Gazette Notification no. **CG-DL-E-16062021-227649** dated **16.06.2021** and **No. CG-DL-E-19012022-232763** dated **19.01.2022** and **CG-DL-E-06052022-235600** dated **06.05.2022** issued by MINISTRY OF MICRO, SMALL AND MEDIUM ENTERPRISES, and any amendment thereof.

The bidder claiming the MSE status (MSE-General, MSE-SC/ST, MSE-Woman) against this tender has to submit Udyam Registration Number with Udyam Registration Certificate along with the technical bid for availing the benefits applicable to MSEs.

Note: In case bidding MSE is owned by Schedule Caste or Schedule Tribe or Woman entrepreneur, valid documentary evidence issued by the agency who has registered the bidder as MSE owned by SC/ST/Woman entrepreneur should also be enclosed.

14.2 Purchase Preference Policy (PPP-MII):

Purchase preference under Public Procurement (Preference to Make in India) Order, 2017-Revision P-45021/2/2017-PP (BE-II)-Part (4) Vol. II dated 19.07.2024 of Department for Promotion of Industry and Internal Trade (DPIIT), Govt. of India and as amended time to time with modifications as notified vide MoPNG Order No. FP-20013/2/2017-FP-PNG-Part (4) (E-41432) dated 26.04.2022 and FP-20013/2/2017-FP-PNG-Part (4) (E-41432) dated 26.03.2024 (including subsequent amendments thereof, if any) shall be applicable for this Tender. Bidders are advised to check the provisions of the said notifications for their eligibility to bid and seek benefits for Purchase preference, accordingly. The margin of purchase preference shall be 20%.

14.3 Concurrent Application of Purchase Preference Policies:

The quantities under this tender are splitable in the ratio of 3:2:2 as mentioned above and Public Procurement Policy for MSE Order 2012 and PP(MII) Order 2017 as per

Order No. F.1/4/2021-PPD dated 18.05.2023 issued by Public Procurement Division, Department of Expenditure, Ministry of Finance, Govt. of India and any subsequent amendment thereto shall be applicable. Bidders are advised to refer to the said Order for further detail. In case of concurrence application of Purchase Preference Policies, the preference order shall be as mentioned below:

Preference Order	Category of Bidder
1st Preference	MSE Class-I Local Supplier
2 nd Preference	MSE but Non- Class-I Local Supplier
3 rd Preference	Non-MSE but Class-I Local Supplier
4 th Preference	Non-MSE Non- Class-I Local Supplier

Note: Further if multiple bidders are falling under a 'category of bidder', the purchase preference for price matching shall be given to MSEs falling within the price band of L1+15%. Purchase preference shall be given in the following order of preference:

1. SC/ST Women-owned MSEs
2. SC/ST owned MSEs
3. Women-owned MSEs
4. Other MSEs

All other guidelines issued in respect of benefits to MSEs shall prevail. Bidder claiming above relaxation/ exemption need to submit necessary documentary proof of their eligibility along with their techno-commercial bid. The certificate must be valid on the bid closing date.

- 15.0 If there is any discrepancy between the unit price and the total price, the unit price will prevail and the total price shall be corrected. Similarly, if there is any discrepancy between words and figure, the amounts in words shall prevail and will be adopted for evaluation.

16.0 Submission of Forged Documents:

Bidders should note that Company (OIL) may verify authenticity of all the documents /certificates / information submitted by the bidder(s) against the tender. In case at any stage of tendering process or Contract execution etc., if it is established that bidder has submitted forged documents / certificates / information towards fulfilment of any of the tender / contract conditions, Company shall immediately reject the bid of such bidder(s) or cancel / terminate the contract besides taking action as per OIL's Banning Policy dated 6th January 2017, available in the OIL's website. Accordingly, service provider/vendor to submit the Undertaking of authenticity of information/documents.

17.0 Land Border Sharing:

Bidders should submit an Undertaking that, their bid is compliant to Order No. F.No. 6/18/2019-PPD dated 23.07.2020 issued by Ministry of Finance, Department of Expenditure, Public Procurement Division, Govt. of India (including subsequent amendments thereto, if any), regarding restrictions on procurement from a bidder of a country which shares land border with India.

- 18.0 Compliance of The Competition Act, 2002:** The bidder shall strictly comply with

the provisions of the Competition Act, 2002, more particularly, Section-3 of the Act. Any violation of the provisions of the Act shall attract penal action under the Act.

Proforma—S

PROFORMA FOR UNDERTAKING FROM THIRD PARTY DOCUMENT
VERIFICATION INSPECTION AGENCY
(To be submitted on official letter head)

TO,

GM MATERIALS
MATERIALS DEPARTMENT
P.O. DULIAJAN, PIN 786602
DIST. DIBRUGARH, ASSAM, INDIA

Sir,

_____ SUB : OIL's tender No.

M/s _____ having registered office at _____ intend to participate in the above referred tender of OIL INDIA LIMITED.

The tender conditions stipulated that the bidder shall submit documents pertaining to Bid Evaluation Criteria / Bid Rejection Criteria (BEC / BRC), duly verified and certified by designated independent Third Party Document Verification Inspection Agency.

In this regard , we hereby certify that copies of documents pertaining to Bid Evaluation Criteria / Bid Rejection Criteria (BEC / BRC), submitted to us by the bidder. M/s _____ have been verified and certified by us with originals and found to be genuine and authentic. We have signed and stamped on the copies of all the verified and certified documents having _____ nos. pages.

Note: In the event of any requirement, OIL reserves the right to ask the inspection agencies to verify the documents with source, if required at no extra cost to OIL.

_____ Thanking you,
_____ Authorised Person's Signature: _____
_____ Name: _____

TECHNICAL & COMMERCIAL CHECKLIST

A. TECHNICAL CKECKLIST FOR ITEM No. 1

Sl. No.	Technical Parameters	Bidder's Response	Bidder's Specification (wherever applicable)
1	Whether the Make & Model of the offered MUD Motor has been indicated?	Yes/ No	
2	Whether the OD of offered MUD MOTOR is 2.7/8 inch (73.03 mm) ?	Yes/ No	
3	Whether the length of the offered MUD MOTOR is within 20 feet (6.10M) ?	Yes/ No	
4	Whether the housing of the offered MUD MOTOR is a SLICK (Straight) housing?	Yes/ No	
5	Whether the offered MUD MOTOR is complete with removable Dump Valve assembly?	Yes/ No	
6	Whether the offered MUD MOTOR is complete with Rotor safety catch system?	Yes/ No	
7	Whether the offered MUD MOTOR is suitable for operation inside 5. inch (127MM) x 15 PPF casing?	Yes/ No	
8	Whether the Bearing package is Mud lubricated?	Yes/ No	
9	Whether the type of Stator Elastomer is High Performance "Hard Rubber"?	Yes/ No	
25	Whether the offered MUD MOTOR is suitable for operation with the drilling and work-over fluids as mentioned in this tender?	Yes/ No	
26	Whether threading and gauging of the rotary shouldered connection of the offered MUD MOTOR will be done as per API Spec.7-1 [latest edition]?	Yes/ No	
27	Whether the top connection of offered MUD MOTOR is 2 3/8 REG inch API Regular RH Box-up?	Yes/ No	
28	Whether the bit box connection of offered MUD MOTOR is 2 3/8 REG inch API Regular RH Box-down?	Yes/ No	
29	Whether the dump valve assembly connections of the offered MUD MOTOR are 2 3/8 REG inch API Regular RH Box-up and Pin-down?	Yes/ No	
30	Whether detailed technical catalogue and literature of the offered MUD MOTOR along with the three performance curves of the offered mud motor(s) consisting of speed curve, torque curve and power curve with full-load/operating-limit line indicated therein, forwarded with the technical bid?	Yes/ No	
31	Whether the offered MUD MOTOR shall be furnished with elevator sub for lifting purpose & suitable for use with square shouldered 2 3/8 inch OD drill pipe elevator?	Yes/ No	
32	Whether the offered MUD MOTOR shall be furnished with spare Dump valve assembly?	Yes/ No	
33	Whether list of recommended spare parts for two (02) years trouble free operation with unit price and part numbers indicating with year wise consumption pattern forwarded separately along with the commercial against the offered MUD MOTOR?	Yes/ No	

34	Whether un-priced list of recommended spare parts for two (02) years trouble free operation with part numbers indicating year wise consumption pattern forwarded along with the technical bid against the offered MUD MOTOR?	Yes/ No	
35	Whether quoted as manufacturer?	Yes/ No	
36	Whether the name of manufacturer, country of origin and port of shipment has been mentioned?	Yes/ No	
37	Whether the “Matrix for Technical Evaluation Sheet” has been duly filled in and signed?	Yes/No	

&&&

B, TECHNICAL CHECKLIST FOR ITEM Nos. 4 & 5

Sl. No	DESCRIPTIONS	REMARKS
1	Whether the item / items would be brand new, unused & of prime quality?	YES / NO
2	Whether the item / items would be free from all defects & fault in material, workmanship & manufacture and shall be in full conformity with ordered specifications?	YES / NO
3	Whether warranty would be for 18 months from date of despatch or 12 months from the date of commissioning whichever is earlier?	YES / NO
4	Whether the defective item / items / parts, if any, rejected by us will be replaced by you free of cost?	YES / NO
5	Whether detailed technical catalogues and drawings indicating exploded view and dimensions with part numbers for the offered item / items are forwarded?	YES / NO
6	Whether list of recommended spare parts for 02 years trouble free operation with unit price and part numbers of each and every item (year wise) are forwarded along with the quotation?	YES / NO
7	Whether you have mentioned the name of manufacturer, country of origin and port of shipment?	YES / NO
8	Whether you have quoted as manufacturer?	YES / NO
9	Whether Operation and maintenance manual for item / items would be provided along with the supply?	YES / NO
10	Whether services manual and part list book with exploded view for the item / items would be provided along with the supply?	YES / NO
11	Whether threading and gauging of the rotary shoulder connections of overshot / overshots would be as per API Spec.7-1 [latest edition]	YES / NO

C. COMMERCIAL CHECKLIST:

Sl. No.	Requirement	Bidder's Response
1	Whether quoted as manufacturer?	
2	Whether quoted as OEM Dealer/Supply House?	
3	If quoted as OEM Dealer/Supply House -	

	a) Whether submitted valid and proper authorization letter from manufacturer confirming that bidder is their authorized Dealer/supply House for the product offered?	
	(b) Whether manufacturer's back-up Warranty/Guarantee certificate submitted?	
4	Whether agreed to the tender warranty clause of the tender?	
5	Whether submitted EMD/Bid Security / Bid Security Declaration as per tender requirement?	
5.1	EMD/Bid Security (Amount & Validity)	
6	EMD/Bid Security exemption certificate with Validity	
7	Whether quoted a firm delivery period as per the tender requirement?	
8	Whether confirmed to submit PBG as asked for in tender?	
9	Whether confirmed Bid Validity as per the tender requirement?	
10	Whether confirmed Payment Terms as per the tender?	
11	Whether quoted as MSE unit? If yes, whether necessary document submitted?	
12	Whether submitted Integrity Pact duly signed and sealed as per PROFORMA - D? (If applicable as per the tender)	
13	<p>Ministry of Finance of Govt. of India, Department of Expenditure, Public procurement Division vide office memorandum F. No. 6/18/2019-PPD dated 23rd July, 2020(order-Public Procurement no.1) has proclaimed the insertion of Rule 144 (xi) in the General Financial Rules (GFRs), 2017 w.e.f. 23rd July, 2020 regarding restrictions on procurement from a bidder of a country which shares a land border with India on the grounds of defence of India on matters directly or indirectly related thereto including national security. Bidders are requested to take note of the office memorandum and submit their offers accordingly, wherever applicable.</p> <p>In this regard, bidders must submit duly sealed & signed undertaking as per format provided vide, PROFORMA - E(I), E(II) & E(III) along with the technical bid. Whether uploaded along with the bid?</p>	
14	Whether indicated the country of origin for the items quoted? Please mention the "Country of origin" under Remarks here.	
15	Whether submitted format of undertaking by bidders towards submission of authentic information/ documents as per PROFORMA - H	
	Whether indicated 'Local Content' required as per PPP-MII Policy?	
16	Local content amount and percentage. Details of locations at which the local value addition is made.	
17	Whether indicated the import content in Price Bid?	
18	Whether all documents have been submitted as required for fulfilling Experience criteria clause of BRC-Technical.	
19	Name and details of the company to whom the bidder has successfully executed orders / contracts for atleast 50% of the tendered quantity as per Experience criteria clause of BRC-Technical.	
20	Whether submitted the profile and other documents of the company for verification (viz. Annual reports, Memorandum of Association, Article of Association etc.)	
21	Name of Manufacturer	
22	Place of Despatch	
23	Name, Address, Phone No & E-mail id of Bidder	
24	Bank details of Bidder	
25	Whether submitted Proforma - J - Format for Exception / Deviation	

26	Whether submitted Proforma – K - Format for Undertaking For Local Content	
27	Whether submitted Proforma – L - Format for Power of Attorney / Authorization letter (Regarding authority for submission of bid)	
28	Whether submitted Proforma – M - Format for Bidders financial standing	
29	Whether submitted Proforma – N1 Format for declaration that bidder is not under holiday list/delisted/blacklisted/debarred Proforma N2 - Format for declaration of NCLT / NCLAT /DRT /DRAT/ Court Receivership/ Liquidation	
30	Whether submitted Proforma – R Format for Sustainable Development (SD) and Environment, Social & Governance (ESG) Policy	
31	Whether submitted declaration for Document Verification by independent third party inspection agencies (PROFORMA – S)	

ANNEXURE – V- General Conditions of Contract (GCC) & Special Conditions of Contract (SCC) for procurement of Goods

GENERAL CONDITIONS OF CONTRACT (GCC) FOR PROCUREMENT OF GOODS

1.0 The bid is governed by GeM General terms & conditions (GeM GTC) prevalent on the bid closing date of tender.

SPECIAL CONDITIONS OF CONTRACT (SCC) FOR PROCUREMENT OF GOODS

The SPECIAL CONDITIONS OF CONTRACT (SCC) shall supersede the GeM General terms & conditions (GeM GTC).

1.0 Bidders shall submit their offer mentioning pointwise compliance/noncompliance to all the terms & conditions, BEC/BRC, Specifications etc. Any deviation(s) from the tender terms & conditions, BEC/BRC, Specifications etc. should be clearly highlighted specifying justification in support of deviation.

2.0 To ascertain the substantial responsiveness of the bid, OIL reserves the right to ask the bidder for clarification in respect of clauses covered under BRC also and such clarifications fulfilling the BRC clauses in toto must be received on or before the deadline given by OIL, failing which the offer will be summarily rejected. However, bidder(s) must note that there should not be any additional financial involvement arising out of such post tender clarifications.

3.0 The Bidder to submit following Technical Evaluation Sheet along with technical bid -

Annexure – VI: Bid Evaluation Matrix (Technical Specification)

Annexure – VII: Bid Evaluation Matrix (Bid Rejection Criteria)

4.0 INTEGRITY PACT

OIL shall be entering into an Integrity Pact, **if applicable** with the bidders as per format enclosed vide **PROFORMA - D** of the tender document. This Integrity Pact proforma has been duly signed digitally by OIL's competent signatory. The proforma has to be returned by the bidder (along with the technical bid) duly signed (digitally) by the same signatory who signed the bid, i.e., who is duly authorized to sign the bid. Uploading the Integrity Pact with digital signature will be construed that all pages of the Integrity Pact have been signed by the bidder's authorized signatory who sign the Bid. If any bidder refuses to sign Integrity Pact or declines to submit Integrity Pact with the offer, their bid shall be rejected straightway.

OIL's Independent External Monitors at present are as under:

SHRI RAM PHAL PAWAR, IPS (Retd.),
Former Director, NCRB, MHA
E-mail: rpawar61@hotmail.com
ramphal.pawar@ips.gov.in

Shri Ajit Mohan Sharan, IAS (Retd.)
Former Secretary, Ministry of Ayush, Govt. of India
E-mail: ams057@gmail.com

Dr. Ved Prakash, ITS (Retd.)
Flat No. 902, Plot No. GH-26,
Rainbow Apartments, Sector-43,
Gurgaon-122009
Mob No.9810546996
E-mail: ved60prakash@gmail.com

- 4.1 In case of a joint venture, all the partners of the joint venture should sign the Integrity Pact.
- 4.2 In the event of any dispute between the management and the contractor relating to those contracts where Integrity Pact is applicable, in case, both the parties are agreeable, they may try to settle dispute through mediation before the panel of IEMs in a time bound manner. If required, the organizations may adopt any mediation rules for this purpose. In case, the dispute remains unresolved even after mediation by the panel of IEMs, the organisation may take further action as per the terms and conditions of the contract.

5.0 MICRO AND SMALL ENTERPRISES (MSE)

Categorisation and various Criteria applicable to MSE bidders shall be guided by the Gazette Notification No. CG-DL-E-26062020-220191 dated 26.06.2020 and Amendment vide Gazette Notification no. CG-DL-E-16062021-227649 dated 16th June, 2021 , CG-DL-E-21032025-261838 elated 21.03.2025 issued by Ministry of Micro, Small and Medium Enterprises.

The bidder claiming as MSE status (MSE-General, MSE-SCIST, MSE -Woman) against this tender has to submit the following documents for availing the benefits applicable to MSEs:

Udyam Registration Number with Udyam Registration Certificate.

Note: *In case bidding MSE is owned by Schedule Caste or Schedule Tribe entrepreneur or Woman Entrepreneur, valid documentary evidence issued by the agency who has registered the bidder as MSE owned by SC/ST entrepreneur/ Woman Entrepreneurs should also be enclosed.*

- 5.1 For availing benefits of Purchase Preference under Public Procurement Policy, the interested MSE Bidders must ensure that they are the manufacturer of tendered item(s) and registered with the appropriate authority for the said item(s). The technical offer of such MSE Bidders must include a valid copy of relevant MSE Certificate issued by appropriate authority specifying the item as per tender. Purchase Preference of 15% (fifteen percent) shall be extended to the eligible MSE Bidder (i.e. Manufacturer of tendered goods for procurement) over non-MSE L1 Bidder and PO shall be awarded for full tender quantity on such MSE bidder, subject to matching their quoted rates/costs with non-MSE L1 Bidder.

6.0 PREFERENCE TO MAKE IN INDIA (MII)

Department for Promotion of Industry and Internal Trade (DPIIT), has issued the revised 'Public Procurement (Preference to Make in India), Order 2017" vide Order no. No. P-45021/2/2017-PP (BE-II) dated 04.06.2020. Bidders are requested to go through the policy and its subsequent amendments, if any, and take note of the same while submitting their offer.

7.0 DOMESTICALLY MANUFACTURED IRON & STEEL PRODUCTS (DMI & SP):

Steel Policy notified vide Notification No. CG-DL-E-01042025-262208 dated 01.04.2025 and as amended from time to time by Ministry of Steel, Government of India is applicable against this tender. The detailed policy may be referred in Ministry's website. Also, refer **ANNEXURE – VIII** to this tender in this regard.

8.0 RESTRICTIONS ON PROCUREMENT FROM A BIDDER OF A COUNTRY SHARING LAND BORDER WITH INDIA:

Ministry of Finance of Govt. of India, Department of Expenditure, Public procurement Division vide office memorandum F. No. 6/18/2019-PPD dated 23rd July, 2020 (order-Public Procurement no.1) has proclaimed the insertion of Rule 144 (xi) in the General Financial Rules (GFRs), 2017 w.e.f. 23rd July, 2020 and amended vide O.M. No. F.7/10/2021-PPD (1) dated 23.02.2023 (order public procurement no. 4) from Procurement Policy Division, Department of Expenditure, Ministry of Finance forwarded by Department of Public Enterprises vide O.M. No. F. No. DPE/7 (4)/2017-Fin dated 24.02.2023 regarding restrictions on procurement from a bidder of a country which shares a land border with India on the grounds of defence of India on matters directly or indirectly related thereto including national security. Bidders are requested to take note of the following clauses and submit their offers accordingly wherever applicable.

- (1) Any bidder from a country which shares a land border with India will be eligible to bid in this tender only if the bidder is registered with the Competent Authority [Registration Committee constituted by the Department for Promotion of Industry and Internal Trade (DPIIT)]. Further, any bidder (including bidder from India) having specified Transfer of Technology (ToT) arrangement with an entity from a country which shares a land border with India, shall also require to be registered with the same competent authority to be eligible to bid in this tender.
- (2) "Bidder" (including the term 'tenderer', 'consultant' or 'service provider' in certain contexts) means any person or firm or company, including any member of a consortium or joint venture (that is an association of several persons, or firms or companies), every artificial juridical person not falling in any of the descriptions of bidders stated hereinbefore, including any agency branch or office controlled by such person, participating in a procurement process.
- (3) "Bidder (or entity) from a country which shares a land border with India" for the purpose of this Order means:
 - a. An entity incorporated, established or registered in such a country; or
 - b. A subsidiary of an entity incorporated, established or registered in such a country; or
 - c. An entity substantially controlled through entities incorporated, established or registered in such a country; or
 - d. An entity whose beneficial owner is situated in such a country; or
 - e. An Indian (or other) agent of such an entity; or
 - f. A natural person who is a citizen of such a country; or
 - g. A consortium or joint venture where any member of the consortium or joint venture falls under any of the above
- (4) The beneficial owner for the purpose of para (3) above will be as under:
 - (i) In case of a company or Limited Liability Partnership, the beneficial owner is the natural person(s), who, whether acting alone or together,

or through one or more juridical person, has a controlling ownership interest or who exercises control through other means.

Explanation:

- a. "Controlling ownership interest" means ownership of or entitlement to more than twenty-five percent of shares or capital or profits of the company.
 - b. "Control" shall include the right to appoint majority of the directors or to control the management or policy decisions including by virtue of their shareholding or management rights or shareholder's agreements or voting agreements.
 - (ii) In case of a partnership firm, the beneficial owner is the natural person(s) who, whether acting alone or together, or through one or more juridical person, has ownership of entitlement to more than fifteen percent of capital or profits of the partnership;
 - (iii) In case of an unincorporated association or body of individuals, the beneficial owner is the natural person(s), who, whether acting alone or together, or through one or more juridical person, has ownership of or entitlement to more than fifteen percent of the property or capital or profits of such association or body of individuals;
 - (iv) Where no natural person is identified under (i) or (ii) or (iii) above, the beneficial owner is the relevant natural person who holds the position of senior managing official;
 - (v) In case of a trust, the identification of beneficial owner(s) shall include identification of the author of the trust, the trustee, the beneficiaries with fifteen percent or more interest in the trust and any other natural person exercising ultimate effective control over the trust through a chain of control or ownership.
- (5) An Agent is a person employed to do any act for another, or to represent another in dealings with third person.
 - (6) The successful bidder shall not be allowed to sub-contract works to any contractor from a country which shares a land border with India unless such contractor is registered with the Competent Authority.
 - (7) **Validity of Registration:** The registration should be valid at the time of submission of bid and at the time of acceptance of bid. If the bidder was validly registered at the time of acceptance/placement of order, registration shall not be a relevant consideration during contract execution.
 - (8) **Undertaking regarding compliance:** The bidders are required to provide undertakings as per **PROFORMA – E(I), PROFORMA – E(II) & PROFORMA – E(III)** along with their bid towards compliance of the above guidelines for participation in this tender. If the undertakings given by a bidder whose bid is accepted is found to be false, this would be a ground for debarment/action as per OIL's Banning Policy and further legal action in accordance with law.

9.0 SETTLEMENT OF DISPUTES AND ARBITRATION:

9.1. ARBITRATION (APPLICABLE FOR SUPPLIER/CONTRACTOR OTHER THAN PSU/GOVT. DEPARTMENTS AND MSMEs):

9.1.1. Except as otherwise provided elsewhere in the purchase order, if any dispute, difference, question or disagreement arises between the parties or their respective representatives or assignees, in connection with construction, meaning, operation, effect, interpretation of the consequent purchase order/contract or breach thereof which parties are unable to settle mutually or through mutually appointed Outside Expert Committee (OEC), the same shall be referred to Arbitration as provided hereunder:

9.1.2. A party wishing to commence arbitration proceeding shall invoke Arbitration Clause by giving 30 days' notice to the other party. The notice invoking arbitration shall specify all the points of dispute with details of the amount claimed to be referred to arbitration at the time of invocation of arbitration and not thereafter. If the claim is in foreign currency, the claimant shall indicate its value in Indian Rupee for the purpose of constitution of the arbitral tribunal.

9.1.3. The number of arbitrators and the appointing authority shall be as under:

Claim Amount (excluding claim for interest and counter claim, if any)	Number of Arbitrator	Appointing Authority
Upto Rs.5.00 Crore	Not Applicable	Not Applicable
Above Rs.5.00 Crore and Upto Rs. 25 Crore	Sole Arbitrator	OIL
Above Rs. 25 Crore	Three Arbitrators	One Arbitrator by each party and the 3 rd Arbitrator, who shall be the Presiding Arbitrator, by the two Arbitrators.

9.1.4. The parties agree that they shall appoint only those persons as arbitrators who accept the conditions of the arbitration clause. No person shall be appointed as Arbitrator or Presiding Arbitrator who does not accept the conditions of the arbitration clause.

9.1.5. If any of the Arbitrators so appointed dies, resigns, becomes incapacitated or withdraws for any reason from the proceedings, it shall be lawful for the concerned party/arbitrators to appoint another person in his place in the same manner as aforesaid. Such person shall proceed with the reference from the stage where his predecessor had left if both parties consent for the same; otherwise, he shall precede de novo.

9.1.6. Parties agree that neither shall be entitled for any pre-reference or pendent-lite interest on its claims. Parties agree that any claim for such interest made by any party shall be void.

9.1.7. If after commencement of the arbitration proceedings, the parties agree to settle the dispute mutually or refer the dispute to conciliation, the arbitrators shall put the proceedings in abeyance until such period as requested by the parties.

- 9.1.8. Each party shall be responsible to decide for the travel and stay etc. of the arbitrator pointed by it. Claimant shall also be responsible for planning for travel/ stay arrangements of the Presiding Arbitrator and the expenses incurred shall be shared equally by the parties.
- 9.1.9. In case of sole arbitrator, OIL shall make all necessary arrangements for his travel, stay and the expenses incurred shall be shared equally by the parties.
- 9.1.10. The Arbitration shall be held at the place from where the contract /purchase order has been awarded. However, parties to the contract / purchase order can agree for Venue of Arbitration, different from the place of arbitration within India for the convenience of all concerned.
- 9.1.11. The fees to arbitrator(s) shall be governed by the Fourth Schedule of the Arbitration and Conciliation Act, 1996. The fees to the arbitrator(s) and secretarial expenses shall be paid in following manner:
- (i) 20% of the fees on submission of Statement of Claim and Counter Claim by the Claimant and Respondent respectively
 - (ii) 20% of the fees on completion of pleadings
 - (iii) 20% of the fees on commencement of the hearing
 - (iv) 40% of the Fees on conclusion of hearing and before passing of final award.

However, subject to agreement by the Parties, the arbitrator(s) may determine a lump sum amount to be paid towards arbitrator's fees and secretarial expenses by the parties on commencement of the proceedings, which is to be adjusted against first instalment of payment, as prescribed in sl.(ii) above.

- 9.1.12. The Arbitrator(s) shall give reasoned and speaking award and it shall be final and binding on the parties.
- 9.1.13. Subject to aforesaid, provisions of the Arbitration and Conciliation Act, 1996 and any statutory modifications or re-enactment thereof shall apply to the arbitration proceedings under this clause.
- 9.1.14. It is agreed and undertaken by the Parties that irrespective of country of origin of the SELLER, the arbitration proceedings shall be governed by the Arbitration and Conciliation Act, 1996 and under no circumstances, the proceedings shall be construed as International Arbitration.

9.2. ARBITRATION (APPLICABLE IN CASE OF PURCHASE ORDER AWARDED ON CPSE AND GOVT. DEPARTMENTS/ORGANIZATIONS):

In the event of any dispute or difference relating to the interpretation and application of the provisions of commercial contract(s) between Central Public Sector Enterprises (CPSEs)/ Port Trusts inter se and also between CPSEs and Government Departments/Organizations (excluding disputes concerning Railways, Income Tax, Customs & Excise Departments), such dispute or difference shall be taken up by either party for resolution through AMRCD as mentioned in DPE OM No. 4(1)/2013-DPE(GM)/FTS-1835 dated 22-05-2018.

The Committee of Secretaries at the First level (tier) shall finalise its decision within 3(three) months after having received the reference/notice in writing regarding the dispute from the concerned aggrieved party.

Any party aggrieved with the decision of the Committee at the First level (tier) may prefer an appeal before the Cabinet Secretary at the Second level (tier) within 15 days from the date of receipt of decision of the Committee at First level, through its administrative Ministry/Department, whose decision will be final and binding on all concerned.

The Arbitration and Conciliation Act 1996 shall not be applicable to the Arbitration under this clause.

- 9.3. **ARBITRATION (APPLICABLE TO MICRO, SMALL AND MEDIUM ENTERPRISE)**
In the event of any dispute or difference relating to, arising from or connected with the Purchase Order, efforts shall be made to resolve the dispute(s) amicably by mutual consultation and in case such dispute(s) cannot be resolved through mutual consultation, then same shall be resolved through the procedure as prescribed in Section-18 of the Micro, Small and Medium Enterprises Development Act, 2006
- 10.0 **RESOLUTION OF DISPUTES THROUGH CONCILIATION BY OUTSIDE EXPERT COMMITTEE (OEC):**
(Not applicable in cases valuing less than Rs 25 lakhs)
- 10.1. If any dispute, difference, question or disagreement arises between the parties hereto or their respective representatives or assignees, in connection with construction, meaning, operation, effect, interpretation of the purchase order/contract or breach thereof which parties are unable to settle mutually, subject to consent of the Seller, the Purchaser at its discretion may first refer to conciliation through Outside Expert Committee (OEC) to be constituted by CMD, OIL as provided hereunder.
- 10.2. The party desirous of resorting to conciliation shall send a notice of 30 (thirty) days to the other party of its intention of referring the dispute for resolution through OEC. The notice invoking conciliation shall specify all the points of disputes with details of the amount claimed to be referred to OEC and the party concerned shall not raise any new issue thereafter.
- 10.3. CMD, OIL shall nominate three outside Experts, one each from Financial/commercial, Technical and Legal fields from the Panel of Outside Experts maintained by OIL who shall together be referred to as OEC (Outside Experts Committee).
- 10.4. Parties shall not claim any interest on claims/counterclaims from the date of notice invoking conciliation till execution of settlement agreement, if so arrived at. In case, parties are unable to reach a settlement, no interest shall be claimed by either party for the period from the date of notice invoking conciliation till the date of OEC recommendations in any further proceeding.
- 10.5. The Proceedings of the OEC shall be broadly governed by Part III of the Arbitration and Conciliation Act, 1996 including any modifications thereof.
- 10.6. The parties shall be represented by their in-house employees/executives. No party shall bring any advocate or outside consultant/advisor/agent. Ex-officers of OIL who have handled the matter in any capacity directly or indirectly shall not be allowed to attend and present the case before OEC on behalf of Contractor. However, ex- employees of parties may represent their respective organizations.

- 10.7. OEC shall hear both the parties and recommend possible terms of settlement between the parties. The recommendations of OEC shall be non-binding and the parties may decide to accept or not to accept the same or may accept part of the recommendation. Parties shall be at liberty to accept the OEC recommendation with any modification they may deem fit.
- 10.8. Where recommendations are acceptable to both the parties, a settlement agreement will be drawn up in terms of the OEC recommendations or with such modifications as may be agreed upon by the parties. The settlement agreement shall be signed by both the parties. This settlement agreement shall have the same legal status and effect as that of an arbitration award on agreed terms on the substance of the dispute rendered by an arbitral tribunal under Section 30 of the Arbitration and Conciliation Act, 1996.
- 10.9. OIL will share all other guidelines regarding reconciliation through OEC with the supplier when it resorts to settlement through OEC. Both parties agree to adhere to these guidelines.
- 10.10. All the expenditure incurred in the OEC proceedings shall be shared by the parties in equal proportion. The parties shall maintain account of expenditure and present to the other for the purpose of sharing on conclusion of the OEC proceedings.

If the parties are not able to resolve the dispute through OEC or do not opt for conciliation through OEC, the party may invoke arbitration clause as provided in the contract / purchase order.

It is expected to conclude a case by OEC within 8-10 weeks. The place of conciliation shall be Guwahati for all purchase orders issued from the Field HQ, Duliajan and Pipeline HQ, Guwahati, whereas, New Delhi shall be the Place of Conciliation for all other Purchase Orders issued by other spheres of OIL.

Solicitation or any attempt to bring influence of any kind on either OEC Members or PURCHASER is completely prohibited in conciliation proceedings and PURCHASER reserves the absolute right to close the conciliation proceedings at its sole discretion if it apprehends any kind of such attempt made by the SELLER or its representatives.

11.0 EXCLUSIONS

Parties agree that following matters shall not be referred to conciliation or arbitration or OEC:

- i) Any claim, difference or dispute relating to, connected with or arising out of OIL's decision to initiate any proceedings for suspension or debarment or banning, or decision to suspend or to ban or to debar business dealings with the Bidder / Seller and/or with any other person involved or connected or dealing with bid / contract / bidder / Supplier.
- ii) Any claim, difference or dispute relating to, connected with or arising out of OIL's decision under the provisions of Integrity Pact executed between OIL and the Bidder / Supplier.
- iii) Any claim, difference or dispute relating to, connected with or arising out of OIL's decision to comply with any order or directive of any statutory or government authority.

12.0 TAX COLLECTIBLE AT SOURCE (TCS):

Tax Collectible at Source (TCS) applicable under the Income-tax Law and charged by the SUPPLIER shall also be payable by OIL along with consideration for procurement of goods/materials/ equipment. If TCS is collected by the SUPPLIER, a TCS certificate in prescribed Form shall be issued by the SUPPLIER to OIL within the statutory time limit.

Payment towards applicable TCS u/s 206C (IH) of Income Tax Act, 1961 will be made to the supplier provided they are claiming it in their invoice and on submission of following undertaking along with the invoice stating that:

- a. TCS is applicable on supply of goods invoiced to OIL as turnover of the supplier in previous year was more than Rs. 10 Cr. And
- b. Total supply of goods to OIL in FY (As applicable) exceeds Rs. 50 Lakh and
- c. TCS as charged in the invoice has already been deposited (duly indicating the details such as challan No. and date) or would be deposited with Exchequer on or before the due date and
- d. TCS certificate as provided in the Income Tax Act will be issued to OIL in time.

However, Performance Security deposit will be released only after the TCS certificate for the amount of tax collected is provided to OIL. Supplier will extend the performance bank guarantee (PBG), wherever required, till the receipt of TCS certificate or else the same will be forfeited to the extent of amount of TCS, if all other conditions of Purchase order are fulfilled.

The above payment condition is applicable only for release of TCS amount charged by supplier u/s 206C (I H) of Income tax Act, 1961.

13.0 CONCESSIONAL GST

Bidders are requested to quote the actual rate of applicable GST.

~~The items covered in this Tender shall be used by Oil India Limited in the Petroleum Exploration License (PEL) and Mining Lease (ML) areas and hence concessional **GST @18%** will be applicable as per Govt. Policy in vogue.~~

~~**Note:** Successful bidder shall arrange to provide all necessary documents (invoice etc.) to OIL for applying Essentiality Certificate on receipt of request from OIL or at least **30 days** prior to their readiness for despatch, whichever is earlier. Further, successful bidder shall affect dispatch only on receipt of relevant certificates/shipment clearance from OIL, failing which all related liabilities shall be to supplier's account.~~

14.0 APPLICABILITY OF BANNING POLICY OF OIL INDIA LIMITED:

OIL's Banning Policy, 2023 will be applicable against the tender (and order in case of award) to deal with any agency (bidder/contractor/supplier/vendor/service provider) who commits deception, default, fraud or indulged in other misconduct of whatsoever nature in the tendering process and/or order execution processes.

The bidders who are on Holiday/Banning/Suspension list of OIL on due date of submission of bid/ during the process of evaluation of the bids, the offers of such bidders shall not be considered for bid opening/evaluation/award. If the

bidding documents were issued inadvertently/downloaded from website, the offers submitted by such bidders shall also not be considered for bid opening/evaluation/ Award of Work.

- 14.1 The bidder shall fill up and submit proforma of declaration of Blacklisting / Holiday Listing/ NCLT / NCLAT /DRT /DRAT/ COURT RECEIVERSHIP/ LIQUIDATION (as per Proforma – N) along with the technical bid).

15.0 PERFORMANCE SECURITY

Successful bidder will be required to furnish a Performance Bank Guarantee @5% of the order value with validity as mentioned in the tender document. The Performance Security shall be in the form of, Insurance Surety Bonds, account payee Bank Draft/Cashier’s cheque/Banker’s cheque/NEFT/RTGS/ Electronic fund transfer to designated account of OIL or Fixed Deposit Receipt (FDR) (account OIL INDIA LIMITED) or Bank Guarantee (including e-Bank Guarantee) or irrevocable Letter of Credit (LC). The Performance Security must be submitted exactly as per **PROFORMA – F**. Bidder must confirm the same in their Technical Bid.

The Bank Guarantee issued by the bank must be routed through SFMS platform as per the following details:

- (i) MT 760/MT 760 COV for issuance of bank guarantee.
- (ii) MT 760/MT 767 COV for amendment of bank guarantee.

[Order Number should reflect in the SFMS text under MT 760/MT 760 COV]

The above message/intimation shall be sent through SFMS by the BG issuing Bank branch to ICICI Bank, Duliajan Branch, IFSC Code- ICIC0000213, Branch Address.: ICICI Bank Ltd, Kunja Bhavan, Daily Bazaar, Duliajan, Dibrugarh, Assam - 786602. The Bank details are as under:

Bank Details of Beneficiary	
Bank Name	ICICI BANK LTD.
Branch Name	DULIAJAN
Branch Address	KUNJA BHAVAN, DAILY BAZAAR, DULIAJAN, DIBRUGARH, ASSAM - 786602
IFSC Code	ICIC0000213
Unique identifier code (Field 7037)	OIL503988890
Company name	Oil India Limited

The vendor shall submit to OIL the copy of the SFMS message as sent by the issuing bank branch along with the original bank guarantee.

- 15.1 Performance Security shall be issued from any scheduled Indian Bank or any branch of an International Bank situated in India and registered with the Reserve Bank of India as scheduled foreign Bank in case of domestic suppliers.
- 15.2 Bank Guarantees issued by a Bank in India should be on non-judicial Stamp Paper/Frinking receipt of requisite value, as per Indian Stamp Act, purchased in the name of the Banker or the Seller.
- 15.3 Bank Guarantee with condition other than those mentioned in OIL’s prescribed format shall not be accepted.

- 15.4 The Bank Guarantee issued by a Bank amongst others shall contain the complete address of the Bank including Phone Nos., Fax Nos., E-mail address, Code Nos. of the authorized signatory with full name and designation and Branch Code.
- 15.5 The Performance Security shall be payable to Purchaser as compensation for any breach or loss resulting from Supplier's failure to fulfil its obligations under the Purchase Order/Contract. In the event of such default on the part of Seller, the Performance Security shall be encashed unconditionally, and the proceeds thereof shall be forfeited without any further reference to the Seller. In such an eventuality, the Seller shall be liable to face penal actions including debarment as per OIL's Banning Policy, 2023.
- 15.6 The Performance Security shall be discharged by Purchaser not later than 30 days following its expiry after completion of obligations under the order/contract. In the event of any extension to the contractual validity or delay in supply/ execution or extension of Warranty Period of the Purchase Order/Contract, validity of the Performance Security shall be extended by the Seller/Contractor by the equivalent period.
- 15.7 The Performance Security shall not accrue any interest during its period of validity or extended validity. OIL shall not be liable to pay any bank charges, commission or interest on the amount of Performance Security.
- 15.8 Failure of the successful Bidder to comply with the requirements of above clauses shall constitute sufficient grounds for annulment of the award and forfeiture of their Bid Security or Performance Security. The defaulting party shall also be debarred from business as per OIL's Banning Policy, 2023.
- 15.9 In case, the Performance Security in the form of a Bank Guarantee is found to be not genuine or issued by a fake banker or issued under the fake signatures, the Purchase Order placed on the bidder shall be treated as cancelled forthwith and the bidder shall be banned from participating in future tenders in accordance with the provisions of Company's Banning Policy, 2023. Further, the Bid Security submitted by such bidder shall be invoked without any further reference, besides other penal action, as the Company may think appropriate.
- 15.10 In case Annual Maintenance Contract (AMC) is required and OIL intends to enter into a separate contract with the successful bidder for AMC, the Successful bidder must undertake to submit separate Performance Security against the AMC at the applicable rate & validity to be stipulated in the contract. (5% of annualized contract value valid for three months beyond entire execution period).
- 15.11 INSTRUCTIONS FOR FURNISHING "PERFORMANCE SECURITY DEPOSIT" BY "INSURANCE SURETY BOND"
- a) The Insurance Surety Bond shall be from an Insurer as per guidelines issued by Insurance Regulatory and Development Authority of India (IRDAI).
- b) The Company shall be the Creditor, the Contractor shall be the Principal debtor and the Insurance company/Insurer shall be the Surety in respect of the Insurance Surety Bond to be issued by the Insurer.
- c) The Insurance Surety Bond should be on Non-Judicial stamp paper/e-stamp paper of appropriate value as per Stamp Act prevailing in the state(s) where the

Insurance Surety Bond is submitted or is to be acted upon or the rate prevailing in State where the Insurance Surety Bond is executed, whichever is higher. The Stamp Paper/e-stamp paper shall be purchased in the name of Contractor /Insurer issuing the Insurance Surety Bond.

d) The expiry date and values should be arrived at in accordance with instructions provided in the "Forwarding Letter" of the Tender.

e) The Insurance Surety Bond by Contractors will be given from Insurer as specified in the Tender.

f) A letter from the issuing insurer of the requisite Insurance Surety Bond confirming that the said Insurance Surety Bond / all future communication relating to the Insurance Surety Bond shall be forwarded to the Purchaser at its address as mentioned at "ITB".

g) Contractor must indicate the full postal address of the Insurer along with the Insurer 's E-mail / Phone from where the Insurance Surety Bond has been issued.

h) Contractor must indicate Name, Address, Contact number and official Email ID of the Controlling Office of the Surety Issuing Branch or any web portal link, from whom /where the Surety Bond can be got confirmed by the Company.

16.0 BID SECURITY:

If Bid Security /Earnest Money Deposit (EMD) is applicable. Bids must be accompanied by Bid Security for the amount as mentioned in the tender *or an equivalent amount in freely convertible currency and shall be in the form of Insurance Surety Bonds/DD/FDR (account OIL INDIA LIMITED)/NEFT/RTGS/Electronic fund transfer to designated account of OIL/online payment through OIL's e-portal/Bank Guarantee (BG) (including e-Bank Guarantee) in OIL's prescribed format (PROFORMA - GA) or as an irrevocable Letter of Credit (L/C) from any of the following Banks (Refer GeM GTC for details).*

In case of the Bid Security is submitted in the form of Bank Guarantee, scanned copy of Bank Guarantee shall be uploaded by the bidder in the online bid and **Original Bank Guarantee will have to be submitted directly to OIL on or before the Bid closing date and time, failing which the bid may be treated as incomplete and may lead to rejection of the bid by OIL without making any reference to the bidder.**

The Original Bid Security shall be submitted manually in sealed envelope **superscribed** with tender no., tendered item detail and due date to: **GM-MATERIALS, MATERIALS DEPARTMENT, KIND ATTENTION - TUHIN ROY, Dy GENERAL MANAGER, OIL INDIA LIMITED, DULIAJAN- 786602, ASSAM.**

In case of Online payment of Bid Security, bidder shall provide the Online transaction details in their online bid as proof of submission of Bid Security to OIL. The online payment of Bid Security amount should be received in OIL's bank account on or before the Bid closing date and time failing which the offer will be rejected outright without any further reference.

OIL's Bank account Details for Online submission of Bid Security	
Name	Oil India Limited
Bank	State Bank of India
Branch	Duliajan
Account Number	10494832599
Account Type	Current
IFSC Code	SBIN0002053

- 16.1 Bid Security shall be issued from any scheduled Indian Bank or any branch of an International Bank situated in India and registered with the Reserve Bank of India as scheduled foreign Bank in case of domestic suppliers.
- 16.2 Bank Guarantee issued by a scheduled Bank in India at the request of some other non-scheduled Bank in India shall not be accepted.
- 16.3 Bank Guarantees issued by a Bank in India should be on non-judicial Stamp Paper/Franching receipt of requisite value, as per Indian Stamp Act, purchased in the name of the Banker or the Seller.
- 16.4 Bank Guarantee with condition other than those mentioned in OIL's prescribed format/GeM Bank Guarantee format shall not be accepted.
- 16.5 The Bank Guarantee issued by a Bank amongst others shall contain the complete address of the Bank including Phone Nos., Fax Nos., E-mail address, Code Nos. of the authorized signatory with full name and designation and Branch Code.
- 16.6 The bidders will extend the validity of the Bid Security, if and whenever specifically advised by OIL, at the bidder's cost.
- 16.7 The Bid Security shall not accrue any interest during its period of validity or extended validity. OIL shall not be liable to pay any bank charges, commission or interest on the amount of Bid Security.
- 16.8 In case, the Bid Security in the form of a Bank Guarantee is found to be not genuine or issued by a fake banker or issued under the fake signatures, the bid submitted by the concerned bidder shall be rejected and the bidder shall be banned from participating in future tenders in accordance with the provisions of OIL's Banning Policy. Further, the Bid Security submitted by such bidder shall be invoked without any further reference, besides other penal action, as OIL may think appropriate.
- 16.9 In case of Bank Guarantee, the Bank Guarantee issuing bank branch must ensure the following:

The Bank Guarantee issued by the bank must be routed through SFMS platform as per the following details:

- (i) MT 760/MT 760 COV for issuance of bank guarantee.
- (ii) MT 760/MT 767 COV for amendment of bank guarantee.

[Tender Number should reflect in the SFMS text under MT 760/MT 760 COV]

The above message/intimation shall be sent through SFMS by the BG issuing Bank branch to ICICI Bank, Duliajan Branch, IFSC Code- ICIC0000213, Branch Address: ICICI Bank Ltd, Kunja Bhavan, Daily Bazaar, Duliajan, Dibrugarh, Assam – 786602. The Bank details are as under:

Bank Details of Beneficiary	
Bank Name	ICICI BANK LTD.
Branch Name	DULIAJAN
Branch Address	KUNJA BHAVAN, DAILY BAZAAR, DULIAJAN, DIBRUGARH, ASSAM – 786602
IFSC Code	ICIC0000213
Unique identifier code (Field 7037)	OIL503988890
Company name	Oil India Limited

The bidder shall submit to OIL the copy of the SFMS message as sent by the issuing bank branch along with the original bank guarantee.

16.10 The Bid Security of the unsuccessful bidders will be returned after finalization of tender whereas the Bid Security of the successful bidder will be discharged on such bidder's furnishing the Performance Security to OIL against the Purchase Order secured by the bidder within the stipulated time frame. The successful bidder will, however, extend validity of the Bid Security till such time the Performance Security is furnished.

16.11 For timely return of Bid Security, bidders shall submit following details alongwith their technical bid.

- For Bank Guarantee((BG): Name, Email id, Phone number and Address where the Bid Security is to be returned by Courier.
- Online payment: Name, Email id, Phone number and Bank details (Bank Name, Branch Name, Branch Address, IFSC Code, Unique identifier code, Company name) where the Bid Security amount shall be returned by Online transfer.

In case of non-submission of above details, return of Bid Security may be delayed.

16.12 If Bid Security /Earnest Money Deposit (EMD) is not applicable. Instead of EMD /Bid Security, all the bidders shall be required to sign a "Bid Security Declaration" accepting that if they withdraw or modify their Bids during the period of validity, or if they are awarded the contract and they fail to sign the contract, or to submit a performance security before the deadline defined in the NIT/ Purchase order, they shall be suspended for the period of 2 (two) years. This suspension of two years shall be automatic without conducting any enquiry. Bidders shall submit "Bid Securing Declaration" as per enclosed PROFORMA - GB along with their Technical bids.

16.13 INSTRUCTIONS FOR FURNISHING "BID SECURITY DEPOSIT" BY "INSURANCE SURETY BOND"

- a) The Insurance Surety Bond shall be from an Insurer as per guidelines issued by Insurance Regulatory and Development Authority of India (IRDAI).

- b) The Company shall be the Creditor, the Bidder shall be the Principal debtor and the Insurance company/Insurer shall be the Surety in respect of the Insurance Surety Bond to be issued by the Insurer.
- c) The Insurance Surety Bond should be on Non-Judicial stamp paper/e-stamp paper of appropriate value as per Stamp Act prevailing in the state(s) where the Insurance Surety Bond is submitted or is to be acted upon or the rate prevailing in State where the Insurance Surety Bond is executed, whichever is higher. The Stamp Paper/e-stamp paper shall be purchased in the name of Bidder/Insurer issuing the Insurance Surety Bond.
- d) The expiry date and values should be arrived at in accordance with instructions provided in the "Forwarding Letter" of the Tender.
- e) The Insurance Surety Bond by bidders will be given from Insurer as specified in the Tender.
- f) A letter from the issuing insurer of the requisite Insurance Surety Bond confirming that the said Insurance Surety Bond / all future communication relating to the Insurance Surety Bond shall be forwarded to the Purchaser at its address as mentioned at "ITB".
- g) Bidder must indicate the full postal address of the Insurer along with the Insurer 's E-mail / Phone from where the Insurance Surety Bond has been issued.
- h) Bidder must indicate Name, Address, Contact number and official Email ID of the Controlling Office of the Surety Issuing Branch or any web portal link, from whom /where the Surety Bond can be got confirmed by the Company.

16.14 Submission of Bid Security and Performance Security in the form of Electronic Bank Guarantee (e-BG)

Oil India Ltd. has now adopted Electronic Bank Guarantee (e-BG) for Bid Security and Performance Security in addition to the existing provisions. Electronic Bank Guarantee (e-BG) is a digitally signed BG issued by banks which is transmitted directly from banks to beneficiaries in electronic form through a platform provided by National E-Governance Services Limited (NeSL).

Submission of Bid Security/Performance Security, as applicable, in the form of Electronic bank Guarantee (e-BG) is also acceptable:

Sl. No.	Bank Name	Sl. No.	Bank Name
1	AU Small Finance Bank	18	Indian Bank
2	Axis bank	19	Indian Overseas Bank
3	Bank of Baroda	20	IndusInd Bank
4	Bank of India	21	Karnataka Bank
5	Bank of Maharashtra	22	Karur Vysya Bank
6	Canara Bank	23	Kotak Mahindra Bank
7	Central Bank of India	24	Punjab and Sind bank
8	City Union Bank	25	Punjab National Bank

9	DBS Bank	26	RBL Bank
10	DCB Bank	27	Standard Chartered
11	Dhanlaxmi Bank	28	State Bank of India
12	Federal bank	29	South Indian Bank
13	HDFC Bank	30	Tamilnad Mercantile Bank Ltd
14	HSBC Bank	31	UCO Bank
15	ICICI Bank	32	Union Bank of India
16	IDBI Bank	33	Yes Bank
17	IDFC First Bank		

Beneficiary details for issue of e-BG are:

Sl. No.	Particulars	Details
1	Name	Oil India Limited
2	PAN	AAACO2352C
3	Date of Incorporation	18-02-1959
4	Email ID	
5	Mobile No.	
6	Local Address	
7	Registered Address	Duliajan, Dibrugarh, Assam-786602

17 FINANCING OF TRADE RECEIVABLES OF MICRO AND SMALL ENTERPRISES (MSEs) THROUGH TRADE RECEIVABLES DISCOUNTING SYSTEM (TREDS) PLATFORM.

Based on the initiatives of Government of India to help MSE vendors get immediate access to liquid fund based on Buyers credit rating by discounting, OIL has registered itself on TReDS platform with M/s RXIL , M/s A TREDS Ltd. (Invoice Mart), M/s Mynd Solutions Private Limited, M/s C2FO Factoring Solutions Private Limited, M/s. KredX Platform Private Limited. The list of approved/authorized entities is as under:

Sl. No	Name of the Approved/ Authorised Entity	TReDS Payment System Approved/ Authorised
1	M/s Receivables Exchange of India Limited (RXIL)	RXIL
2	M/s A TREDS Ltd	INVOICE MART
3	M/s Mynd Solutions Private Limited,	Mlxchange
4	M/s C2FO Factoring Solutions Private Limited,	C2treds
5	M/s. KredX Platform Private Limited	DTX

MSE vendors can avail this benefit by registering themselves with any of the exchanges providing e-discounting/electronic factoring services on TReDS platform and following the procedures defined therein, provided OIL is also participating in such TReDS Platform as a Buyer.

- i) MSE Vendor should be aware that all costs relating to availing the facility of discounting on TReDS platform including but not limited to Registration charges, Transaction charges for financing, Discounting Charges, Interest on financing, or any other charges known by any name shall be borne by MSE Vendor.
- ii) MSE Vendor hereby agrees to indemnify, hold harmless and keep OIL and its affiliates, Directors, officers, representatives, agents and employees indemnified, from any and all damages, losses, claims and liabilities (including legal costs) which may arise from Sellers submission, posting or display, participation, in any manner, on the TReDS Platform or from the use of Services or from the Buyer's breach of any of the terms and conditions of the Usage Terms or of this Agreement and any Applicable Law on a full indemnity basis.
- iii) OIL shall not be liable for any special, indirect, punitive, incidental, or consequential damages or any damages whatsoever (including but not limited to damages for loss of profits or savings, business interruption, loss of information), whether in contract, tort, equity or otherwise or any other damages resulting from using TReDS platform for discounting their (MSE Vendor's) invoices.

Note:

- (i) Buyer means OIL who has placed Purchase Order/ Contract on a MSE Vendor (Seller).
- (ii) Seller means a MSE vendor, who has been awarded Purchase Order/ Contract by OIL (Buyer).

18 UNLOADING FOR BULKY/HEAVY ITEMS:

All the Goods in the GeM shall be offered on Free Delivery at Site basis including unloading. **HOWEVER, OIL SHALL PROVIDE CRANE FOR UNLOADING OF BULKY/HEAVY ITEMS ONLY.** Supplier shall depute adequate crew, who has experience of unloading of such items at Destination (Duliajan) with necessary safety gears i.e. helmet, safety boots, hand gloves etc. at unloading point.

The safety of the crew deputed by the supplier shall entirely be the responsibility of supplier and therefore they shall take all necessary measures/precautions to ensure that no injuries occur to personnel or property. Supplier must ensure that the crew involved for unloading are properly trained on the procedures and aware of the potential hazards while handling the items.

18.14 OIL reserves the right to divert any truck / trailer originally booked for a particular destination to nearby areas within a distance of 50 km from Duliajan.

19 UNLOADING OF TUBULARS:

All the Goods in the GeM shall be offered on Free Delivery at Site basis including unloading. **HOWEVER, OIL SHALL PROVIDE CRANE FOR UNLOADING OF TUBULARS ONLY.** Supplier shall depute adequate crew, who has experience of unloading of tubulars, at Destination (Duliajan) with necessary safety gears i.e. helmet, safety boots, hand gloves etc. at unloading point. **THE ONLY RESPONSIBILITY OF THE CREW TO BE DEPUTED BY THE SUPPLIER IS TO FASTEN/FIX CRANE'S HOOK SLING TO BUNDLES ON THE LOADED VEHICLE.** Once the hook sling is securely fastened complying to the safety instructions, OIL's Crane shall lift and unload tubulars from the vehicle. Following points are to be noted and complied in this connection:

- (a) Supplier to ensure that height of the loaded tubular is below the cabin height of the vehicle for safe off-loading.
- (b) Supplier to ensure that tubular bundles are securely fastened by very strong material to withstand the rigors of road transportation and capable of lifting by Crane. In the case tubular bundles are found loosened and/or tubulars found completely resting on the side support/bales of vehicle in way that it may free fall upon unshackling, OIL will not unload such vehicle due to safety reasons.

The safety of the crew deputed by the supplier shall entirely be the responsibility of supplier and therefore they shall take all necessary measures/precautions to ensure that no injuries occur to personnel or property. Supplier must ensure that the crew involved for unloading are properly trained on the procedures and aware of the potential hazards while handling tubulars.

19.14 OIL reserves the right to divert any truck / trailer originally booked for a particular destination to nearby areas within a distance of 50 km from Duliajan.

20 UNLOADING OF CONSIGNMENT RECEIVED THROUGH RAIL:

Unloading of consignment from Railway Wagons at Destination (**Duliajan**) shall be completely in OIL's scope.

21 QUANTITY TOLERANCE FOR TUBULARS:

Bidders should note that, in the event of order, quantity tolerance of +0%/-2% of order quantity will be applicable.

22 SET-OFF:

Any sum of money due and payable to the Seller (including Security Deposit refundable to them) under any purchase order may be appropriated by Oil India Limited and set-off against any claim of Oil India Limited (or such other person or persons contracting through Oil India Limited) for payment of a sum of money arising out of any other purchase order made by the Seller with Oil India Limited (or such other person or persons contracting through Oil India Limited).

23 FURNISHING FRAUDULENT INFORMATION/ DOCUMENT:

If it is found that a Bidder has furnished fraudulent document/information, the Bid Security/ Performance Security shall be forfeited and necessary action as per OIL's Banning Policy, 2023 shall be taken, besides the legal action. In this regard, bidders are requested to submit an Undertaking as per **PROFORMA - H** along with their offer failing which their offer shall be liable for rejection.

24 GENERAL CONDITIONS OF CONTRACT FOR SERVICES (ANNEXURE - IX)

General Conditions of Contract FOR SERVICES (GCC - SERVICES) shall be applicable for all services to be rendered including AMC (as and when entered into).

25 MODIFICATION/AMENDMENT OF TENDER DOCUMENT: At any time prior to the deadline for submission of bids, the Company may, for any reason, whether at its own initiative or in response to a clarification requested by a prospective Bidder, modify the tender Documents through issuance of Corrigendum(s)/Addendum(s). Bidders are expected to take the Corrigendum(s)/ Addendum(s) into account in preparation and submission of their bid. No separate intimation for Corrigendum(s)/Addendum(s) published by OIL shall be sent to the Bidders.

26 THIRD PARTY INSPECTION (TPI) (if to be arranged by OIL).

- a) OIL shall arrange for inspection (TPI) of the materials through OIL's nominated Third Party Inspection Agency at Bidder's/Manufacturer's plant/premises as per the broad Scope of Work mentioned the tender. All cost towards the engagement of Third Party Inspection Agency shall be borne by OIL. **BIDDER SHALL NOT QUOTE/INCLUDE THE COST OF THIRD PARTY INSPECTION IN THEIR OFFER.** However, Bidder shall extend all necessary facility to the satisfaction of Third Party Inspection Agency for smooth conduct of the inspection.
- b) Bidder shall clearly indicate in the technical bid the place/plant where Third Party Inspection of the materials shall be conducted, in the event of an order.
- c) Supplier shall convey to OIL the production schedule within 02(two) weeks from the date of Letter of Award (LOA)/Purchase order so that OIL can deploy the TPI agency to carry out inspection at bidder's/manufacturer's premises accordingly. Additionally, Supplier shall send a notice in writing/e-mail to the OIL at least 15 days in advance specifying the exact schedule and place of inspection (TPI) as per the Purchase Order and OIL upon receipt of such notice shall notify to the supplier the date and time when the materials would be inspected by OIL nominated TPI Agency. **Manufacturer QAP for Third Party Inspection must be submitted by the bidder after placement of order.**
- d) The supplier shall provide, without any extra charge to OIL, all materials, tools, labour and assistance of every kind which the OIL nominated TPI Agency may demand for any test or examination required at supplier's premises. The supplier shall also provide and deliver sample from the material under inspection, free of charge, at any such place other than their premises as the TPI Agency may specify for acceptance tests for which the supplier does not have the facilities for such tests at their premises. In the event of testing outside owing to lack of test facility at supplier's premises, the supplier shall bear cost of such test, if any.
- e) The supplier shall not be entitled to object on any ground whatsoever to the method of testing adopted by the OIL nominated TPI Agency.

- f) Unless otherwise provided for in the Purchase Order, the quantity of materials expended in test will be borne by supplier.
- g) The decision of the Third Party Inspection Agency nominated by OIL regarding acceptance/rejection of material shall be final and binding on the supplier.
- h) Upon successful completion of the TPI and acceptance of the TPI reports by OIL, Bidder/Supplier shall be intimated by OIL for dispatch of the materials. The materials should be despatched only after receipt of dispatch clearance from OIL.
- i) Acceptance of the TPI reports and receipt of dispatch intimation from OIL do not absolve the bidder from any warranty obligations or waive the bidder from OIL's right for rejection of the materials after receipt at site.
- j) Notwithstanding clauses contained herein above, in the event the materials under inspection fails to conform to purchase order specification and are rejected by OIL nominated Third Party Inspection agency, OIL may recover all cost incurred for re-inspection of the materials from the supplier.

24.1 THIRD PARTY INSPECTION (TPI) (if to be arranged by Supplier).

Supplier shall arrange for inspection (TPI) of the materials through OIL's empaneled Third Party Inspection Agency at Bidder's/Manufacturer's plant/premises as per the broad Scope of Work mentioned the tender. All cost towards the engagement of Third Party Inspection Agency shall be borne by Supplier. At present, there are six OIL's empaneled Third Party Inspection Agency as under:

- (i)M/s.Lloyds
- (ii)M/s.BureauVeritas
- (iii)M/s.RITES
- (iv)M/s IR CLASS System and Solutions Private Limited
- (v)M/s.Tuboscope Vetco
- (vi)M/s. DNV MES India Private Limited

27 DOCUMENTATION (FOR DOMESTIC/INDIGENOUS SUPPLIERS):

27.14 Preparation and submission of proper documents by Seller is one of the very important requirements. The Seller must strictly follow the instructions.

27.15 Seller shall ensure that all the documents have clear reference of OIL's Purchase Order number.

27.16 Seller shall forward the documents, as mentioned below, by courier service immediately after the dispatch is made:

(I) **WHERE PAYMENT AGAINST DIRECT SUBMISSION OF DESPATCH DOCUMENTS TO COMPANY:**

A)	General Manager (A/P), Finance & Accounts Department	i) Bill in original + one copy. ii) Copy of the C-Note/RR.
----	--	---

	Oil India Limited, Duliajan, PIN - 786602	<ul style="list-style-type: none"> iii) Copy of Mill Inspection Certificate, if any. iv) Copy of Third-Party Inspection Certificate, if any. v) Copy of Delivery Challan. vi) Copy of TPI Declaration vii) Copy of Tax Invoice. viii) Copy of packing list. ix) Documentary evidence of payment of Customs Duty, if any.
B)	DGM - Materials (Receiving), Materials Department Oil India Limited, Duliajan, PIN - 786602	<ul style="list-style-type: none"> i) Clear Consignee copy of RR/C-Note - Original + 1 copy. ii) Copy of Tax Invoice. iii) Delivery Challan (Original). iv) Packing list (Original). v) Mill inspection certificate, if any (Original). vi) Copy of Third-Party Inspection certificate, if any. vii) Copy of TPI Declaration viii) Warranty Certificate (Original)
C)	Chief Manager Materials (FP) Materials Department Oil India Limited, Duliajan, PIN - 786602	One set consisting copies of all the documents as mentioned in (B) above.

Note: *Where payment term is after receipt and acceptance of materials, the complete set of documents meant for General Manager (A/P) as indicated in (A) above should be submitted to Dy. General Manager Materials (Receiving).*

27.0 FORCE MAJEURE:

- 27.1. In the event of either party being rendered unable by Force Majeure to perform any obligations required to be performed by them under the purchase order the relative obligations of the party affected by such force majeure shall upon notification to the other party be suspended for the period during which force majeure event lasts. The cost and loss sustained by the either party shall be borne by the respective parties.
- 27.2. The term force majeure as employed herein shall mean Acts of God such as earthquake, hurricane, typhoon, flood, volcanic activity etc.; war (declared /undeclared); riot, revolts, rebellion, terrorism, sabotage by persons other than the SELLER's Personnel; fires, explosions, ionizing radiation or contamination by radio-activity or noxious gas, if not caused by SELLER's fault; declared epidemic/pandemic or disaster; acts and regulations of respective Govt. of the two parties, namely the PURCHASER and the SELLER and civil commotions, lockout not attributable to the SELLER.
- 27.3. Upon occurrence of such cause(s) and upon its termination, the party alleging that it has been rendered unable as aforesaid thereby, shall notify the other party by a registered letter duly certified by the statutory authorities immediately but not later than 7(seven) days of the alleged beginning and

ending thereof giving full particulars and satisfactory evidence in support of its claim.

27.4. Time for performance of the relative obligations suspended by the force majeure shall then be extended by the period for which such cause lasts. The extension of time shall be the sole remedy of the Seller for any delay under this clause and the Seller shall not be entitled in addition to or in lieu of such extension to claim any damages or compensation on any account whatsoever whether under the law governing contracts or any other law in force, and the Seller hereby waives and disclaims any and all contrary rights.

27.5. If the force majeure conditions persist for a period exceeding two (2) months, the Purchaser reserves the right to cancel the purchase order in full or in part.

28.0 SIGNING OF BIDS:

Bids are to be submitted online in GeM portal. The bid including all uploaded documents shall be signed by duly authorized representative of the bidder holding a Power of Attorney to bind the Bidder to the contract. The letter of authorisation (as per Proforma-L) shall be indicated by written Power of Attorney accompanying the Bid.

29.0 BIDDERS FINANCIAL STANDING:

The bidder should not be under liquidation, court receivership or similar proceedings, should not be bankrupt. Bidder to upload undertaking (as per Proforma-M) to this effect with bid.

30.0 CERTIFICATION OF DOCUMENTS BY INDEPENDENT THIRD-PARTY INSPECTION AGENCIES (TPIA):

30.1 Oil India Limited (OIL) has engaged the following 17 (Seventeen) Independent Inspection Agencies for a period of 04 (Four) years up to 06.06.2028 to verify and certify various documents submitted by the bidders required against BEC/BRC of the tender:

Sl. No.	Name of Independent Inspection Agency	Contact E-mail ID
i.	M/s. Alfred H Knight India Private Limited	a. rkjain@ahkgroup.com; b. pradeep.mathur@ahkgroup.com ; c. info@ ahkgroup.com
ii.	M/s. TUV India Private Limited	a. noida@tuv-nord.com b. mumbai@tuv-nord.com c. salim@tuv-nord.com
iii.	M/s Conformity India International Private Limited	a. mktg@ciindia.in
iv.	M/s Ravi Energetic Private Limited	a. baroda@ravienergetic.com b. tpia@ravienergetic.com

v.	M/s SGS India Private Limited	a. dhaval.vora@sgs.com b. sgs.india@sgs.com
vi.	M/s Assure Quality Management Certification Services Private Limited	a. aqmcs@aqmcs.com
vii.	M/s. IRCLASS Systems and Solutions Private Limited	a. industrial_services@irclass.org b. Bhavesh.satam@irclass.org
viii.	M/s. TÜV Rheinland (India) Pvt. Ltd.	a. Shailesh.deotale@ind.tuv.com b. Kaushal.gohil@ind.tuv.com c. info@ind.tuv.com d. ravi.kumar@ind.tuv.com
ix.	M/s Gulf Lloyds (India) Ltd.	a. contact@gulflloyds.com b. inspection@gulflloyds.com
x.	M/s Baltic Testing India Pvt. Ltd.	a. office@balticcontrolindia.com
xi.	M/s Sanmarg Engineering Validation & Assessment	a. Amitra@sanmargeva.com
xii.	M/s Meenar Global Consultants LLP	a. sales@mgellp.in
xiii.	M/s Rites Limited	a. nrinspn@rites.com b. info@rites.com c. sbu.ninsp@rites.com
xiv.	M/s Bureau Veritas (India) Private Limited	a. bvindia.corporate@bureauveritas.com
xv.	M/s TUV SUD South Asia Private Limited	a. Hemant.chavan@tuvsud.com b. Jayashree.rane@tuvsud.com
xvi.	M/s Adornment Engineers India Private Limited	a. jks@adornmentengineers.com
xvii.	M/s TCRC Inspections Pvt. Ltd.	a. admin@tereinspections.com b. ashismallick@teregroup.com c. tenders@teregroup.com

30.2 Bidders are required to have their documents, as mandated under the Bid Evaluation Criteria (BEC) / Bid Rejection Criteria (BRC) of the tender, verified and certified by any one of the empanelled Independent Third-Party Inspection Agencies listed above. The Inspection Certificate, duly issued by the selected agency, must be submitted along with the Technical Bid. All costs related to verification and certification by the Third-Party Inspection Agencies shall be borne solely by the respective bidders. Payments in this regard shall be made directly by the bidders to the Inspection Agencies. OIL shall not be held responsible for any payment-related dispute between the bidders and the inspection agencies.

30.3 The verified and certified documents must be submitted along with the Technical Bid. Any bid submitted with un-verified supporting documents shall

not be considered. However, in case a bidder submits its bid along with all relevant supporting documents as per BEC/BRC without getting all/some of them verified by the designated Independent Inspection agency, such bid can be provisionally considered, provided it is accompanied by an **Undertaking by the Bidder on their official letterhead towards submission of the duly verified and certified copies/ Inspection Certificate within 07 (Seven) days from the actual date of bid opening to be sent to address Office of GM-MATERIALS, Materials Department, Oil India Limited, Duliajan - 786602, Assam, India and copy of the verified documents to email id : tuhin_roy@oilindia.in**. No reminders or clarifications will be issued by the Company in this regard, and failure to submit the verified/ certified documents within the stipulated time shall result in outright rejection of the bid, at the sole risk and responsibility of the bidder. If a bidder does not submit the undertaking towards submission of third party certification within 7 days from date of Bid Closing date, but certified document reaches us within the cut-off date of above seven (7) days, then such bids shall be considered.

30.4 The methodology of verification/certification of documents followed by the agencies is broadly as under, but not limited to:

- (a) It is the sole responsibility of the bidders intending to participate in the tender to thoroughly understand the requirements of the tender, particularly the documents required under BEC/BRC. The bidders must present all relevant documents to any of the empanelled third-party certifying agencies for verification/certification. Neither OIL nor the Inspection Agencies shall be responsible for the selection or appropriateness of the documents submitted for verification. It is entirely the bidder's responsibility to ensure that the appropriate documents are verified/certified in support of BEC/BRC compliance.
- (b) The concerned Independent Third-Party Inspection Agencies shall depute their qualified/competent inspector to the Bidder's premises to check the original documents and certify the copies which the bidder shall submit along with their bids. OIL will reserve the right to ask the inspection agencies to verify the documents with source, if required at no extra cost to OIL. Verification/Certification of documents by OIL's empanelled third-party inspection agencies shall not automatically make the bidder techno-commercially-acceptable or eligible for award of contract.
- (c) Verification/Certification of documents are normally categorized as under:

i General Requirement:

- Check Bidder's PAN Card
- Check Bidder's GST Certificate
- Check Bidder's Certificate of Incorporation
- Power of Attorney

ii Additional Documents : (If applicable against the tender)

- Bidders general structure and organization
- Joint Ventures Agreements – To cross-check with JV Partners

- Consortium Agreements – To cross-check with Consortium Partners
- Holding/Parent/Subsidiary/Sister Subsidiary/Co-Subsidiary Company – To check the Share Holding pattern, Corporate Guarantee etc.

iii Technical Criteria

- To check Experience Proof- Completion Certificates, Reference contact verification, Original Work Order/Contract Copy and any other document(s), if called for vide BEC/BRC of the Tender.
- Health, Safety and Environmental Management Policy

iv Financial Criteria

- Line of credit, if incorporated in the tender.

Notes:

- (i) Bidder's self-declared undertakings, Audited Balance Sheet & Profit-loss statement and/or CA certificate having UDIN are not required to be verified by the TPI agency. If any documents, LOI/LOA/Contracts, etc., submitted towards BEC/BRC experience criteria are issued by Oil India Limited, such documents need not be verified by TPI agency.
- (ii) Undertaking from TPI Agency as per format (**Proforma-0**) enclosed should be submitted along with the Bid.
- (iii) **In case of clarifications sought by OIL against BEC/BRC, supporting documents (historical in nature) to those submitted in the original bid will also have to be verified from the same TPI agency which has originally verified their bid documents. OIL shall categorically mention the documents that are to be submitted with TPI verification in the clarification sought. In case the bidder fails to submit the TPI verified documents, as sought by OIL, as part of their clarification, their offer will be liable for rejection.**

PROFORMA – A

FORMAT FOR CERTIFICATE OF COMPLIANCE OF FINANCIAL CRITERIA
(ON THE OFFICIAL PAD OF THE BIDDER TO BE EXECUTED BY THE
AUTHORIZED SIGNATORY OF THE BIDDER)

Ref: Clause No. A.2 (3.0) - Financial Criteria of the BEC

Tender No.: _____

I the authorized signatory(s)
of.....(Company or firm name of address) do hereby affirm
and declare as under:-

The balance sheet/Financial Statements for the financial year _____ (as
the case may be) has actually not been audited as on the Original Bid closing Date.

Place :.....

Date :.....

authorized signatory

Signature of the

Note: *This certificate are to be issued only considering the time required for preparation of Financial Statements i.e. if the last date of preceding financial / accounting year falls within the preceding six months reckoned from the original bid closing date.*

CERTIFICATE OF ANNUAL TURNOVER & NET WORTH

TO BE ISSUED BY PRACTISING **CHARTERED ACCOUNTANTS' FIRM** ON THEIR LETTER HEAD

TO WHOM IT MAY CONCERN

This is to certify that the following financial positions extracted from the audited financial statements of M/s..... (Name of the Bidder) for the last three (3) completed accounting years up to **(as the case may be)** are correct.

YEAR	TURN OVER In INR (Rs.) Crores	NET WORTH In INR (Rs.) Crores

Annual Financial Turnover of the bidder from operations shall mean: "Aggregate value of the realization of amount made from the sale, supply or distribution of goods or on account of services rendered, or both, by the company (bidder) during a financial year" as per the Companies Act, 2013 Section 2 (91).

Net worth shall mean: "Share capital + Reserves created out of profits and securities Premium – Aggregate value of accumulated losses (excluding revaluation reserves) – deferred expenditure – Miscellaneous Expenditure to the extent not written off and carried forward Loss - Reserves created out of write back of depreciation and amalgamation"

Place:

Date:

UDIN:

Seal:

Membership Code & Registration No.:

Signature

NOTE: As per the guidelines of ICAI, every practicing CA is required to mention Unique Document Identification Number (UDIN) against each certification work done by them. Documents certified by CA without UDIN shall not be acceptable.

PROFORMA - C

**PARENT/ ULTIMATE PARENT/ HOLDING COMPANY'S CORPORATE
GUARANTEE TOWARDS FINANCIAL STANDING (Delete whichever not
applicable)**
(TO BE EXECUTED ON COMPANY'S LETTER HEAD)

DEED OF GUARANTEE

THIS DEED OF GUARANTEE executed at this day of by M/s(mention complete name) a company duly organized and existing under the laws of (insert jurisdiction/country), having its Registered Office at.....herein after called "the Guarantor" which expression shall, unless excluded by or repugnant to the subject or context thereof, be deemed to include its successors and permitted assigns.

WHEREAS M/s. Oil India Limited (hereinafter referred to as OIL) has invited offers vide their Tender No..... for.....and M/s.....(Bidder) intends to bid against the said tender and desires to have Financial support of M/s..... [Parent / Ultimate Parent/Holding Company(Delete whichever not applicable)] and whereas Parent/Ultimate Parent/Holding Company(Delete whichever not applicable) represents that they have gone through and understood the requirements of subject tender and are capable and committed to provide the Financial support as required by the bidder for qualifying and successful execution of the contract, if awarded to the bidder.

Now, it is hereby agreed by the Guarantor to give this Guarantee and undertakes as follows:

1. The Guarantor confirms that the Bidder is a 100% subsidiary of the Guarantor.
2. The Guarantor agrees and confirms to provide the Audited Annual Reports of any of the preceding 03(three) financial/accounting years reckoned from the original bid closing date.
3. The Guarantor have an annual financial turnover of minimum INR..... Cr or USD during any of the preceding 03(three) financial/ accounting years reckoned from the original bid closing date.
4. Net worth of the Guarantor is positive for preceding financial/ accounting year.
5. The Guarantor undertakes to provide financial support to the Bidder for executing the project/job, in case the same is awarded to the Bidder.
6. The Guarantor represents that:
 - (a) this Guarantee herein contained shall remain valid and enforceable till the satisfactory execution and completion of the work (including discharge of the warranty obligations) awarded to the Bidder.
 - (b) the liability of the Guarantor, under the Guarantee, is limited to the 100% of the order value between the Bidder and OIL. This will, however, be in addition to the forfeiture of the Performance Guarantee furnished by the Bidder.
 - (c) this Guarantee has been issued after due observance of the appropriate laws in force in India.

- (d) this Guarantee shall be governed and construed in accordance with the laws in force in India and subject to the exclusive jurisdiction of the courts of New Delhi, India.
- (e) this Guarantee has been given without any undue influence or coercion, and that the Guarantor has fully understood the implications of the same.
- (f) the Guarantor has the legal capacity, power and authority to issue this Guarantee and that giving of this Guarantee and the performance and observations of the obligations hereunder do not contravene any existing laws.

for and on behalf of (Parent/Ultimate Parent/ Holding Company) (Delete whichever not applicable) for and on behalf of (Bidder)

Witness:

- 1.
- 2.

Witness:

- 1.
- 2.

INTEGRITY PACT

Between

Oil India Limited (OIL) hereinafter referred to as "The Principal"

And

(Name of the bidder).....hereinafter referred to as
"The Bidder"

Preamble:

The Principal intends to award, under laid down organizational procedures, contract/s for -----. The Principal values full compliance with all relevant laws and regulations, and the principles of economic use of resources, and of fairness and transparency in its relations with its Bidder/s.

In order to achieve these goals, the Principal cooperates with the renowned international Non-Governmental Organization "Transparency International" (TI). Following TI's national and international experience, the Principal will appoint an external independent Monitor who will monitor the tender process for compliance with the principles mentioned above.

Section: 1 -Commitments of the Principal

(1) The Principal commits itself to take all measures necessary to prevent corruption and to observe the following principles:

- (i) No employee of the Principal, personally or through family members, will in connection with the tender for, or during execution of a contract, demand, take a promise for or accept, for him/herself or third person, any material or immaterial benefit which he/she is not legally entitled to.
- (ii) The Principal will, during the tender process treat all Bidders with equity and reason. The Principal will in particular, before and during the tender process, provide to all Bidders the same information and will not provide to any Bidder confidential/additional information through which the Bidder could obtain an advantage in relation to the tender process.
- (iii) The Principal will exclude from the process all known prejudiced persons.

(2) If the Principal obtains information on the conduct of any of its employees which is a criminal offence under the relevant Anti-Corruption Laws of India, or if there be a substantive suspicion in this regard, the Principal will inform the Chief Vigilance Officers and in addition can initiate disciplinary actions.

Section: 2 -Commitments of the Bidder/~~Contractor~~

(1) The Bidder commits itself to take all measures necessary to prevent corruption. During his participation in the tender process, the Bidder commits himself to observe the following principles:

- (i) The Bidder will not, directly or through any other person or firm, offer, promise or give to any of the Principal's employees involved in the tender process or the execution of the contract or to any third person any material or immaterial benefit which he/she is not legally entitled to, in order to obtain in exchange any advantage of any kind whatsoever during the tender process or during subsequent contract execution, if awarded.
- (ii) The Bidder will not enter with other Bidders into any undisclosed agreement or understanding, whether formal or informal. This applies in particular to prices, specifications, certifications, Subsidiary contracts, submission or non-submission of bids or any other actions to restrict competitiveness or to introduce cartelization in the bidding process.
- (iii) The Bidder(s) will not commit any offence under the relevant Anticorruption Laws of India, further, the Bidder(s) will not use improperly, for purposes of competition or personal gain, or pass on to others, any information or document provided by the Principal as part of the business relationship, regarding plans, technical proposals and business details, including information contained or transmitted electronically.
- (iv) The Bidder will, when presenting his bid, disclose any and all payments he has made, is committed to or intends to make to agents, brokers or any other intermediaries in connection with the award of the contract.
- (v) Bidders to disclose any transgressions with any other public/government organization that may impinge on the anti-corruption principle. The date of such transgression, for the purpose of disclosure by the bidders in this regard, would be the date on which cognizance of the said transgression was taken by the competent authority. The period for which such transgressions (s) is/are to be reported by the bidders shall be the last **three years** to be reckoned from date of bid submission. The transgression (s), for which cognizance was taken even before the said period of three years, but are pending conclusion, shall also be reported by the bidders.

- (vi) The Bidder(s) of foreign origin shall disclose the name and address of the Agents/ representatives in India, if any. Similarly, the Bidder(s) of Indian Nationality shall furnish the name and address of the foreign principals, if any. Further, all the payments made to the Indian agent/ representative have to be in India Rupees only.
 - (vii) Bidders not to pass any information provided by Principal as part of business relationship to others and not to commit any offence under PC/ IPC Act;
- (2) The Bidder will not instigate third persons to commit offences outlined above or be an accessory to such offences.
- (3) The Bidder signing Integrity Pact shall not approach the Courts while representing the matters to IEMs and he/she will await their decision in the matter.

Section 3 -Disqualification from tender process and exclusion from future Contracts

If the Bidder, before contract award has committed a transgression through a violation of Section 2 or in any other form such as to put his reliability or risibility as Bidder into question, the Principal is entitled to disqualify the Bidder from the tender process, for such reason.

1. If the Bidder has committed a transgression through a violation of Section 2 such as to put his reliability or credibility into question, the Principal is entitled also to exclude the Bidder from future contract award processes. The imposition and duration of the exclusion will be determined by the severity of the transgression. The severity will be determined by the circumstances of the case, in particular the number of transgressions, the position of the transgressions within the company hierarchy of the Bidder and the amount of the damage. The exclusion will be imposed for a minimum of 6 months and maximum of 2 years.
2. The Bidder accepts and undertakes to respect and uphold the Principal's Absolute right to resort to and impose such exclusion and further accepts and undertakes not to challenge or question such exclusion on any ground, including the lack of any hearing before the decision to resort to such exclusion is taken. This undertaking is given freely and after obtaining independent legal advice.
3. If the Bidder can prove that he has restored/recouped the Damage caused by him and has installed a suitable corruption prevention system, the Principal may revoke the exclusion prematurely.
4. A transgression is considered to have occurred if in light of available evidence, no reasonable doubt is possible.
5. Integrity Pact, in respect of a particular contract, shall be operative from the date Integrity Pact is signed by both the parties or as mentioned in Section 9 - Pact Duration whichever is later. Any violation of the same would entail disqualification of the bidders and exclusion from future business dealings.

Section 4 -Compensation for Damages

(1) If the Principal has disqualified the Bidder from the tender process prior to the award according to Section 3, the Principal is entitled to demand and recover from the Bidder liquidated damages equivalent to Earnest Money Deposit / Bid Security.

(2) The bidder agrees and undertakes to pay the said amounts without protest or demur subject only to condition that if the Bidder can prove and establish that the exclusion of the Bidder from the tender process has caused no damage or less damage than the amount or the liquidated damages, the Bidder shall compensate the Principal only to the extent of the damage in the amount proved.

Section 5 -Previous transgression

(1) The Bidder declares that no previous transgression occurred in the last 3 years with any other company in any country conforming to the TI approach or with any other Public Sector Enterprise in India that could justify his exclusion from the tender process.

(2) If the Bidder makes incorrect statement on this subject, he can be disqualified from the tender process for such reason.

Section: 6 -Equal treatment of all Bidders/Contractor/Subcontractors

(1) The Principal will enter into Pacts on identical terms with all bidders.

(2) The Bidder undertake(s) to procure from all subcontractors a commitment in conformity with this Integrity Pact. The Bidder shall be responsible for any violation(s) of the provisions laid down in this agreement/Pact by any of its subcontractors/sub-vendors.

(3) The Principal will disqualify from the tender process all bidders who do not sign this Pact or violate its provisions.

Section: 7 -Criminal charges against violating Bidders/Contractors/ Subcontractors

If the Principal obtains knowledge of conduct of a Bidder, Contractor or Subcontractor, or of an employee or a representative or an associate of a Bidder, Contractor or Subcontractor, which constitutes corruption, or if the Principal has substantive suspicion in this regard, the Principal will inform the Vigilance Office.

Section: 8 -External Independent Monitor/Monitors

(1) The Principal appoints competent and credible Independent External Monitor (IEM) for this Pact.

(2) The Monitor is not subject to instructions by the representatives of the parties and performs his functions neutrally and independently. He reports to the Chairperson of the Board of the Principal.

(3) The Bidder accepts that the Monitor has the right to access without restriction to all Project documentation of the Principal including that provided by the Bidder. The Bidder will also grant the Monitor, upon his request and demonstration of a valid interest, unrestricted and unconditional access to his project documentation. The same is applicable to Subcontractors. The Monitor is under contractual obligation to

treat the information and documents of the Bidder/Contractor/Subcontractor with confidentiality.

(4) The Principal will provide to the Monitor sufficient information about all meetings among the parties related to the Project provided such meetings could have an impact on the contractual relations between the Principal and the Bidder. The parties offer the Monitor the option to participate in such meetings.

(5) As soon as the Monitor notices, or believes to notice, a violation of this agreement, he will so inform the Management of the Principal and request the Management to discontinue or heal the violation, or to take other relevant action. The monitor can in this regard submit non-binding recommendations. Beyond this, the Monitor has no right to demand from the parties that they act in a specific manner, refrain from action or tolerate action. However, the Independent External Monitor shall give an opportunity to the bidder to present its case before making its recommendations to the Principal.

(6) The Monitor will submit a written report to the Chairperson of the Board of the Principal within 8 to 10 weeks from the date of reference or intimation to him by the 'Principal' and, should the occasion arise, submit proposals for correcting problematic situations.

(7) If the Monitor has reported to the Chairperson of the Board a Substantiated suspicion of an offence under relevant Anti-Corruption Laws of India, and the Chairperson has not, within reasonable time, taken visible action to proceed against such offence or reported it to the Vigilance Office, the Monitor may also transmit this information directly to the Central Vigilance Commissioner, Government of India.

(8) The word 'Monitor' would include both singular and plural.

(9) In case of any complaints referred under IP Program, the role of IEMs is advisory and the advice of IEM is non-binding on the Organization. However, as IEMs are invariably persons with rich experience who have retired as senior functionaries of the government, their advice would help in proper implementation of the IP.

Section:9 -Pact Duration

This Pact begins when both parties have legally signed it. It expires for the Contractor 12 months after the last payment under the respective contract, and for all other Bidders 6 months after the contract has been awarded.

If any claim is made/ lodged during this time, the same shall be binding and continue to be valid despite the lapse of this pact as specified above, unless it is discharged/determined by Chairperson of the Principal.

Section:10 -Other provisions

(1) This agreement is subject to Indian Law. Place of performance and jurisdiction is the Registered Office of the Principal. The Arbitration clause provided in the main tender document / contract shall not be applicable for any issue / dispute arising under Integrity Pact.

(2) Changes and supplements as well as termination notices need to be made in writing. Side agreements have not been made.

(3) In case of a joint venture, all the partners of the joint venture should sign the Integrity Pact. In case of sub-contracting, the principal contractor shall be solely responsible for the adherence to the provisions of IP by the sub-contractor(s).

(4) Should one or several provisions of this agreement turn out to be invalid, the remainder of this agreement remains valid. In this case, the parties will strive to come to an agreement to their original intentions.

TUHIN ROY For the Principal For the Bidder/Contractor
Date :	Witness 1:
Place :	Witness 2:

PROFORMA - E(I)

UNDERTAKING TOWARDS COMPLIANCE OF PROVISIONS FOR RESTRICTIONS ON PROCUREMENT FROM A BIDDER OF A COUNTRY WHICH SHARES LAND BORDER WITH INDIA

(To be typed on the letter head of the bidder)

Ref. No _____

Date: _____

Tender No. _____ Date: _____

OIL INDIA LIMITED
MATERIALS DEPARTMENT,
DULIAJAN, ASSAM, INDIA

Dear Sirs,

We, M/s _____, have read the clause regarding restrictions on procurement from a bidder of a country which shares a land border with India; we certify that we are not from such a country/or if from such a country, have been registered with the Competent Authority. We hereby certify that we fulfil all requirements in this regard and are eligible to be considered. *[wherever applicable, evidence of valid registration by the Competent Authority shall be attached]*

Yours faithfully,
For (type name of the firm here)

Signature of Authorised Signatory

Name:

Designation:

Phone No.

Place:

Date:

(Affix Seal of the Organization here, if applicable)

PROFORMA - E(II)

UNDERTAKING FOR WORKS INVOLVING POSSIBILITY OF SUB-CONTRACTING

(To be typed on the letter head of the bidder)

Ref. No _____

Date: _____

Tender No. _____ Date: _____

**OIL INDIA LIMITED
MATERIALS DEPARTMENT,
DULIAJAN, ASSAM, INDIA**

Dear Sirs,

We, M/s _____, have read the clause regarding restrictions on procurement from a bidder of a country which shares a land border with India and on sub-contracting to contractors from such-countries, we certify that we are not from such a country/or if from such a country, have been registered with the Competent Authority and will not sub-contract any work to a contractor from such countries unless such contractor is registered with the Competent Authority. We hereby certify that we fulfil all requirements in this regard and is eligible to be considered. *[wherever applicable, evidence of valid registration by the Competent Authority shall be attached]*

Yours faithfully,
For (type name of the firm here)

Signature of Authorized Signatory

Name:

Designation:

Phone No.

Place:

Date:

(Affix Seal of the Organization here, if applicable)

PROFORMA – E(III)

ADDITIONAL UNDERTAKING BY BIDDER IN CASES OF SPECIFIED TRANSFER OF TECHNOLOGY

(To be typed on the letter head of the bidder)

Ref. No _____

Date: _____

Tender No. _____ Date: _____

**OIL INDIA LIMITED
MATERIALS DEPARTMENT,
DULIAJAN, ASSAM, INDIA**

We, M/s _____, have read the clause regarding restrictions on procurement from a bidder having Transfer of Technology (ToT) arrangement. We certify that we do not have any ToT arrangement requiring registration with the competent authority.

OR

We, M/s _____, have read the clause regarding restrictions on procurement from a bidder having Transfer of Technology (ToT) arrangement. We certify that we have valid registration to participate in this procurement. *[Evidence of valid registration by the Competent Authority shall be attached]*

Yours faithfully,
For (type name of the firm here)

Signature of Authorised Signatory

Name:
Designation:
Phone No.
Place:
Date:

(Affix Seal of the Organization here, if applicable)

PROFORMA - F

FORMAT FOR PERFORMANCE BANK GUARANTEE

To,
GENERAL MANAGER - MATERIALS (HOD)
OIL INDIA LIMITED, MATERIALS DEPARTMENT,
DULIAJAN, ASSAM, INDIA, PIN - 786602

WHEREAS.....
.....(Name and address of Contractor) (hereinafter called "Contractor") had undertaken, in pursuance of Contact No..... to execute (Name of Contract and Brief Description of the Work) (hereinafter called "the Contract").

AND WHEREAS it has been stipulated by you in the said Contract that the Contractor shall furnish you with a Bank Guarantee as security for compliance with Contractor's obligations in accordance with the Contract.

AND WHEREAS we (May incorporate the Bank Name) have agreed to give the Contractor such a Bank Guarantee; NOW THEREFORE we hereby affirm that we are Guarantors on behalf of the Contractor, up to a total of (Amount of Guarantee in figures)..... (in words), such amount being payable in the types and proportions of currencies in which the Contract price is payable, and we undertake to pay you, upon your first written demand and without cavil or arguments, any sum or sums within the limits of guarantee sum as aforesaid without your needing to prove or to show grounds or reasons for your demand for the sum specified therein. We hereby waive the necessity of your demanding the said debt from the Contractor before presenting us with the demand.

We further agree that no change or addition to or other modification of the terms of the Contract or the work to be performed thereunder or of any of the Contract

documents which may be made between you and the Contractor shall in any way cease us from any liability under this guarantee, and we hereby waive notice of such change, addition or modification.

This guarantee is valid until theday of.....

The details of the Issuing Bank and Controlling Bank are as under:

- A. Issuing Bank:
BANK FAX NO:
BANK EMAIL ID:
BANK TELEPHONE NO:
IFSC CODE OF THE BANK:

- B. Controlling Office:
Address of the Controlling Office of the BG issuing Bank:
Name of the Contract Person at the Controlling Office with Mobile No. and e-mail address:

Notwithstanding anything contained herein:

- (a) Our liability under this Bank Guarantee shall is restricted up to Rs.....
- (b) This guarantee shall be valid till
- (c) We are liable to pay the guarantee amount or any part thereof under this Bank Guarantee only and only if you serve upon us a written claim or demand on or before(Date of Expiry of BG PLUS one year claim period).
- (d) At the end of the claim period that is on or after.....(Date of expiry of.....the Bank Guarantee Plus Minimum of 1 year claim period shall be stipulated) all your rights under this Guarantee shall stand extinguished and we shall be discharged from all our liabilities under this Guarantee irrespective of receipt of original Bank Guarantee duly discharged, by Bank.

Name of the Contact Person at the Controlling Office with Mobile No. and e-mail address:

SIGNATURE AND SEAL OF THE GUARANTORS.....

Designation:.....

Name of the Bank:..... of the Bank:.....

Address:.....

UNDERTAKING BY VENDOR ON SUBMISSION OF BANK GUARANTEE

To,

Oil India Limited,
Materials Department,
Duliajan, Assam - 786602

We, M/s..... are submitting the Bid Security/Performance Security (strike out whichever not applicable) in favour of Oil India Limited, Duliajan in the form of bank guarantee bearing Reference No.....for an amount of INR.....valid up to as per terms and conditions of Tender / Contract No.....

BG issuing bank details:

Bank:	
Branch:	
IFS Code:	
Contact Details	
E-mail Addresses:	Mobile No.: Telephone No.: Fax No.:

Correspondence Address	
H No/Street/City:	State:
	Country:
	Pin Code:

Declaration:

We have arranged to send the confirmation of issuance of the bank guarantee via SFMS portal through our bank using the details mentioned in the tender and hereby confirming the correctness of the details mentioned.

Authorized Signature:

Name:

Vendor Code:

Email ID:

Mobile No.:

Enclosure: Original bank guarantee

PROFORMA – G (A)

BID SECURITY FORM

To:
M/s. OIL INDIA LIMITED,
MATERIALS DEPARTMENT

Whereas.....(hereinafter called 'the Bidder') has submitted their Bid No. dated..... against OIL INDIA LIMITED, DULIAJAN, ASSAM, INDIA (hereinafter called the Purchaser) 's Tender No.for the supply of
... (hereinafter called 'the Bid') KNOW ALL MEN by these presents.

That we ofhaving our registered office at (hereinafter called 'the Bank') are bound unto the Purchaser, in the sum of for

which payment well and truly to be made to the said Purchaser, the Bank binds itself, its successors and assigns by these presents.

Sealed with the said Bank thisday of

THE CONDITIONS of this obligation are:

1. If the Bidder withdraws their Bid during the period of Bid validity specified by the Bidder,
or
2. If the Bidder, having been notified of the acceptance of their bid by the Purchaser during the period of bid validity:
 - a) fails or refuses to accept the order; or
 - b) fails or refuses to furnish the performance securityor
3. If the Bidder furnishes fraudulent document/information in their bid.

We undertake to pay to the Purchaser up to the above amount upon receipt of their first written demand (by way of letter /fax/Email) without the Purchaser having to substantiate their demand, provided that in their demand the Purchaser will note that the amount claimed by it is due to it owing to the occurrence of any of the conditions, specifying the occurred condition or conditions.

This guarantee will remain in force up to and including (Bidder to indicate specific date as mentioned in the tender), and any demand in respect thereof should reach the Bank not later than the above date.

The details of the Issuing Bank and Controlling Bank are as under:

A. Issuing Bank:

BANK FAX NO:
BANK EMAIL ID:
BANK TELEPHONE NO.:
IFSC CODE OF THE BANK:

B. Controlling Office:

Address of the Controlling Office of the BG issuing Bank:
Name of the Contact Person at the Controlling Office with Mobile No. and e-mail address:

Notwithstanding anything contained herein:

- a) Our liability under this Bank Guarantee shall is restricted up to Rs
- b) This guarantee shall be valid till
- c) We are liable to pay the guarantee amount or any part thereof under this Bank Guarantee only and only if you serve upon us a written claim or demand on

or before (Date of Expiry of BG PLUS one year claim period).

d) At the end of the claim period that is on or after (Date of expiry of the Bank Guarantee Plus Minimum of 1 year claim period shall be stipulated) all your rights under this Guarantee shall stand extinguished and we shall be discharged from all our liabilities under this Guarantee irrespective of receipt of original Bank Guarantee duly discharged, by Bank.

Name of the Contact Person at the Controlling Office with Mobile No. and e-mail address:

SIGNATURE AND SEAL OF THE GUARANTORS _____

Designation: _____

Name of Bank: _____

Address: _____

Date: _____

Place: _____

PROFORMA – G (B)

**BID SECURITY
DECLARATION**

To,

M/s. Oil India Limited

.....,
.....

Sub:

.....

...

Tender

No:.....

Dear Sir,

After examining/reviewing provisions of above referred tender documents (including all corrigendum/ Addenda), we M/s. (Name of Bidder) have submitted our offer/bid no.....

We, M/s (Name of Bidder) hereby understand that, according to your conditions, we are submitting this Declaration for Bid Security.

We understand that we will be put on watch list/holiday/banning list (as per policies of OIL INDIA in this regard), if we are in breach of our obligation(s) as per following:

- (a) have withdrawn/modified/amended, impairs or derogates from the tender, my/our Bid during the period of bid validity specified in the form of Bid; or
- (b) having been notified of the acceptance of our Bid by the OIL INDIALIMITED during the period of bid validity:
 - (i) fail or refuse to execute the Contract, if required, or
 - (ii) fail or refuse to furnish the Contract Performance Security, in accordance provisions of tender document.
 - (iii) Fail or refuse to accept 'arithmetical corrections' as per provision of tender document.
- (c) having indulged in corrupt/fraudulent/collusive/coercive practice as per procedure.

Place:
Bidder]
Date:

[Signature of Authorized Signatory of

Name:
Designation:
Seal:

PROFORMA - H

FORMAT OF UNDERTAKING BY BIDDERS TOWARDS SUBMISSION OF AUTHENTIC INFORMATION/DOCUMENTS

(To be typed on the letter head of the bidder)

Ref. No _____

Date _____

To,

**General Manager (Materials)
Materials Department
Oil India Limited, Duliajan**

Sub: Undertaking of authenticity of information/documents submitted
Ref: Your tender No. _____ Dated _____

Sir,

With reference to our quotation no. dated..... against your above-referred tender, we hereby undertake that no fraudulent information/documents have been submitted by us.

We take full responsibility for the submission of authentic information/documents against the above cited bid.

We also agree that, during any stage of the tender/contract agreement, in case any of the information/documents submitted by us are found to be false/forged/fraudulent, OIL has right to reject our bid at any stage including forfeiture of our EMD and/or PBG and/or cancel the award of contract and/or carry out any other penal action on us, as deemed fit.

Yours faithfully,
For (type name of the firm here)

Signature of Authorised Signatory

Name:
Designation:
Phone No.
Place:
Date:

(Affix Seal of the Organization here, if applicable)

ANNEXURE - VI

BID EVALUATION MATRIX (TECHNICAL) (TO BE FILLED IN BY BIDDER DULY SIGNED)
TECHNICAL SPECIFICATIONS

ANNEXURE - VII

**BID EVALUATION MATRIX (BID REJECTION CRITERIA)
(TO BE FILLED IN BY BIDDER DULY SIGNED)**

BID EVALUATION CRITERIA

Claus e Num ber	DESCRIPTION	BIDDER'S RESPONS E (Complied / Not Complied /Deviation /Not Applicable)	TO BE FILLED BY THE BIDDER Relevant Location of their Bid to support the remarks / compliance (Reference of Document name / Serial number / Page number of bid for documentary evidence)
A.1	BRC - TECHNICAL		

PROFORMA - I

PROFORMA OF AUTHORISATION LETTER FOR ATTENDING TENDER OPENING

Ref No.

Date

TO,
GM- MATERIALS
MATERIALS DEPARTMENT
P.O. DULIAJAN, PIN-786602

DIST. DIBRUGARH, ASSAM, INDIA

Dear Sir,

Sub: OIL's Tender No. _____

For _____ Mr _____ has been authorized to be present at the time of opening of above tender due on _____ at _____ on my/our behalf.

Yours faithfully

Signature of Bidder

Name: _____ Designation : _____

For & on behalf of :

Copy to: Mr _____ for information and for production before the (MM) _____ at the opening of bids.

PROFORMA – J

EXCEPTION / DEVIATION PROFORMA

OIL expects the bidders to fully accept the terms and conditions of the bidding documents. However, should the bidder experience some exception and deviations to the terms of the bidding documents, the same should be indicated here and put in unpriced bid. In order to be considered responsive, Bidder's offer must specifically include the following statement :

(a) We certify that our offer complies with all NIT requirements and specifications without any deviations.

Or

(b) We certify that our offer complies with all NIT requirements and specifications with the following deviations :

Clause No. of Bidding Document	Full compliance/ not agreed	Exception/ deviations	Remarks
		taken by the Bidders	

Signature of the Bidder

Name :

Seal of the company

PROFORMA – K

UNDERTAKING FOR LOCAL CONTENT
(To be submitted in the letter head of the bidder).

Tender No. _____

We, _____ (Name of the bidder) have submitted Bid against Tender No. _____-dated _____ for _____.

We hereby undertake that we meet the mandatory minimum local content requirement as per the provision of Public Procurement (Preference to Make in India) Order, 2017 of Department for Promotion of Industry and Internal Trade (DPIIT), Govt. of India as revised vide Order No. P45021/2/2017-PP (BE-II) dated 16th September 2020 (and as amended time to time) with modifications as notified vide MoP&NG Order No. FP-20013/2/2017-

FP-PNG-Part (4) (E-41432) dated 26th April 2022 (including subsequent amendments thereof, if any). The percentage of Local Content is _____%.

We further declare that the percentage of Local content for the tendered Goods/Services has been calculated in conjunction with the directive issued by Ministry of Petroleum and Natural Gas vide notification no. FP-20013/2/2017-FP-PNG-Part (4) (E-41432) dated 26.03.2024.

For and on behalf of _____
Authorized signatory _____
Name _____
Designation _____
Contact No. _____

PROFORMA - L

LETTER OF AUTHORITY

TO,
GM- MATERIALS
MATERIALS DEPARTMENT
P.O. DULIAJAN, PIN-786602
DIST. DIBRUGARH, ASSAM, INDIA

Dear Sir,

Sub: OIL's Tender No. _____

We _____ of _____ confirm that Mr. _____ (Name and address) is authorised to represent us to Bid, negotiate and conclude the agreement on our behalf with you against OIL's Tender No. _____ for any commercial /Legal purpose etc.

We confirm that we shall be bound by all and whatsoever our said representative shall commit.

Authorised Person's Signature: _____
Name: _____
Designation: _____

Yours faithfully,
Signature:
Name & Designation _____
For & on behalf of _____

Note: This letter of authority shall be on printed letter head of the Bidder and shall be signed by a person competent and having the power of attorney (power of attorney shall be annexed) to bind such Bidder.

Proforma – M
UNDERTAKING FOR BIDDERS FINANCIAL STANDING

TO,
GM- MATERIALS
MATERIALS DEPARTMENT
P.O. DULIAJAN, PIN-786602
DIST. DIBRUGARH, ASSAM, INDIA

Dear Sir,

Sub: OIL's Tender No. _____

We, _____ (Name of the bidder) have submitted Bid against Tender No. _____ dated _____. We hereby undertake that we are not under liquidation, court receivership or similar proceedings, we are not bankrupt.

For and on behalf of _____
Authorized signatory _____
Name _____
Designation _____
Contact No. _____

Proforma – N1

DECLARATION THAT BIDDER IS NOT UNDER HOLIDAY LIST/DELISTED/BLACKLISTED/DEBARRED

To,
GM- MATERIALS
MATERIALS DEPARTMENT
P.O. DULIAJAN, PIN-786602
DIST. DIBRUGARH, ASSAM, INDIA

TENDER NO. _____

Tender Description: _____

Sub: Undertaking/Declaration regarding Holiday List, debarment etc.

Ref: Tender No. _____

- a) We, _____ (Name of the bidder) solemnly affirm that we have read and understood OIL's Banning Policy as available at OIL's website <https://www.oil-india.com/banning-policy> and accept the Banning Policy in toto without any demur, protest, reservations and agree to be bound by the said Policy.
- b) We, hereby declare that neither our company nor any of its allied concerns, partners or associates or directors or proprietors involved in any capacity, are currently put on holiday list/banning list by OIL debaring us/them from carrying on business dealings with OIL.
- c) We, also hereby declare that neither our company nor any of its allied concerns, partners or associates or directors or proprietors involved in any capacity, have not been involved in any previous transgressions in the last 3 years with any other company in any country conforming to the TI (Transparency International) approach or with any other Public Sector Enterprise in India that could justify his exclusion from the tender process.
- d) We, disclose the following allied concerns, partners or associates or directors or proprietors involved in any capacity in terms of the definition of Allied firms given in the "Banning Policy" of Oil India Limited:

Sl. No.	Name	Address	PAN No.	GST No.	OIL Vendor Code

--	--	--	--	--	--

Place: _____

Date: _____

 (Name & Signature of the authorized signatory of the bidder)

Proforma - N2

PROFORMA OF DECLARATION OF NCLT / NCLAT / DRT / DRAT / COURT RECEIVERSHIP / LIQUIDATION

TO,
 GM- MATERIALS
 MATERIALS DEPARTMENT
 P.O. DULIAJAN, PIN-786602
 DIST. DIBRUGARH, ASSAM, INDIA

Dear Sir,

Sub: OIL's Tender No. _____

We hereby declare that we are not undergoing insolvency resolution process or liquidation or bankruptcy proceeding as on date. In respect of corrupt or fraudulent practice (s), except as indicated below:-

(Here give particulars of blacklisting or holiday listing and /or inquiry and in the absence thereof state "NIL")

It is understood that if this declaration is found to be false in any particular, Oil India Limited shall have the right to reject my / our bid, and if the bid has resulted in a contract, the contract is liable to be terminated without prejudice to any other right or remedy (include blacklisting or holiday listing) available to Oil India Limited.

For and on behalf of _____
 Authorized signatory _____
 Name _____
 Designation _____
 Contact No. _____

Proforma - O

**PROFORMA FOR UNDERTAKING FROM THIRD PARTY DOCUMENT VERIFICATION
INSPECTION AGENCY**

(To be submitted on official letter head)

TO,
GM- MATERIALS
MATERIALS DEPARTMENT
P.O. DULIAJAN, PIN-786602
DIST. DIBRUGARH, ASSAM, INDIA

Sir

SUB : OIL's tender No.

M/s _____ having registered office at _____ intend to participate in the above referred tender of OIL INDIA LIMITED.

The tender conditions stipulated that the bidder shall submit documents pertaining to Bid Evaluation Criteria / Bid Rejection Criteria (BEC / BRC), duly verified and certified by designated independent Third Party Document Verification Inspection Agency.

In this regard , we hereby certify that copies of documents pertaining to Bid Evaluation Criteria / Bid Rejection Criteria (BEC / BRC), submitted to us by the bidder. M/s _____ have been verified and certified by us with originals and found to be genuine and authentic. We have signed and stamped on the copies of all the verified and certified documents having _____ nos. pages.

Note: In the event of any requirement, OIL reserves the right to ask the inspection agencies to verify the documents with source, if required at no extra cost to OIL.

Thanking you,

Authorized Person's Signature: _____

Name: _____

Proforma – P

FORMAT FOR BANK GUARANTEE LINKED WITH ADVANCE PAYMENT

TO,
OIL INDIA LIMITED, DULIAJAN - 786 602 ASSAM, INDIA

WHEREAS.....(Name of the Seller)
(herein after called 'the Seller') has undertaken, in pursuance of Order
No.....dated...../...../..... to
supply..... (description of
Goods and Services) hereinafter called 'the Contract'.

AND WHEREAS it has been stipulated by you in the said Contract that the Seller shall furnish you with a Bank Guarantee from a recognized Bank for the sum specified therein as security for advance payment in accordance with the Contract.

AND WHEREAS we have agreed to give the Seller a Guarantee:

THEREFORE, we hereby affirm that we are Guarantors responsible to you, on behalf of the seller, upto a total

of.....
(Amount of the Guarantee in words and figures) and we undertake to pay you, upon first written demand declaring the Seller to be in default under the contract and without cavil or argument and sum or sums within the limits of.....
..... (Amount of Guarantee) as aforesaid, without your needing to prove or to show grounds or reasons for your demand or the sum specified therein.

This Guarantee is valid until the day of

The details of the issuing bank and controlling bank are as under:

A. Issuing Bank

- 1. Full address of the bank:
- 2. Email address of the bankers:
- 3. Mobile nos. of the contact persons:

B. Controlling Office

- 1. Address of the controlling office of the BG issuing banks:
- 2. Name of the contact persons at the controlling office with their mobile nos. and email address:

Signature & Seal of the guarantors

Date

..... Witness

Proforma – Q

PROFORMA OF “INSURANCE SURETY BOND” FOR “BID SECURITY”

(To be stamped in accordance with the Stamp Act)

**To Insurance Surety Bond (ISB) No.
Date of ISB**

**M/s OIL INDIA ISB Valid up to (Expiry date)
LIMITED,**

Address:

PIN- XXXXXXXX

**Claim period up to (indicate date of
expiry of claim period which
includes minimum three months
from the expiry date)**

**Stamp Sl. No./e-Stamp Certificate
No.**

WHEREAS, (Name of Bidder) _____ (hereinafter called "the Bidder") has submitted their offer Dated _____ for the provision of certain services (hereinafter called "the Bid") against OIL INDIA LIMITED, Duliajan, Assam, India (hereinafter called the Company's) Tender No. _____ KNOW ALL MEN BY these presents that we _____ (Name & address of the "Insurer") _____ having our registered office at _____ (hereinafter called " Insurer "), its successors and assignees, unconditionally and irrevocably undertake to pay forthwith to the Company an amount of Rs. (Rupees only) (hereinafter referred to as the "Surety Bond") as our primary obligation without any demur, reservation, recourse, contest or protest and without reference to the Bidder, if the Bidder shall fail to fulfil or comply with all or any of the conditions mentioned below or referred in the Tender document in this regards.

Any such written demand made by the Company stating that the Bidder is in default of the due and faithful fulfilment and compliance with the aforesaid conditions shall be final, conclusive and binding on the Surety, Insurer.

SEALED with the said Insurer this _____ day of ____20 _____

THE CONDITIONS of these obligations are:

1. If the Bidder withdraws their Bid within its original/extended validity; or
2. The Bidder modifies/ revises their bid suomoto; or
3. The Bidder does not accept the contract; or
4. The Bidder does not furnish Performance Security Deposit within the stipulated time as per tender/contract; or
5. If it is established that the Bidder has submitted fraudulent documents or has indulged into corrupt and fraudulent practice.

NOW, THEREFORE, the Surety Insurer hereby, unconditionally and irrevocably, guarantees and affirms as follows:

1. The Surety Bond shall not be affected by any change in the constitution or winding up of the Bidder or the Surety Insurer or any absorption, merger or amalgamation of the Bidder or the Surely Insurer with any other person.
2. In order to give full effect to this Surety Bond, the Company shall be entitled to treat the Surety Insurer as the principal debtor:
3. The Surety Insurer declares that it has the power to issue this Surety Bond and discharge the obligations contemplated herein, the undersigned is duly authorised and has full power to execute this Surety Bond for and on behalf of the Surety Insurer.
4. Notwithstanding anything contained herein:

a) The Insurer's liability under this Insurance Surety Bond shall not exceed (currency in figures) (currency in words only).

b) This Insurance Surety Bond shall remain in force upto _____ and any extension(s) thereof; and

c) The Surety insurer shall be released and discharged from all liability under this Insurance Surety Bond unless a written claim or demand is issued to the insurer on or before the midnight of (indicate date of expiry of claim period which includes minimum **three months** from the expiry of this Insurance Surety Bond) and any extension(s) thereof. If a claim has been received by us within the said date, all the rights of Company under this Insurance Surety Bond shall be valid and shall not cease until we have satisfied that claim.

In witness whereof the insurer, through its authorized officer, has set its hand and stamp on this

_____ day of _____ 20__ at _____.

Witness:

Issuing Authority:

.....
.....

(Signature)

Signature of the Authorised Signatory)

.....
.....

(Name)

(Name)

.....
.....

(Designation & official address)

(Designation with Insurer Stamp)

Authorised Vide

Power of Attorney No.....

Date.....

INSTRUCTIONS FOR FURNISHING "BID SECURITY DEPOSIT" BY "INSURANCE SURETY BOND"

a) The Insurance Surety Bond shall be from an Insurer as per guidelines issued by Insurance Regulatory and Development Authority of India (IRDAI).

b) The Company shall be the Creditor, the Bidder shall be the Principal debtor and the Insurance company/Insurer shall be the Surety in respect of the Insurance Surety Bond to be issued by the Insurer.

c) The Insurance Surety Bond should be on Non-Judicial stamp paper/e-stamp paper of appropriate value as per Stamp Act prevailing in the state(s) where the Insurance Surety

Bond is submitted or is to be acted upon or the rate prevailing in State where the Insurance Surety Bond is executed, whichever is higher. The Stamp Paper/e-stamp paper shall be purchased in the name of Bidder/Insurer issuing the Insurance Surety Bond.

d) The expiry date and values should be arrived at in accordance with instructions provided in the "Forwarding Letter" of the Tender.

e) The Insurance Surety Bond by bidders will be given from Insurer as specified in the Tender.

f) A letter from the issuing insurer of the requisite Insurance Surety Bond confirming that the said Insurance Surety Bond / all future communication relating to the Insurance Surety Bond shall be forwarded to the Purchaser at its address as mentioned at "ITB".

g) Bidder must indicate the full postal address of the Insurer along with the Insurer's E-mail / Phone from where the Insurance Surety Bond has been issued.

h) Bidder must indicate Name, Address, Contact number and official Email ID of the Controlling Office of the Surety Issuing Branch or any web portal link, from whom / where the Surety Bond can be got confirmed by the Company.

PROFORMA OF "INSURANCE SURETY BOND" FOR "PERFORMANCE SECURITY"

(To be stamped in accordance with the Stamp Act)

To	Insurance Surety Bond (ISB) No.
M/s OIL INDIA LIMITED,	Date of ISB
	ISB Valid up to (Expiry date)

Address:

PIN- XXXXXXXX

Claim period up to (indicate date of expiry of claim period which includes minimum three months from the expiry date)

Stamp Sl. No./e-Stamp Certificate No.

WHEREAS, (Name and address of Contractor) _____ (hereinafter called "Contractor") had undertaken, in pursuance of Contact No. _____ to execute (Name of Contract and Brief Description of the Work) _____ (hereinafter called "the Contract").

AND WHEREAS it has been stipulated by you in the said Contract that the Contractor shall furnish you with an Insurance Surety Bond (ISB) as security for compliance with Contractor's obligations in accordance with the Contract.

AND WHEREAS we (May incorporate the Insurer) have agreed to give the Contractor such an Insurance Surety Bond; NOW THEREFORE we hereby affirm that we are Insurer on behalf of the Contractor, up to a total of (Amount of ISB in figures) _____ (in words _____), such amount being payable in the types and proportions of currencies in which the Contract price is payable, and we, undertake to pay you, upon your first written demand stating the default/breach committed by the Contractor without cavil or arguments, any sum or sums within the limits of guarantee sum as aforesaid without your needing to prove or to show grounds or reasons for your demand for the sum specified therein. We hereby waive the necessity of your demanding the said debt from the Contractor before presenting us with the demand.

We further agree that no change or addition to or other modification of the terms of the Contract or the work to be performed thereunder or of any of the Contract documents which may be made between you and the Contractor shall in any way cease us from any liability under this ISB, and we hereby waive notice of such change, addition or modification.

NOW, THEREFORE, the Surety Insurer hereby, unconditionally and irrevocably, guarantees and affirms as follows:

1. The Surety Bond shall not be affected by any change in the constitution or winding up of the Contractor or the Surety Insurer or any absorption, merger or amalgamation of the Contractor or the Surety Insurer with any other person.

2. In order to give full effect to this Surety Bond, the Company shall be entitled to treat the Surety Insurer as the principal debtor.

3. The Surety Insurer declares that it has the power to issue this Surety Bond and discharge the obligations contemplated herein, the undersigned is duly authorised and has full power to execute this Surety Bond for and on behalf of the Surety Insurer.

4. Notwithstanding anything contained herein:

a) The Insurer's liability under this Insurance Surety Bond shall not exceed (currency in figures) (currency in words only)

b) This Insurance Surety Bond shall remain in force upto _____ and any extension(s) thereof; and

c) The Surety insurer shall be released and discharged from all liability under this Insurance Surety Bond unless a written claim or demand is issued to the insurer on or before the midnight of

..... (indicate date of expiry of claim period which includes minimum **three months** from the expiry of this Insurance Surety Bond) and any extension(s) thereof. If a claim has been received by us within the said date, all the rights of Company under this Insurance Surety Bond shall be valid and shall not cease until we have satisfied that claim.

In witness whereof the insurer, through its authorized officer, has set its hand and stamp on this

_____ day of _____ 20__ at _____.

Witness:

Issuing Authority:

.....
.....

(Signature)

Signature of the Authorised Signatory)

.....
.....

(Name)

(Name)

.....
.....

(Designation & official address)

(Designation with Insurer Stamp)

Authorised Vide

Power of Attorney No.....

Date.....

**INSTRUCTIONS FOR FURNISHING "PERFORMANCE SECURITY DEPOSIT" BY
"INSURANCE SURETY BOND"**

- a) The Insurance Surety Bond shall be from an Insurer as per guidelines issued by Insurance Regulatory and Development Authority of India (IRDAI).
- b) The Company shall be the Creditor, the Contractor shall be the Principal debtor and the Insurance company/ Insurer shall be the Surety in respect of the Insurance Surety Bond to be issued by the Insurer.
- c) The Insurance Surety Bond should be on Non-Judicial stamp paper/e-stamp paper of appropriate value as per Stamp Act prevailing in the state(s) where the Insurance Surety Bond is submitted or is to be acted upon or the rate prevailing in State where the Insurance Surety Bond is executed, whichever is higher. The Stamp Paper/e-stamp paper shall be purchased in the name of Contractor / Insurer issuing the Insurance Surety Bond.
- d) The expiry date and values should be arrived at in accordance with instructions provided in the "Forwarding Letter" of the Tender.
- e) The Insurance Surety Bond by Contractors will be given from Insurer as specified in the Tender.
- f) A letter from the issuing insurer of the requisite Insurance Surety Bond confirming that the said Insurance Surety Bond / all future communication relating to the Insurance Surety Bond shall be forwarded to the Purchaser at its address as mentioned at "ITB".
- g) Contractor must indicate the full postal address of the Insurer along with the Insurer's E-mail / Phone from where the Insurance Surety Bond has been issued.
- h) Contractor must indicate Name, Address, Contact number and official Email ID of the Controlling Office of the Surety Issuing Branch or any web portal link, from whom / where the Surety Bond can be got confirmed by the Company.

Proforma – R

Format for Sustainable Development (SD) and Environment, Social & Governance (ESG) Questionnaire.

Explanatory Note-ESG Questionnaire for Suppliers & Vendors

1 Emissions Reporting

What are Greenhouse Gas (GHG) Emissions?

Greenhouse gas (GHG) emissions refer to gases that trap heat in the Earth's atmosphere, contributing to global warming and climate change. These include carbon dioxide (CO₂), methane (CH₄), and nitrous oxide (N₂O), among others. GHG emissions are generated from various sources, such as burning fossil fuels, industrial activities, and deforestation.

What are Scope 1 and Scope 2 Emissions?

- **Scope 1 Emissions:** Direct emissions from sources owned or controlled by your company (e.g., fuel combustion in company-owned vehicles, boilers, and generators).
- **Scope 2 Emissions:** Indirect emissions from purchased electricity, steam, heating, and cooling consumed by your company. These emissions occur at

the power generation source but are attributed to your business due to electricity consumption.

How to Calculate GHG Emissions?

Emissions are typically calculated using the following formula:

GHG Emissions (kg CO₂e) = Consumption data x Emission Factor

- **Consumption Data:** Fuel consumption (liters), electricity use (kWh), etc.
- **Emission Factor:** Standard values published by organizations like the IPCC

Examples:

1. **Fuel Consumption-Based Calculation (Scope 1):**

- o If you use 1,000 liters of diesel in company vehicles, and the emission factor for diesel is 2.68 kg CO₂e per liter, your emissions are: 1,000x2.68=2,680 kg CO₂e

2. **Electricity Consumption-Based Calculation (Scope 2):**

- o If your facility consumes 5,000 kWh of electricity, and the emission factor for your electricity provider is 0.4 kg CO₂e per kWh, your emissions are: 5,000x0.4=2,000 kg CO₂e

Sample Responses:

<u>Question</u>	<u>Sample Response</u>
What was the GHG emission for FY24	<p>a) Scope 1: 10,500 kg CO₂e</p> <p>b) Scope 2: 8,200 kg CO₂e</p>
What was the GHG emission per unit revenue for FY24?	<p>a) Scope 1: 2.5 kg CO₂e per INR 1,000 revenue</p> <p>b) Scope 2: 1.8 kg CO₂e per INR 1,000 revenue</p>

<u>Questionnaire for vendors and suppliers</u>			Response
1. Emissions	What was the GHG emission for the last financial year ?	a) Scope 1 GHG emissions (kg CO ₂ e)	
		b) Scope 2 GHG emissions (kg CO ₂ e)	
	What was the GHG emission per unit	a) Scope 1 GHG emissions (kg CO ₂ e)	

	of revenue for the last financial year?	b) Scope 2 GHG emissions (kg CO ₂ e)	
2. Decarbonization strategy & targets	Do you have a Net Zero target? If yes, please state the year		
	Do you have an emissions reduction target? If yes, are the targets absolute emissions based, or intensity based?		
	Please state the target for reduction in next financial year	a) Scope 1 GHG emissions/emissions intensity	
		b) Scope 2 GHG emissions/emissions intensity	
Please provide information on a few decarbonization initiatives undertaken (describe the initiatives and their respective impact)			
3. Waste & Water Mgt.	Do you have any initiatives for waste management including solid wastes, liquid wastes and hazardous waste?		
	Do you have any initiatives for water management including monitoring of water consumption and withdrawals, and if applicable, treatment of wastewater?		
4. Disclosures	Are your current emissions verified? If yes, please name the assuring body		
	Are your emissions targets validated (eg: SbTi)? If yes, please name the methodology		
	Are you rated by any of the ESG rating agencies? If yes, please specify the agency and rating		

Suppliers and vendors may refer to the explanatory note for any questions or clarifications pertaining to any of the questions above.

2 Decarbonization Strategy & Targets

Net Zero and Emission Reduction Targets

- **Net Zero Target:** A Net Zero target refers to a commitment to reducing emissions to as close to zero as possible, with residual emissions offset by carbon capture or other means. OIL would like to know if your organization has set any targets of becoming net zero, and if so, what is the targeted year.

- **There are 2 types of defining the target:**

Absolute Reduction: A fixed percentage decrease in emissions over a period (e.g., 10% reduction by 2030).

Intensity-Based Reduction: Reduction in emissions per unit of production or revenue (e.g., 15% reduction per product by 2025).

Sample Responses:

Question	Sample Response
Do you have a Net Zero target? If yes, please state the year	Yes, by 2040
Do you have an emissions reduction target? If yes, are the targets absolute emissions based, or intensity based?	Yes, we aim for an absolute 40% reduction by 2030, and 100% by 2040
Please state the target for reduction in FY24.	a) Scope 1: 10% absolute reduction b) Scope 2: 10% absolute reduction
Please provide information on a few initiatives undertaken (describe the initiatives)	Afforestation EV inclusion Electrification of gas-based equipment Renewable energy setup
How much of the reduction targets have been achieved till date? (eg: more than 80% achieved, less than 20% etc)	~5 % reduction has been achieved

3. Waste & Water

Management Waste

Management Initiatives

In order to answer the question regarding waste management initiatives, vendors and suppliers may mention few of the initiatives that their organizations have undertaken that may include (but are not limited to):

- Recycling and reusing materials
- Proper disposal of hazardous waste
- Reducing landfill waste through composting or waste-to-energy programs

Water Conservation Initiatives

Similar to the waste management initiatives, in order to answer the question regarding water conversation initiatives, vendors and suppliers may mention few of the initiatives that their organizations have undertaken that may include (but are not limited to):

- Monitoring water consumption with meters
- Installing water-efficient fixtures
- Treating wastewater before discharge

Sample Responses:

Question

sample Response

Do you have any initiatives for waste management including solid wastes, liquid wastes and hazardous waste?

Yes, we recycle 60% of our production waste and have SOPs in place for proper dispose of hazardous materials.

Do you have any initiatives for water management including monitoring of water consumption and withdrawals, and if applicable, treatment of wastewater?

Yes, we have meters to monitor water withdrawals and have a wastewater treatment process.

4. Disclosures

Verification & Validation of Emissions Data

- **Current emissions verification:** There are certain third-party agencies that verify an organization's emissions. These organizations provide independent assessments to ensure transparency and accuracy in emissions reporting. Verification by such agencies enhances credibility and aligns businesses with best sustainability practices. In case your organization's current emissions are validated by such a third-party agency, please specify the name of such an agency.
- **Emissions target validation:** If you have a target of reducing your carbon footprint, certain organizations validate the roadmap of achieving a lower carbon footprint. In case you have prepared a roadmap and submitted it to SBTi or Transition Pathways Initiatives, and have received certificates that have validated the targets, please specify the agency that has validated your targets.
- **ESG Ratings:** Certain agencies assess organizations based on their disclosures, monitoring capabilities, and control measures, among other factors. Some of these agencies, such as CDP and S&P, are globally recognized for their ratings. If your organization has received a rating from any of these agencies, please specify the agency's name and your assigned rating.

Sample Responses:

Question

Sample Response

Are your current emissions verified? If yes, please name the assuring body

Yes, verified by XYZ agency

Are your emissions targets validated (eg: SbTi)? If yes, please name the methodology

Yes, validated by SBTi

Are you rated by any of the ESG rating agencies? If yes, please specify the agency and rating Yes, CDP rating: D.

Proforma – S

**~~PROFORMA FOR UNDERTAKING FROM THIRD PARTY DOCUMENT VERIFICATION
INSPECTION AGENCY
(To be submitted on official letter head)~~**

~~TO,~~

~~GM MATERIALS
MATERIALS DEPARTMENT
P.O. DULIAJAN, PIN-786602
DIST. DIBRUGARH, ASSAM, INDIA~~

~~Sir,~~

~~_____ SUB : OIL's tender No.~~

~~M/s _____ having registered office at _____ intend to participate in the above referred tender of OIL INDIA LIMITED.~~

~~The tender conditions stipulated that the bidder shall submit documents pertaining to Bid Evaluation Criteria / Bid Rejection Criteria (BEC / BRC), duly verified and certified by designated independent Third Party Document Verification Inspection Agency.~~

~~In this regard, we hereby certify that copies of documents pertaining to Bid Evaluation Criteria / Bid Rejection Criteria (BEC / BRC), submitted to us by the bidder. M/s _____ have been verified and certified by us with originals and found to be genuine and authentic. We have signed and stamped on the copies of all the verified and certified documents having _____ nos. pages.~~

~~Note: In the event of any requirement, OIL reserves the right to ask the inspection agencies to verify the documents with source, if required at no extra cost to OIL.~~

~~_____ Thanking you,~~

Authorised Person's Signature: _____

Name: _____
