

REPLACEMENT OF 900 MHZ UHF RADIO FOR A.P. COMMUNICATION

Annexure-A

CONTENTS

<u>SECTION</u>	<u>SUBJECT</u>	<u>NO. OF SHEETS</u>
A	SCOPE OF ENQUIRY	1
B-1	PROJECT INFORMATION - GENERAL	1
B-2	PROJECT INFORMATION - EXISTING RADIO NETWORK DETAILS	2
C	SCOPE OF SUPPLY	2
D-1	TECHNICAL SPECIFICATIONS	8
D-2	SPECIAL CONDITIONS OF THE CONTRACT	5
E-1	SCHEDULE OF PRICES	1
E-2	SCHEDULE OF DEVIATIONS FROM TECHNICAL SPECIFICATIONS	1
E-3	BIDDER'S EXPERIENCE	1
F	BID EVALUATION/ REJECTION CRITERIA	3

REPLACEMENT OF 900 MHZ UHF RADIO FOR A.P. COMMUNICATION

SECTION A

SH 1 OF 1

1.0 SCOPE OF ENQUIRY

- 1.1 This procurement specification covers design engineering, packing, supply, transportation from place of manufacture to site, complete installation, testing at site after installation, integration with the existing system, startup, commissioning and performance testing of the 3 hop Radio communication(ISM band)system for voice, data and fax facilities on Turn Key basis.
- 1.2 The tender document includes the detailed information of the project (Section B), Scope of Supply & Technical Specifications (Section C and D), other requisite formats (Section E) and Bid Rejection Criteria / Bid Evaluation Criteria (BEC / BRC) (Section F).
- 1.3 Bidders must take cognisance of all the sections of this document. Similarly bidders must submit their price bids and Summary of Prices as per the format given vide Section E1.

REPLACEMENT OF 900 MHZ UHF RADIO FOR A.P. COMMUNICATION

SECTION B-1

SH 1 OF 1

1.0 PROJECT INFORMATION - GENERAL

- 1.1 Owner/ Purchaser : OIL INDIA LIMITED
- 1.2 Project Title : Replacement of A.P.
(Arunachal Pradesh)
Radio Communication System
- 1.3 Location : DULIAJAN & DIGBOI in Assam
and KHARSANG & MANABHUM in
Arunachal Pradesh
- 1.4 Rainfall
a) Maximum : 480 mm (in July)
b) Minimum : 27 mm (in November)
- It rains generally throughout the year.
- 1.5 Wind Velocity
a) Maximum Wind speed : 180 Km/hr
a) Prevailing wind : From east
Conditions (direction)
- 1.6 Environment : Humid

REPLACEMENT OF 900 MHZ UHF RADIO FOR A.P. COMMUNICATION

SECTION B-2

SH 1 OF 2

1.0 PROJECT INFORMATION - EXISTING RADIO NETWORK DETAILS

The existing radio network for AP communication is providing backbone for the voice communication requirement of OIL INDIA LIMITED at its Field Head Quarter DULIAJAN with other operational areas located at DIGBOI, KHARSANG and MANABHUM through an EPABX network. EPABXs of DIGBOI, KHARSANG and MANABHUM are connected to Main Exchange at Duliajan through E&M Trunk Circuits. The drawing of the existing network is shown in below.

2.0 Present Traffic Plan and other details :

2.1 Site Name : Naharkotiya ↔ Digboi ↔ Kharsang ↔ Manabhum

2.2 Present Traffic Plan :

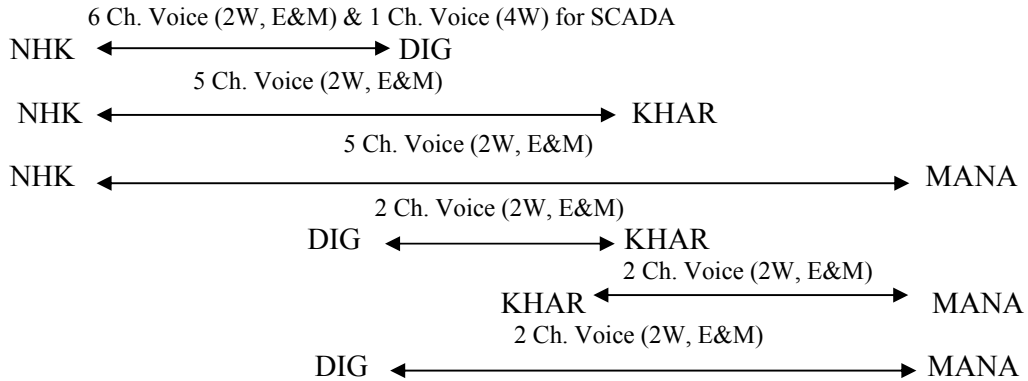

2.3 Site details for Microwave link in Assam and Arunachal Pradesh

Sl. No.	Name of the station	Latitude	Longitude	HASL (Mtr)	Tower Height (Mtr)	Distance (LOS) between (Km)
1	Nahorkatia	27°21'02''	95°19'09''	119	100	Nah-Dig : 32.9
2	Digboi	27°23'30''	95°39'02''	168	100	Dig-Khar : 37.8
3	Kharsang	27°24'02''	96°02'05''	214	100	Khar-Man : 19.45
4	Manabhum	27°31'46''	96°10'03''	244	30	-

REPLACEMENT OF 900 MHZ UHF RADIO FOR A.P. COMMUNICATION

SECTION B-2

SH 2 OF 2

- 3.0 Backbone Communication** : Presently Harris LR900 UHF radio equipment(900+/-60 MHz band) is working in above link using antenna size of 4m/2m. Existing 100m Tower at Naharkotiya, Digboi and Kharsang and 30m Tower at Manabhum will be used for new radio communication system.
- 4.0 Other radio frequencies in use** : There is already 2 pairs of 2.4 GHz license free radio in operation between Naharkotiya and Digboi.
- 5.0 PABX connection** : Presently E1 (2 MB) line is interfaced with Primary Multiplexer (75 ohm, Coaxial, Unbalanced). From 2W TCM card of Primary Multiplexer, E, M, T, R lines are connected to PABX for voice communication.
- 6.0 SCADA service** : SCADA data from Digboi is fed to main SCADA system at Naharkotiya using 4W TCM card of Primary Multiplexer.

REPLACEMENT OF 900 MHZ UHF RADIO FOR A.P. COMMUNICATION

SECTION C

SH 1 OF 2

SCOPE OF SUPPLY,WORKS AND SERVICES

1.0 SYSTEM TO BE OFFERED

1.1 This procurement specification covers design engineering, packing, supply, transportation from place of manufacture to site, complete installation, testing at site after installation, integration with the existing system, commissioning and performance testing of the 3 hop Radio communication system for voice, data, Fax Internet, SAP, E-mail facilities on turn key basis.

1.2 PROPOSED COMMUNICATION NETWORK

<u>S/N</u>	<u>Details</u>
	20 MBPS Radio Equipment
	5.8 GHz Licence Free Band
1	Including Antenna, Reflector, Power Supply, Antenna through line surge suppressor etc. (SECTION-D1 : CLAUSE 1)
	E1 MUX to transport upto 4E1 TDM traffic across an
2	Ethernet link (SECTION-D1 : CLAUSE 2)
	Dual Redundant Online UPS with SMF Battery for 48 hours
3	backup (SECTION-D1 : CLAUSE 3)
	Transient Voltage Surge Suppressor
4	(SECTION-D1 : CLAUSE 4)
	Earth pit
5	(SECTION-D1 : CLAUSE 5)
	Installation, Testing and Commissioning of all the systems and sub-systems supplied as mentioned in above including smooth change-over as per details given in special conditions of the contract
6	(SECTION-D2 : CLAUSE 1.9)
	Training
7	(SECTION-D2 : CLAUSE 1.13)

REPLACEMENT OF 900 MHZ UHF RADIO FOR A.P. COMMUNICATION

SECTION C

SH 2 OF 2

S/N	Details
8	Comprehensive AMC (including spares) for 02 years after expiry of warranty and extendable up to 10 years as per details given in special conditions of the contract (SECTION-D2 : : CLAUSE 1.11)
9	Vital spares to be maintained at site
10	Any other item not specified above but required to meet the technical specifications for successful installation and commissioning of the entire system
11	Any other works/service not specified above but required for successful completion of the entire project

REPLACEMENT OF 900 MHZ UHF RADIO FOR A.P. COMMUNICATION

SECTION D-1

SH 1 OF 8

1.0 TECHNICAL SPECIFICATIONS OF RADIO EQUIPMENT

(Bidder to write complied/not-complied against each clause in the compliance statement)

- 1.1 The offered radio capacity shall be 20 MBPS of Ethernet traffic and shall work in 5.825 GHz to 5.875 GHz license free ISM band only with maximum EIRP of 4W.
- 1.2 There should be minimum Fade Margin of 10 db in each hop.
- 1.3 System should support connection of IP based Telephone exchange for Voice, Data and Fax communication.
- 1.4 System should support E1 Mux for conversion of IP traffic to TDM circuits to connect Primary Mux.
- 1.5 The system should be based on state of art QoS IEEE 802.16 or Equivalent PHY and MAC layer.
- 1.6 The system should have the capability to have centralized (One point of management) full control of the system configuration, monitoring of the system units using a GUI.
- 1.7 The EMS must support IN-BAND management of the Network Elements using SNMPV2.
- 1.8 The System Should support centralized bandwidth management and authentication system for high security and QoS.
- 1.9 The system should support remote maintenance of radio units.
- 1.10 The system should have the capabilities of upgrading the Software without interrupting the normal system service.
- 1.11 The system should allow enabling prioritization of VOIP and Video over data traffic.

REPLACEMENT OF 900 MHZ UHF RADIO FOR A.P. COMMUNICATION

SECTION D-1

SH 2 OF 8

- 1.12 The system should be capable of applying different qualities like offering different services types, latency, jitter and bandwidth control for each direction (uplink and downlink) independently.
- 1.13 The system should be scalable in terms of deployment - a system deployment may be small as one sector and one subscriber or as large as thousands of subscribers in a multi sector base station deployment.
- 1.14 Wireless system must be capable of easy and rapid deployment to avoid lengthy way-leave, access and legal agreements.
- 1.15 The system should have self-interference prevention with synchronization, between different Base stations and between co-locating sectors within a base station using GPS bases synchronization system.
- 1.16 The system should have built in targeted coverage capability (Ability to daisy chain the link) both in point to point and in Point to Multipoint system.
- 1.17 The system should enable fully automatic configuration including QoS, once they acquire an RF link to the base station.
- 1.18 The System signaling rate must be equal or more than 20Mbps over 20MHz channel.
- 1.19 The system must support extensive networking modes including switching, VLAN tagging and classifications etc.
- 1.20 The system must be equipped with surge suppressors to protect it from unavoidable lightning conditions.
- 1.21 The system must support high level of security mechanisms such as DES, AES, BRAID authentication etc for end-to-end connectivity to avoid any breaches due to Interference or hacking.

REPLACEMENT OF 900 MHZ UHF RADIO FOR A.P. COMMUNICATION

SECTION D-1

SH 3 OF 8

- 1.22 The system both in point to point and point to Multipoint mode must support high level of Interference mitigation techniques at MAC layer structure, low C/I and efficient error correction techniques.
- 1.23 Bidder shall submit **link engineering details** with all calculations along with the bid in respect of desired parameters of specifications.
- 1.24 The equipment shall be installed with additional **lightening protection** arrangement. Necessary earth pits to be installed at all sites.
- 1.25 All the sites have 230V AC supply. The equipment shall be supplied with **dual redundant online UPS** system with a **backup of 48 hrs** at all sites. The calculation for rating of battery to be provided. Technical specifications of the charger unit of the UPS to be provided to charge battery of such rating.
- 1.26 The UPS shall be **SNMP enabled** in order to monitor status of UPS remotely from Naharkotiya (Duliajan).
- 1.27 All 4 (four) sites shall be equipped with **16 port Data switches** for system integration.

Salient features

- Description : 5.8 GHz Licence Free Band
Operating Backhaul Module
- Signaling Rate : 20 Mbps
- Minimum Useful Throughput 10.0 Mbps
- Frequency range of band : 5.825 to 5.875 GHz
- Range LoS Up to 56 Kms
- Non-overlapping Channels 3
- Channel Width 20 MHz
- Channel Spacing every 2.5 MHz
- Carrier to Interference ratio(C/I) At least ~10dB @ 20 Mbps
- Receiver Sensitivity ≤ -86 dBm

REPLACEMENT OF 900 MHZ UHF RADIO FOR A.P. COMMUNICATION

SECTION D-1

SH 4 OF 8

- Antenna With reflector
- Equivalent Isotropic Radiated Power (EIRP) Maximum 4.0 W (Adjustable)
- Mean Time Between Failure (MTBF) at least 20 years
- Interface 10/100 Base T, half/full duplex
Rate auto negotiated
(802.3 compliant)
- Protocols Used IPV4, UDP, TCP, ICMP, Telnet, HTTP, FTP, SNMP
Network Management HTTP, TELNET, FTP, SNMP Version 2c

Power

- Power source 90-240 VAC, 50-60 Hz
- UPS Dual redundant UPS with 48 Hrs backup and SNMP monitoring
- Lightning Protection Transient Voltage Surge Suppressor , Antenna through line surge suppressor protection and earth pit

Other details

- Temperature -40° C to +55° C
- Wind Survival At least 180 km/hr
- Connection Distance between outdoor unit and primary network connection: up to 100 meters. Bandwidth and Authentication Manager Software on CD to be provided.

REPLACEMENT OF 900 MHZ UHF RADIO FOR A.P. COMMUNICATION

SECTION D-1

SH 5 OF 8

2.0 TECHNICAL SPECIFICATIONS OF E1 MUX EQUIPMENT

- 2.1 The offered E1 Mux equipment shall enable point to point multiplexing of E1 traffic across wired and wireless Ethernet devices. The unit shall provide seamless transport of E1 across an Ethernet link.
- 2.2 E1 Mux shall support from one to four E1's per link.
- 2.3 The E1 Mux shall allow multiplexing of LAN traffic with the E1 payload.
- 2.4 Because of the potential for changing conditions that could affect wireless network throughput, the E1 Mux shall provide the capability for recovering from data loss, without propagating the errors to following frames.
- 2.5 The E1 Mux shall work with Nokia or Bayly or Indchem make existing Primary mux. The Primary mux will carry voice, fax and telemetry data.

Salient features of E1 Mux

Network Interface

Type - 10/100 Base T; Auto-negotiation
Connector - RJ-45

Payload: IPv4 tunneling.

E1 Interface

Connector - RJ-45
Line Coding - HDB3I, B8ZS
Framing - Transparent
Number of TDM ports - 1, 2, 3, or 4
Jitter and Wander tolerances - ITU-T G.824
Standards - ITU-T Rec. G.703, G.704, G.706, G.732, G.823

Management

Protocol - HTTP - Telnet - CLI
Interface - 10/100 Base T, CONSOLE port RJ-45 to Serial
Upgrade capabilities

General

Protection - Lightning and power protection on every port
Operating Temperatures - 0 to +50 degrees Celsius

REPLACEMENT OF 900 MHZ UHF RADIO FOR A.P. COMMUNICATION

SECTION D-1

SH 6 OF 8

3.0 TECHNICAL SPECIFICATIONS OF DUAL REDUNDANT UNINTERRUPTED POWER SUPPLY (UPS) FOR 48 HRS. BACKUP

- 3.1 **TOPOLOGY:** DOUBLE-CONVERSION IGBT BASED TRUE-ONLINE UPS SYSTEM
- 3.2 **INPUT VOLTAGE RANGE :**180-250 VAC at 46-54 Hz (1-Phase)
- 3.3 **OUTPUT :** UPS Capacity : 3 KVA
VOLTAGE : 230VAC
O/P Voltage Regulation : +/- .8%
Line Regulation : ≤ 2%
Frequency (Free Running) : 50 HZ ± 0.2 HZ
Efficiency : ≥ 91.9%
TRANSFER TIME : NORMAL <->BATTERY: 0-mili second
- 3.4 **BYPASS :** Automatic
- 3.5 **MONITORING** Onsite: VIA RS232 port
 Remote: Through **SNMP**
- 3.6 **PROTECTION :** Over Voltage Cut Off Device, MCB, Over Voltage & Under Voltage Advanced Electronic Protection for device safety backed with MCBs/ MCCBs/ Fast Acting Fuse. High Speed pulse blanking. Electronic over voltage / under voltage. Transient Voltage Surge should be suppressed within 0.5 nsec with RFI/EMI attenuation 40dB
- 3.7 **NOISE LEVEL** : <45 dB at 1 meter
- 3.8 **AMBIENT TEMPERATURE :** 0 Degree~ 40 Degree Centigrade
- 3.9 **INTERNATIONAL CERTIFICATIONS FOR SAFETY ETC.**

EMI (ELECTRO MAGNETIC INTERFERANCE)

- A) Limitation of emission of input harmonic currents EN61000-3-2
 - B) Limitation of voltage changes, Voltage fluctuations and flicker input harmonic currents EN61000-3-3
 - C) Conducted Emission EN50091-2, Level Class B
 - D) Radiated Emission EN50091-2, Level Class B
- EMS**
- ESD Immunity IEC61000-4-2, Level 4
 - RS Immunity IEC61000-4-3, Level 3
 - EFTB Immunity IEC61000-4-4, Level 4

REPLACEMENT OF 900 MHZ UHF RADIO FOR A.P. COMMUNICATION

SECTION D-1

SH 7 OF 8

Surge Immunity	IEC61000-4-5, Level 4
Protection	IP 20 (Static State)
Environmental Compliance	ISO 14001

3.10 **Battery** : SMF Batteries with Battery Rack & interlinking cables. Battery capacity shall meet 48 Hrs. backup for supplied wireless equipment along with associated equipment.

3.11 **DUAL REDUNDANCY** : There shall be 2 identical UPS and a changeover switch for automatic hitless changeover of power in case of failure of on-duty UPS.

3.13 Manufacturer of UPS should be **ISO 9001:2000** certified with service center facility in North East to attend any fault on site within 24 Hrs.

4.0 TECHNICAL SPECIFICATIONS OF TRANSIENT VOLTAGE SURGE SUPPRESSOR (TVSS)

Transient Voltage Surge Suppressor (TVSS) shall be connected AC input line.

Surge Current Capacity : 25KA

Connection Type : 1 Phase Parallel

Operating Voltage Range : 15%

Fault Current Rating(AIC): 14 KAIC

Operating Frequency Range: 47 to 63 KHz

EMI/RFI Attenuation : 40 dB typical

Response Time : <0.5 nanosecond

5.0 EARTHING:

The earthing design for A.P. Communication Radio equipment at each location shall be as mentioned below:

No. of pits: 2 nos per site.

REPLACEMENT OF 900 MHZ UHF RADIO FOR A.P. COMMUNICATION

SECTION D-1

SH 8 OF 8

Type of Electrode: 25x3 mm copper strip of length 2.3 mtrs. At the bottom (minimum depth 2 mtr.) fitted with 600x600x3 mm copper plate.

Distance between pits: 3 mtrs.

Pit dimension: WxBxD= 700x700x2000mm

Pit wall with Cover : Top half of Earth pit to be protected by brick wall. Dimension of brick work shall be 700X700X1000 mm.(WxBxD). 300 mm of the Brick work will be over the ground level for easy identification. Prefabricated 500x500 metal cover with metal frame slot for fitting with the Earth pit brick work is to be installed to cover the pit.

Future treatment arrangement: 2.3 mtrs. Length 1.5" perforated B class medium quality GI water pipe placed in parallel to electrode strip in each pit.

Pit filling: 15 cm consecutive layers of salt and charcoal to be covered the 600mmx600mm copper plate fully from the bottom side of the pit. Rest by normal soil upto ground level.

Interconnection of pits: By 16 sq.mm multistrand single insulated copper cable. Extension upto internal ground bus bar of dimension 25x3 mm and 30 cm length by same nature of cable. The cable for interconnection of pits will be laid at a depth of 500 cm below the ground level and the trench will be back filled by normal soil only.

Connecting lugs: 16 sq. mm Copper lugs

Type of fastners: SS Nuts, bolts and washers for fitting of copper plate with copper strip, for interconnection of pits by copper lugs etc.

Earth resistance : Cumulative<= 0.5 ohms while measured from bus bar

Earth Distribution: From Earth pit to equipment rack bus bar by 16 sq. mm green insulated multistrand single core copper cable.

REPLACEMENT OF 900 MHZ UHF RADIO FOR A.P. COMMUNICATION

SECTION D-2

SH 1 OF 6

SPECIAL CONDITIONS OF THE CONTRACT

1.1 **Standards of the works :**

The works shall be in accordance with the contract. To the extent that the standard of the works has not been specified in the CONTRACT, the CONTRACTOR shall use good quality materials, techniques and standards and execute the contract with care, skill and diligence required in accordance with best practice.

1.2 **SPARES**

The CONTRACTOR shall maintain a supply of spares or replacement parts for a period of **10 (Ten) years** from the completion certificate date, such spares or replacement parts should be fully compatible with similar items previously supplied. The bidder has to submit a certificate from OEM confirming spares and technical support for at least 10 years.

1.3 **SOFTWARE**

Unless otherwise stated in the contract, the CONTRACTOR shall be responsible for providing in accordance with the contract all latest software and associated documentation necessary for the satisfactory operation of the equipment.

Any software upgrades in future shall not necessitate replacement of hardware supplied under this contract.

1.4 **QUALITY ASSURANCE**

The BIDDER will submit a detailed procedure for Quality Assurance alongwith his Bid. The Bid shall be considered incomplete in the absence of Quality Assurance procedure. The Quality Assurance procedure should indicate the organizational approach for Quality Control & Quality Assurance of the job.

1.5 **DOCUMENTATION**

CONTRACTOR shall furnish **5 (five) sets** each of Hard & Soft copies of the manuals for each equipment necessary to test, maintain and support the system including the software.

REPLACEMENT OF 900 MHZ UHF RADIO FOR A.P. COMMUNICATION

SECTION D-2

SH 2 OF 6

1.6 **TESTS**

The tests concerns all the equipment consisting the system including the equipment supplied by sub-contractors.

1.7 **FIELD ACCEPTANCE TEST**

Once the system is installed and operating, it shall be tested by the Vendor and witnessed by ENGINEER. The test shall be carried out as per the detailed test procedure supplied by Vendor and approved by the ENGINEER. Once the tests have been successfully performed, the temporary acceptance of the system will be given. Only then the system will be ready for "**Test Run**".

1.8 **TEST RUN**

1.8.1 This test aims at keeping the complete system in operation for a **period of 10 days continuously**. In case of failure, the tests will be re-started till the system operates without failure for 10 days continuously. ENGINEER shall have the right to reject the complete system or part thereof in the event of the acceptance tests failing in two attempts. The "Test Run" shall be carried out after the commissioning of complete system.

1.8.2 Various observations and test results obtained during the various tests shall be documented and produced in the form of a report by the Vendor.

1.8.3 If malfunctions or failure of a unit or sub-system repeat, the test shall be terminated and vendor shall replace the necessary components and assemblies to correct the deficiencies. Thereafter, the test shall commence all over again from the start as mentioned above. If after this one replacement, the unit or sub-system still fails to meet the specifications, the Vendor shall replace the complete unit or sub-system with the one that meets the requirements, and restart the test all over again.

All cost for repair/replacement of defective component/system shall be debitable to vendor's account.

REPLACEMENT OF 900 MHZ UHF RADIO FOR A.P. COMMUNICATION

SECTION D-2

SH 3 OF 6

1.9 **INSTALLATION AND COMMISSIONING**

1.9.1 The whole project is required to be completed **on Turn-Key basis**. Accordingly, Bidder is understood to have assessed and quoted for all the items required for successful completion of the Project. It will be the responsibility of the Contractor to provide free of charge such items, not quoted in the bid, but otherwise required to have been provided at the time of installation for completion and successful commissioning of the project.

1.9.2 The Vendor shall offer the services of an installation Team which would install and commission the entire system

1.9.3 Vendor shall bring all installation aids and test equipment in order to carry out the job successfully. A list of the same is to be submitted to the ENGINEER for the review.

1.10 **WARRANTY**

1.10.1 The CONTRACTOR shall warrant that all equipment are manufactured, with highest quality of materials. The equipment supplied and installed, software, documentation and workmanship are of the highest grade and consistent with the established and general standards for the application area and is in full conformity with the specifications given in the CONTRACT document. If any part or component or sub-system is found to be defective, the same shall be replaced free of all costs to the COMPANY. The decision of the COMPANY or ENGINEER in deciding defective component or part or sub-system shall be final.

1.10.2 The system shall be **guaranteed** to give the specified performance for a period of **twenty four months** from the date of issue of COMPLETION CERTIFICATE by the COMPANY. In case any part or component or sub-system or equipment (Hardware & Software) is found to be defective and is replaced/ modified in accordance with clause 1.10.1 above, the item shall be guaranteed for a further period of twenty four months. **All maintenance work, components, spare parts etc. during the warranty period shall be at the cost of CONTRACTOR.**

REPLACEMENT OF 900 MHZ UHF RADIO FOR A.P. COMMUNICATION

SECTION D-2

4 OF 6

1.10.3 Supplier shall post a **service engineer at Duliajan** during warranty period. The service engineer so posted shall be qualified and fully conversant with the operation and maintenance aspect of the complete system. **Service engineer shall rectify any fault within 24 hours of reporting.** Failure to rectify the fault within the stipulated period, will attract penalty as mentioned in penalty clause 1.12

1.11 **ANNUAL MAINTENANCE CONTRACT**

1.11.1 The Communication system being supplied, installed and commissioned is required to be maintained for Ten (10) years after warranty period. The system is required to be fully operational round the clock. The bidder must quote for providing maintenance service through **Comprehensive Annual Maintenance Contract** for a period of two (2) years which shall be extendable upto a period of Ten years taking following points into consideration:

1.11.2 Supplier shall post a **Service Engineer at Duliajan** for the entire period including warranty period. The service engineer so posted shall be qualified and fully conversant with the operation and maintenance aspect of the complete system. **Service engineer shall rectify any fault within 24 hours of reporting.** Failure to rectify the fault within the stipulated period, will attract penalty as mentioned in penalty clause 1.12

1.11.3 The service engineer shall check the health of the system regularly. Any defect or breakdown observed or reported by OIL shall be attended immediately. Periodic preventive maintenance shall be done by the service engineer as per the maintenance schedule recommended by the manufacturer and report to be submitted to OIL.

1.11.4 Supplier shall maintain minimum vital spares at site (Duliajan) to restore the system immediately in case of breakdown during warranty and AMC period. List of vital spares to be maintained at site should be provided.

REPLACEMENT OF 900 MHZ UHF RADIO FOR A.P. COMMUNICATION

SECTION D-2

5 OF 6

- 1.11.5 The charge quoted for **Annual Maintenance Contract (AMC)** shall be fixed and firm for following items:

S/N	Description	Units	Qty.
1	20 Mbps Radio Equipment including antenna, reflector, power supply, through line surge suppressor etc	Sets	6
2	E1 Mux to transport upto 4 E1 traffic across an Ethernet link	NOS.	6
3	Dual redundant online UPS with SMF battery for 48 hrs backup	SETS	4
4	Transient voltage surge suppressor	NOS.	4

- 1.11.6 **The AMC charge will be inclusive of all spares required for maintenance.**

- 1.11.7 The payment for AMC shall be released quarterly after providing satisfactory service.

- 1.11.8 **The quoted 2 years AMC price for items mentioned in Clause 1.11.5 shall be included for evaluation of L1 bidder.**

- 1.12 **Penalty clause:**

- 1.12.1 In case you fail to repair or replace a defective part(s) under warranty services mentioned in warranty clause, within 24 hours, from the time of reporting the breakdown, a penalty @ Rs. 1000/- per day, will be levied. If for any reason, the bidder fails to provide services within seven successive days from the date of reporting, the period of warranty or AMC will be extended by that number(s) of days, at no extra cost, in addition to the above penalty, subject to a maximum of 15% of the total order value.

- 1.12.2 The penalty amount will be realised by invoking the Performance Bank guarantee for the amount or from any payment due to successful bidder as deemed fit.

- 1.12.3 The defective parts under warranty should be first repaired / replaced and thereafter the defective items can be taken out of OIL's premises. Failure to repair or replace a defective part(s) under warranty within the stipulated period will attract penalty as mentioned in clause 1.12.1.

REPLACEMENT OF 900 MHZ UHF RADIO FOR A.P. COMMUNICATION

SECTION D-2

6 OF 6

1.13 **DELIVERY SCHEDULE**

Time is the essence of this project. The project is requires to be completed **within 3 (Three) months** from date of issue of Purchase Order / Letter of Intent.

1.14 **TRAINING**

Basic training to Company's personnel to be provided by the contractor on Installation, Operation and Maintenance of the system supplied at OEM's manufacturing premises. Bidder should indicate the venue and duration for such training.

1.15 **BIDDER TO OBTAIN OWN INFORMATION**

1.15.1 In their own interest, BIDDERS are advised to visit the site, prior to submission of BIDS to acquaint themselves with the site conditions, availability of space at various locations of existing Tower and proposed installations, availability of facilities etc.

1.15.2 During such visit, BIDDERS shall interact with the user department and obtain information regarding existing equipment and exact requirement of proposed system.

1.15.3 After the visit, it will be understood that the BIDDERS have known all the requirements of this Project which will facilitate them to quote for all the items.

REPLACEMENT OF 900 MHZ UHF RADIO FOR A.P. COMMUNICATION

SECTION E-1

SH 1 OF 1

1.0 SCHEDULE OF PRICES

All the quoted prices shall be firm till the completion of said works.

SL NO	PARTICULARS	QTY	UNIT	UNIT PRICE		TOTAL PRICE
				(In figure)	(In words)	
1	20 MBPS RADIO EQUIPMENT 5.8 GHZ LICENCE FREE BAND INCLUDING ANTENNA, REFLECTOR, POWER SUPPLY, THROUGH LINE SURGE SUPPRESSOR ETC	10	SETS			
2	20 MBPS RADIO EQUIPMENT 5.8 GHZ LICENCE FREE BAND FOR SPARES	5	NOS.			
3	E1 MUX TO TRANSPORT UPTO 4 E1 TRAFFIC ACROSS AN ETHERNET LINK	8	NOS.			
4	DUAL REDUNDANT ONLINE UPS WITH SMF BATTERY FOR 48 HRS BACKUP	4	SETS			
5	TRANSIENT VOLTAGE SURGE SUPPRESSOR	8	NOS.			
6	EARTH PIT	8	NOS.			
7	INSTALLATION, TESTING AND COMMISSIONING OF ALL ITEMS TO MAKE THE ENTIRE NETWORK FULLY OPERATIONAL	1	LOT			
8	TRAINING	4	MAN WEEK			
9	COMPREHENSIVE ANNUAL MAINTENANCE CHARGES (AMC) FOR 2 YEARS (EXTENDABLE UPTO 10 YEARS) AFTER EXPIRY OF WARRANTY FOR THE ITEMS LISTED IN CLAUSE 1.11.5	2	YEARS			
10	ANY OTHER ITEM NOT SPECIFIED ABOVE BUT REQUIRED TO MEET THE TECHNICAL SPECIFICATIONS FOR SUCCESSFUL INSTALLATION AND COMMISSIONING OF THE ENTIRE SYSTEM	AS REQ UI- RED				
11	APPLICABLE TAXES					
TOTAL PRICE						

REPLACEMENT OF 900 MHZ UHF RADIO FOR A.P. COMMUNICATION

SECTION E-2

SH 1 OF 1

1.0 SCHEDULE OF DEVIATIONS FROM TECHNICAL SPECIFICATION

All the deviations from the technical specifications shall be filled-in by the BIDDER clause by clause in this schedule.

<u>SECTION</u>	<u>SPECIFICATION NO.</u>	<u>CLAUSE NO.</u>	<u>DEVIATION</u>
----------------	--------------------------	-------------------	------------------

The BIDDER hereby certifies that the above mentioned are the only deviations from the client's Technical specifications for this enquiry. The BIDDER further confirms that in the event of any other data and information presented in the BIDDER'S proposal and accompanying documents including drawings, catalogues, etc., are at variance with the specific requirements laid out in the Client's technical specifications, then the latter shall govern and will be binding on the BIDDER for the quoted price.

SIGNATURE: -----

DESIGNATION: -----

NAME OF BIDDER: -----

SEAL OF BIDDER

DATE: -----

REPLACEMENT OF 900 MHZ UHF RADIO FOR A.P. COMMUNICATION

SECTION E-3

SH 1 OF 1

1.0 BIDDER'S EXPERIENCE

The BIDDER shall furnish here a list of similar jobs executed by him to whom a reference may be made in case OIL considers such a reference necessary.

SL NO	NAME AND DESCRIPTION OF WORK	VALUE OF WORK	PERIOD OF EXECUTION AND DATE	CLIENT	PERSONS TO WHOM REFERENCE MAY BE MADE

SIGNATURE: -----

DESIGNATION: -----

NAME OF BIDDER: -----

SEAL OF BIDDER

DATE: -----

REPLACEMENT OF 900 MHZ UHF RADIO FOR A.P. COMMUNICATION

SECTION F

SH 1 OF 3

BID REJECTION CRITERIA (BRC) / BID EVALUATION CRITERIA (BEC)

(I) BID REJECTION CRITERIA (BRC)

The bids must conform to the specifications and terms and conditions given in the enquiry. **Technical brochures** of the offered radio equipment to be submitted. Bids shall be rejected in case the equipment offered do not conform to the required parameters stipulated in the technical specifications. Notwithstanding the general conformity of the bids to the stipulated specifications and terms and conditions, the following requirements shall have to be particularly met by the bidders, without which the offer will be considered as non-responsive and rejected:

(A) TECHNICAL :

- 1.1 BIDDER has to be the **Original Equipment Manufacturer (OEM)** or certified authorised representative of the offered Radio equipment. In case the bidder is a certified authorized representative, authorization certificate from the OEM has to be submitted for the project.
- 1.2 BIDDER must be in wireless network business for a period of at least last **3 (Three) continuous years** preceding the Bid Closing Date. BIDDERS are required to produce documentary evidence for the same in the prescribed format as given in Section E-3.
- 1.3 Bidder has successfully supplied, installed and commissioned **at least 3 (Three) nos. of wireless radio link** during last three financial years i.e. this year and previous four consecutive financial years.
- 1.4 Bidder must have **supply and support base in North-East India and should have maintenance base within 60 KM of Duliajan, Assam.** In case the bidder is a certified authorized representative, the bidder has to submit a certificate from OEM confirming spares and technical support for at least 10 years.
- 1.5 BIDDER must submit documentary evidence in the form of copy of Purchase Orders and job completion certificates issued by the clients supporting the experience mentioned in Para 3 and 4 above.

REPLACEMENT OF 900 MHZ UHF RADIO FOR A.P. COMMUNICATION

SECTION F

SH 2 OF 3

- 1.6 Vendor has to quote **firm comprehensive AMC rates** as asked for in the SCHEDULE OF PRICES (E-1).
- 1.7 Wherever vendor is quoting **additional hardware devices** like E1 Mux, UPS, Transient Voltage Surge Suppressor, Ethernet Data switches etc, the complete details of the product offered, make, configuration and warranty certificate from the OEM has to be enclosed.
- 1.8 Incomplete information, non-submission of proofs, certificates, relevant brochures etc. shall be treated as non-compliance. If any information provided by bidder is found to be incorrect, the bid shall be rejected.
- 1.9 The bid shall be in accordance with the specification and shall be complete in all respects. The bidder shall clearly indicate in his offer the list of deviations on a separate sheet (refer section E-2) even though these may be mentioned somewhere else in the quotation.

(B) COMMERCIAL :

As given in **Annexure-II to Annexure-VI.**

(II) BID EVALUATION CRITERIA (BEC) :

The bids conforming to the specifications, terms and conditions stipulated in the enquiry and considered to be responsive after subjecting to the Bid Rejection Criteria will be considered for further evaluation as per the Bid Evaluation Criteria given below :

(C) TECHNICAL :

- 1.0 All materials as indicated in the indent should be offered. If any of the items not offered by the bidder, the offer will not be considered for evaluation.

(D) COMMERCIAL : Total FOR Destination value

- 1.0 Bid will be evaluated taking into consideration **Total FOR Destination Value for all the items numbered 1 to 11 in Schedule of Prices in Section E-1 (which includes among others Cost of Equipment, Installation, Commissioning and 2 year AMC charges) in the same Schedule of Prices, quoted by the bidder.**

REPLACEMENT OF 900 MHZ UHF RADIO FOR A.P. COMMUNICATION

SECTION F

SH 3 OF 3

2.0 Rest as given in **Annexure-II to Annexure-VI.**

NOTE : If any of the Clauses of the Bid Rejection Criteria / Bid Evaluation Criteria (BEC / BRC) contradict the Clauses of the tender elsewhere, those in the BEC / BRC shall prevail.

=====